

FA Pneumatic Hole Clamp

Model WKH



Gripper expands and pulls a workpiece in.

Clamps a workpiece by holding its holes, allowing for 5 faces accessible.

Light Weight, Smaller Footprint, and High Power

PAT.

Transfer • Assembly with Robots

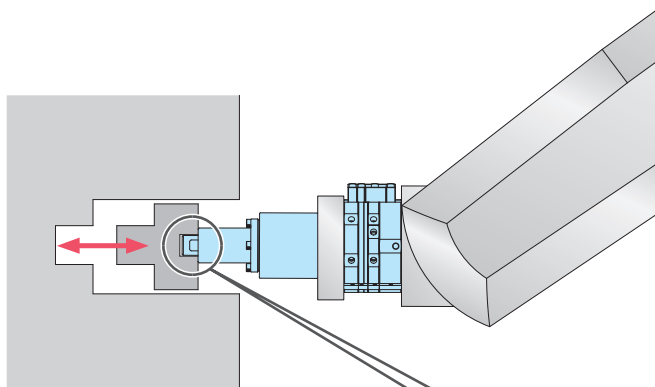

Transfer Equipment

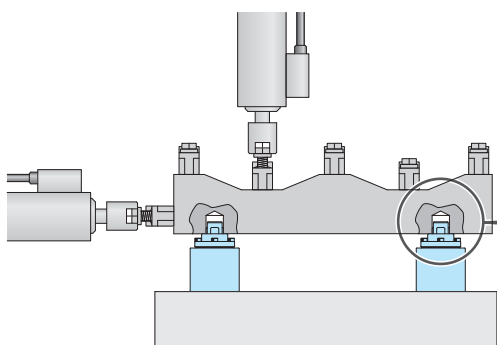
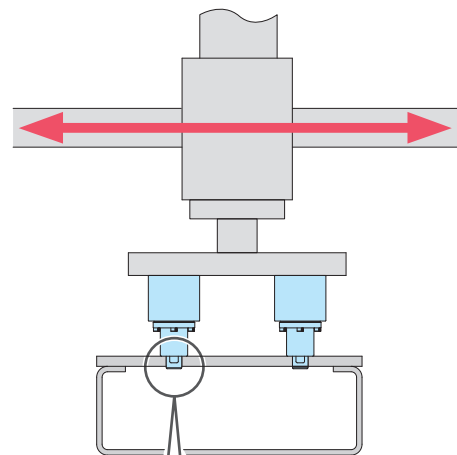

Assembling Equipment



Action Description

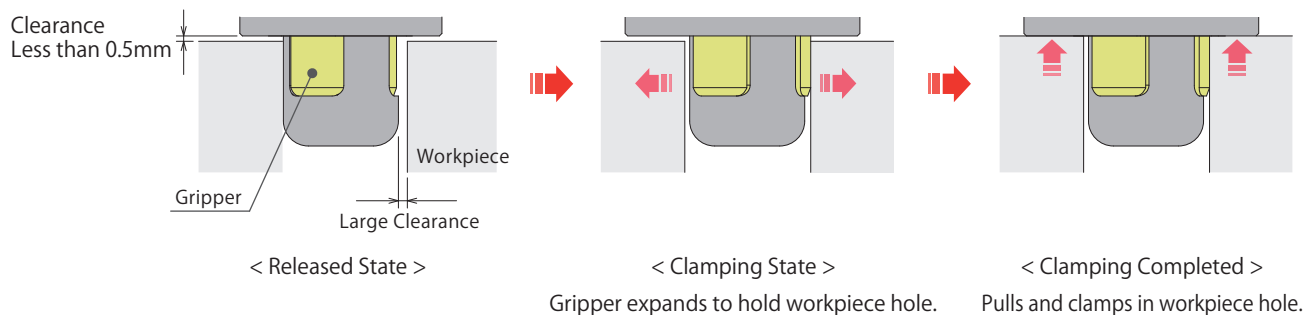

Locating + Clamp
Locating
Hand + Clamp
Support
Valve + Coupler
Cautions + Others

Advantages

Transfer • Light Weight

Compact and light weight loading/lifting hand part enables to downsize transfer equipment.

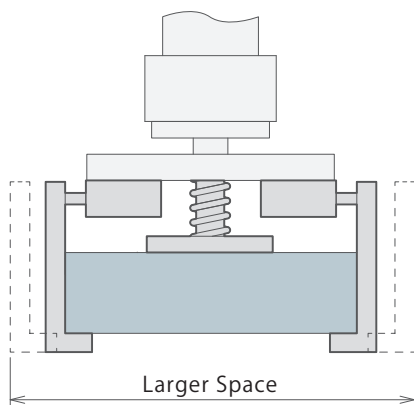

Loading/Lifting Hand with Parallel Hand/Linear Cylinder

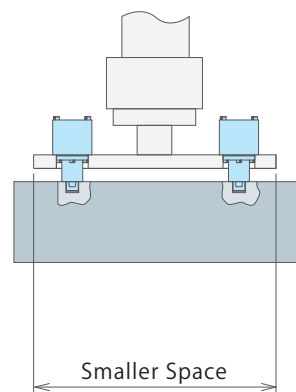

Compact Hole Clamp with Powerful Gripping Force

Pallet Gripper
WVA
Locating Pin Clamp
SWP
High-Power Pull Stud Clamp
WPT
JES
FA Pneumatic Hole Clamp
WKH
Lifting Hole Clamp
SWJ
Ball Lock Cylinder
WKA
Pneumatic Robotic Hands
WPW-C
WPS-C
WPA
WPH
WPP
WPQ
Auto Switch Proximity Switch
JEP
High-Power Pneumatic Hole Clamp
SWE
High-Power Pneumatic Swing Clamp
WHE
High-Power Pneumatic Link Clamp
WCE
Pneumatic Hole Clamp
SWA
Pneumatic Swing Clamp
WHA
Double Piston Pneumatic Swing Clamp
WHD
Pneumatic Link Clamp
WCA
Air Flow Control Valve
BZW
Manifold Block
WHZ-MD

No Interference

Able to access 5 faces of a workpiece and improves work efficiency.

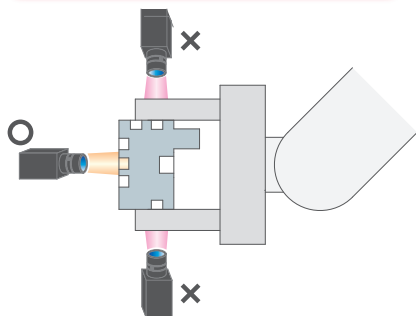

Interferes with the hand when holding a workpiece.

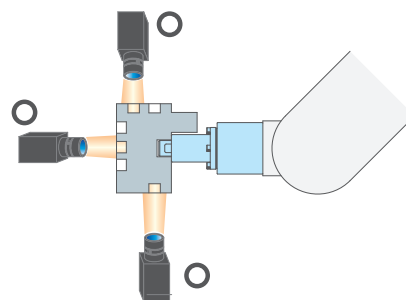

5 Faces Accessible with No Interference

High Power • Safety

Powerful gripping and clamping force with mechanical lock. The self-lock function with mechanical lock and internal spring will ensure safety even at 0MPa.

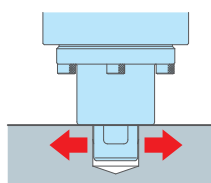

Gripping Force

Air 0.4MPa

1660N

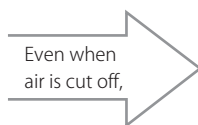

The built-in spring maintains clamping state.

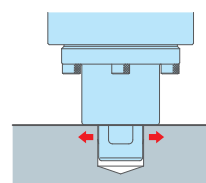

Gripping Force

Air 0MPa

220N

Action Description ※ This is a simplified drawing. The actual part components may be different.

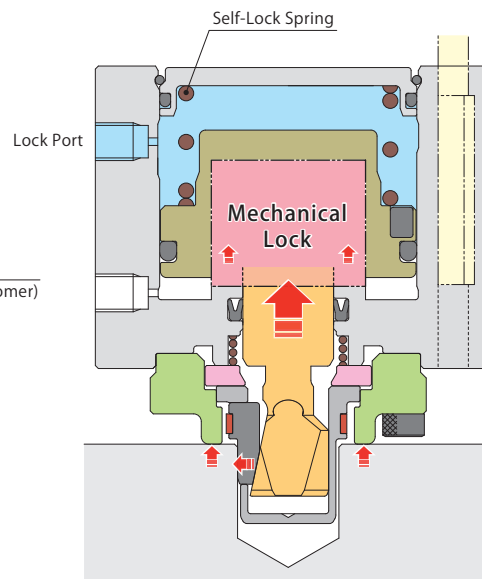
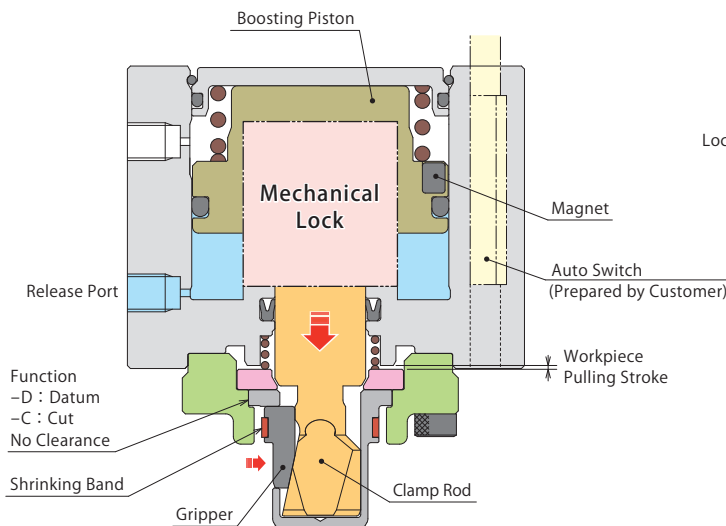

When Loading / Unloading (Release)

- ① Air is supplied to the release port.
- ↓
- ② Air pressure releases the internal mechanical lock and moves the clamp rod forward. The gripper will be retracted.

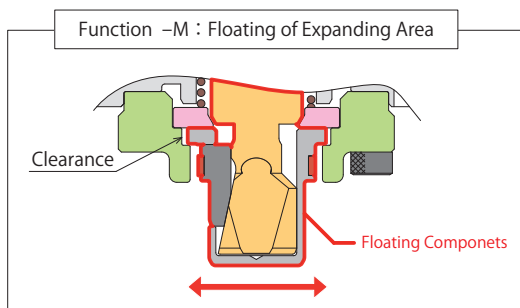

When Gripping / Clamping (Lock)

- ① Release air to the release port and supply air to the lock port.
- ↓
- ② The internal mechanical lock with self-locking spring force and air pressure powerfully pulls in the clamp rod. The gripper will be expanded.
- ↓
- ③ After the gripper holds a workpiece, the pulling force pulls in the workpiece onto the seating surface. (Clamping Force = Pulling Force toward Seating Surface)

[Caution]

This product has no function that prevents contaminants.
Do not use under environment with coolant and cutting chips.

For such environment, choose the pneumatic hole clamp (model SWA),
high-power pneumatic hole clamp (model SWE), or hole gripper (model WKK).

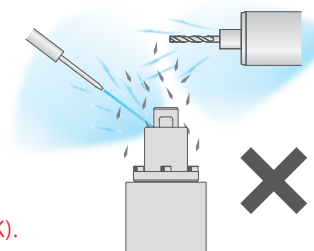

Auto Switch

Locking action and releasing action can be detected by an auto switch (prepared by customer).

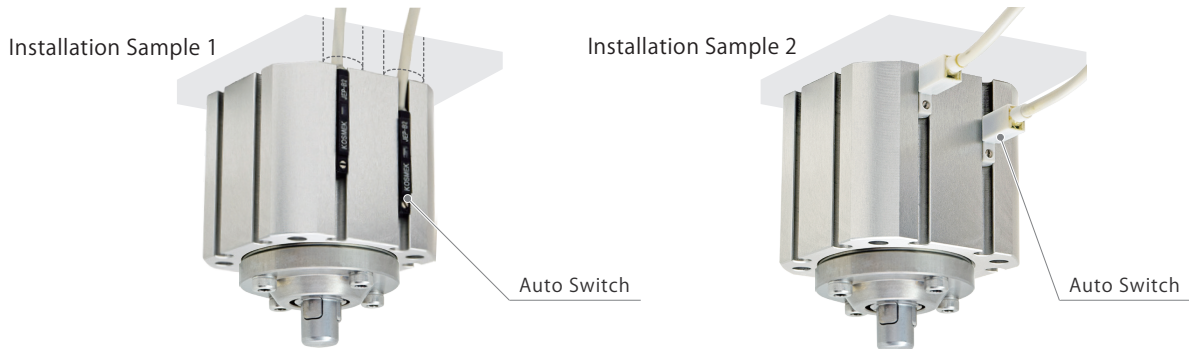

Note :

- Depending on difference of workpiece hole diameter, the detection range of an auto switch can be insufficient.

If using the auto switch (JEP), workpiece hole diameter difference should be within $\pm 0.1\text{mm}$.

【Applicable Auto Switch / High-Accuracy Sensor for Air Cylinder】

Switch Type	Model No.	Output Method	Wiring Method	Cable Length	Shape	Protection Grade
Auto Switch	JEP0000-B2	Non-Contact : NPN Output	3-Wire	1m	Straight	IP67
	JEP0000-B2L			3m		
	JEP0000-B3C			1m	L Shaped	
	JEP0000-B3CL			3m		
	JEP0000-B3B	Non-Contact	2-Wire	1m	L Shaped	
	JEP0000-B3BL			3m		
High-Accuracy Sensor for Air Cylinder ※1	JES0000-02GN	Non-Contact : NPN Output N-Pole Sensor※2	3-Wire	1m	Straight	IP67
	JES0000-02GS	Non-Contact : NPN Output S-Pole Sensor※2				
	JES0000-02GPN	Non-Contact : PNP Output N-Pole Sensor※2				
	JES0000-02GPS	Non-Contact : PNP Output S-Pole Sensor※2				
	JES0000-02LGN	Non-Contact : NPN Output N-Pole Sensor※2			L Shaped	
	JES0000-02LGS	Non-Contact : NPN Output S-Pole Sensor※2				
	JES0000-02LGPN	Non-Contact : PNP Output N-Pole Sensor※2				
	JES0000-02LGPS	Non-Contact : PNP Output S-Pole Sensor※2				

Notes :

- For further information, please refer to the following product pages.
Auto Switch (JEP) : P.405-P.414, High-Accuracy Sensor for Air Cylinder (JES) : P.287-P.290
When using an auto switch not made by Kosmek, check specifications of each manufacture.
 - Auto Switch / High-Accuracy Sensor for Air Cylinder may be stuck out of the clamp depending on the installation position and direction.
- ※1. The detection range of High-Accuracy Sensor for Air Cylinder (JES) is different from Auto Switch (JEP), and even small stroke can be securely detected by JES. Refer to "Performance Curve" on the JES catalog for further information.
- ※2. When detecting both lock and release actions with High-Accuracy Sensor for Air Cylinder (JES), both N-pole sensor and S-pole sensor are required.

Locating
+
Clamp

Locating

Hand • Clamp

Support

Valve • Coupler

Cautions • Others

Pallet Gripper

WVA

Locating
Pin Clamp

SWP

High-Power
Pull Stud Clamp

WPT

JES

FA Pneumatic
Hole Clamp

WKH

Lifting
Hole Clamp

SWJ

Ball Lock
Cylinder

WKA

Pneumatic
Robotic Hands

WPW-C

WPS-C

WPA

WPH

WPP

WPQ

Auto Switch
Proximity Switch

JEP

High-Power Pneumatic
Hole Clamp

SWE

High-Power Pneumatic
Swing Clamp

WHE

High-Power Pneumatic
Link Clamp

WCE

Pneumatic
Hole Clamp

SWA

Pneumatic
Swing Clamp

WHA

Double Piston
Pneumatic
Swing Clamp

WHD

Pneumatic
Link Clamp

WCA

Air Flow
Control Valve

BZW

Manifold
Block

WHZ-MD

Model No. Indication

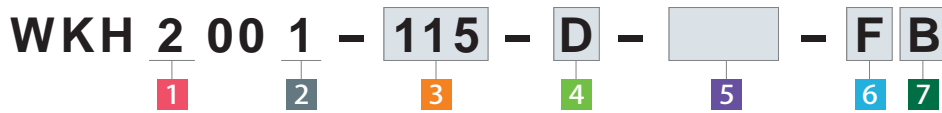

1 Body Size

2 : Standard

2 Design No.

1 : Revision Number

3 Workpiece Hole Diameter (Workpiece Hole Code)

Workpiece Hole Code : Workpiece Hole Diameter ϕd

※ Indicate the workpiece hole diameter ϕd in 0.5 increments from the allowable range in the list below.

※ When using with an auto switch, workpiece hole diameter difference should be within $\pm 0.1\text{mm}$.

※ The allowable tolerance of the hole mouth diameter ϕd differs depending on the slope angle. Refer to the Workpiece Hole Slope Angle and Allowable Tolerance of Hole Mouth Diameter on P.296

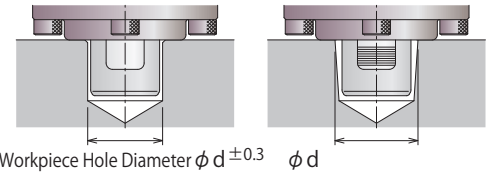

Workpiece Hole Shape: Straight

Workpiece Hole Shape: Tapered

Workpiece Hole Code	060	065	070	075	080	085	090	095	100	105	110	115	120	125	130	135	140
Hole Diameter $\phi d \pm 0.3$ (mm)	6	6.5	7	7.5	8	8.5	9	9.5	10	10.5	11	11.5	12	12.5	13	13.5	14

※ Taper hole model is not available for Workpiece Hole Code : 060.

4 Functions

- D** : Datum (For Reference Locating)
- C** : Cut (For One Direction Locating)
- M** : Floating of Expanding Area (No Locating Function)

※ When using it with expansion locating pin (model VWH, VWM, VWK, VRA, VRC, VX, etc.) please select Function **M**.

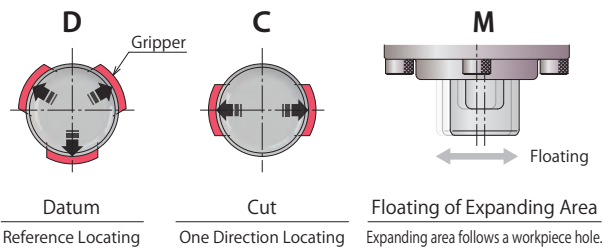

Workpiece Hole Code	060 ~ 085	090 ~ 140
Function D	Not Available	Available No. of Gripper : 3
Function C	Available No. of Gripper : 2	Available No. of Gripper : 2
Function M	Available No. of Gripper : 2	Available No. of Gripper : 3

※ When roughly locating with workpiece hole code 060~085, refer to P.303 "Clamp Installation".

5 Seating Height Dimension

Blank : Standard Height

H **Seating Height** : Specifying Seating Height (In 10mm increments)

Symbol	Blank (Standard)	H10	H20	H30	H40	H50
AA	50	60	70	80	90	100
AB	10	20	30	40	50	60

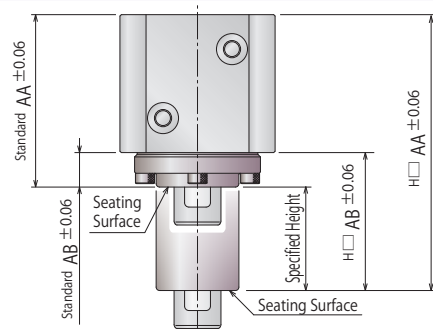

6 Shape of Gripper (Workpiece Hole)

- F** : No Serration (Standard)
- S** : With Serration
- T** : Taper Hole (With Serration) ※ Contact us for details.



7 Shape of Cap End

Blank : Standard (Low Head Model)

B : Cone Point Model

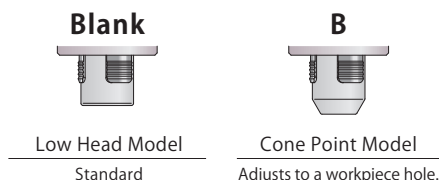

※ When inserting the cap adjusting to a workpiece hole, it should be within the floating range, or a workpiece should be light and not fixed.

Specifications

Model No.		WKH2001																		
	3 Workpiece Hole Code	060	065	070	075	080	085	090	095	100	105	110	115	120	125	130	135	140		
Machine Part	6 Workpiece Hole Shape S/F	Workpiece Hole Diameter $\phi d^{\pm 0.3}$ mm																		
	6 Workpiece Hole Shape T	Hardness																		
		Less than HB250 (When Selecting 6 S)																		
		Hole Mouth Diameter ϕd mm																		
		Please Refer to Workpiece Hole Slope Angle and Allowable Tolerance of Hole Mouth Diameter shown in the table below.																		
		Workpiece Hole Slope Angle																		
		Hardness																		
		Less than HB250																		
Locating Repeatability $\ast 1$		mm																		
		0.03 (When Combining 4 D/C)																		
Allowable Offset (Floating Clearance of Expanding Area) $\ast 2$		mm																		
		± 0.3 (When Selecting 4 M)																		
		± 0.5 (When Selecting 4 M)																		
Workpiece Pulling Stroke		mm																		
		0.5																		
Cylinder Capacity (Empty Action)		Release Side																	cm ³	
																			8.9	
		Lock Side																	cm ³	
																			8.5	
Maximum Operating Pressure		MPa																		
		0.5																		
Minimum Release Pressure		MPa																		
		0.2																		
Withstanding Pressure		MPa																		
		0.75																		
Operating Temperature		°C																		
		0 ~ 70																		
Usable Fluid																				
		Dry Air																		
Weight																				
		Please refer to External Dimensions for the product weight.																		

Notes:

$\ast 1$. Locating repeatability under the same condition (no load).

$\ast 2$. The expanding part of option M is an adjusting structure and the clamping operation is done by locating a workpiece hole. The value in the table shows the amount of tolerance value of single clamp. Please consider the distance accuracy of each clamp mounting hole and each workpiece machining hole when using with another location clamp / location cylinder, or when using more than two of these products.

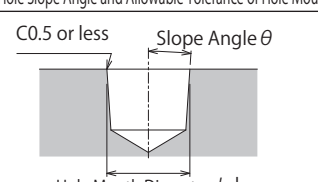
Workpiece Hole Slope Angle and Allowable Tolerance of Hole Mouth Diameter		Workpiece Hole Code	Slope Angle θ	Allowable Tolerance of Hole Mouth Diam.
	065 ~ 085		$1 \leq \theta \leq 2.5$	$\phi d^{\pm 0.3}$
			$2.5 < \theta \leq 3$	$\phi d^{\pm 0.15}$
	090		$1 \leq \theta \leq 2$	$\phi d^{\pm 0.3}$
			$2 < \theta \leq 2.5$	$\phi d^{\pm 0.15}$
	095 ~ 140		$1 \leq \theta \leq 2.5$	$\phi d^{\pm 0.3}$
			$2.5 < \theta \leq 3$	$\phi d^{\pm 0.15}$

\ast Please contact us when the slope angle is less than 1°

Gripping Force • Clamping Force Curve

Model No.		WKH2001	
		F : No Serration	S,T : With Serration
Gripping Force $\ast 3$	N	6 Shape of Gripper	
		Air Pressure 0.5 MPa	2020
		Air Pressure 0.4 MPa	1660
		Air Pressure 0.3 MPa	1300
		Air Pressure 0.2 MPa	940
		Air Pressure 0 MPa	220
Calculation Formula $\ast 5$		$F_H = 3600 \times P + 220$	
Clamping Force $\ast 4$ (Workpiece Pulling Force)	N	Air Pressure 0.5 MPa	188
		Air Pressure 0.4 MPa	152
		Air Pressure 0.3 MPa	117
		Air Pressure 0.2 MPa	81
		Air Pressure 0 MPa	10
		Calculation Formula $\ast 5$	

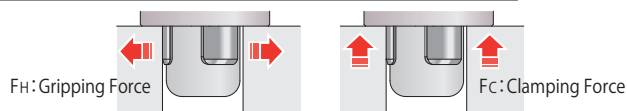
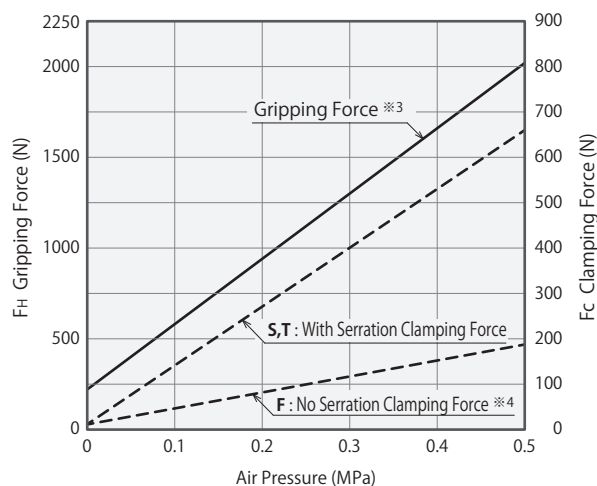

Notes:

- This graph shows the relationship among supply air pressure, gripping force and clamping force.
- Gripping force shows the expanding force acting perpendicular to the clamp's center axis. Clamping force shows the pressing force against the seating surface.
- Thin wall around the workpiece hole can be deformed by clamping action, gripping force and clamping force will not fill the specification.
- Gripping force shows the calculated value when the friction coefficient of expanding area is $\mu 0.15$.
- Clamping force of F: No Serration shows the calculated value when the friction coefficient of workpiece and gripper is $\mu 0.1$.
- F_H : Gripping Force (N), F_c : Clamping Force (N), P : Supply Air Pressure (MPa).

Locating + Clamp

Locating

Hand + Clamp

Support

Valve • Coupler

Cautions • Others

Pallet Gripper

WVA

Locating Pin Clamp

SWP

High-Power Pull Stud Clamp

WPT

JES

FA Pneumatic Hole Clamp

WKH

Lifting Hole Clamp

SWJ

Ball Lock Cylinder

WKA

Pneumatic Robotic Hands

WPW-C

WPS-C

WPA

WPH

WPP

WPQ

Auto Switch Proximity Switch

JEP

High-Power Pneumatic Hole Clamp

SWE

High-Power Pneumatic Swing Clamp

WHE

High-Power Pneumatic Link Clamp

WCE

Pneumatic Hole Clamp

SWA

Pneumatic Swing Clamp

WHA

Double Piston Pneumatic Swing Clamp

WHD

Pneumatic Link Clamp

WCA

Air Flow Control Valve

BZW

Manifold Block

WHZ-MD

External Dimensions

※ The drawing shows the released state of WKH2001-□-D-F.

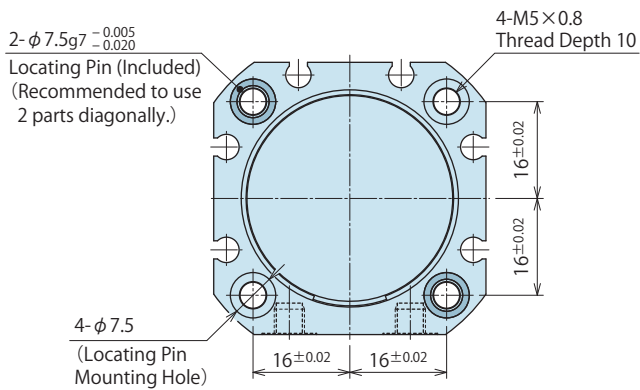

※ Expanding Area Detail

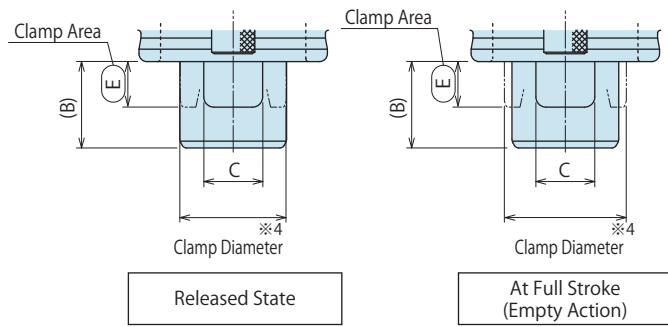

Seating Height: Standard

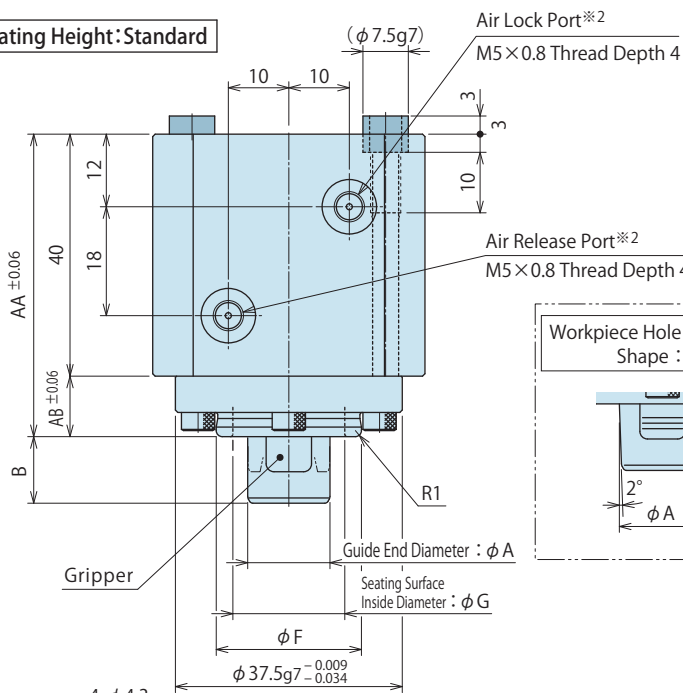

Specified Seating Height: H □^{※3}

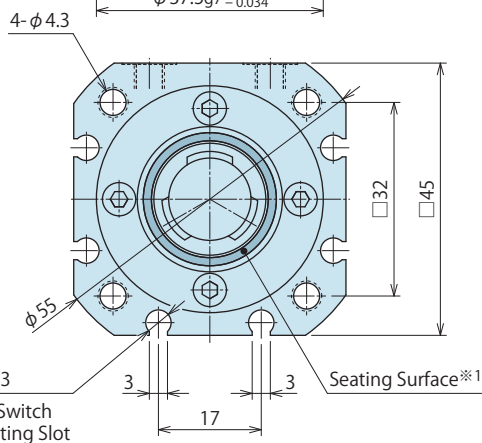
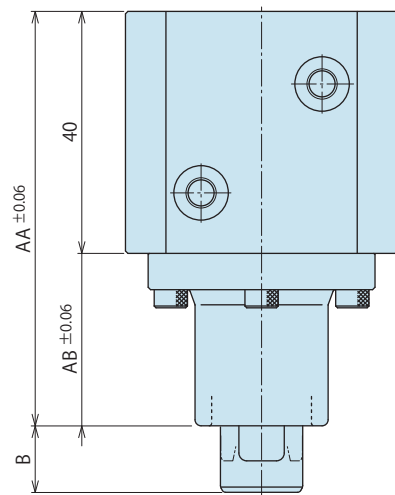

Notes :

1. Mounting bolts are not provided. Please prepare them according to the mounting position. (Refer to "Mounting Hole Clamp" on P.305.)
 2. This product locks with air pressure and self-locking spring and releases with air pressure. (When air drops to OMPa, it will be in the locked state with gripper expansion.)
- ※1. The workpiece must be resting on all seating surfaces when clamping. Otherwise the workpiece can be deformed by the clamping force.
- ※2. The name of each port is marked on the port. (LOCK: Air Lock Port, RELEASE: Air Release Port)
- ※3. Please refer to Seating Height: Standard for dimensions that is not shown.
- ※4. For -T: Taper Hole model, the first gripper ridge is the reference diameter.

Workpiece (Pallet) Hole Dimensions

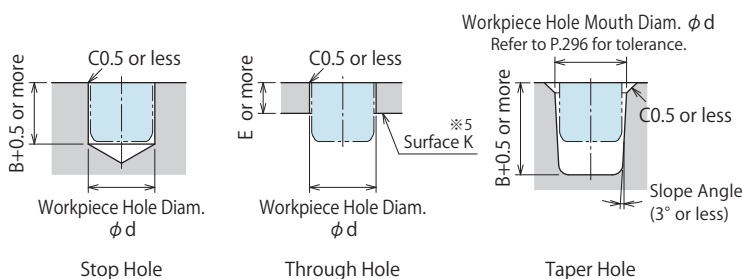

Notes :

1. Thin wall around the workpiece hole can be deformed by clamping action, gripping force and clamping force will not fill the specification. Please make sure to test the clamping function before using and adjust to the appropriate supply of pressure.
5. When the hole Clamp head is sticking above the surface K of the workpiece, please make sure there is no interference with the hole Clamp during machining.

Functions and Gripper Direction

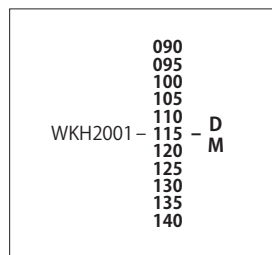

Number of Gripper: 3 (120° Interval)

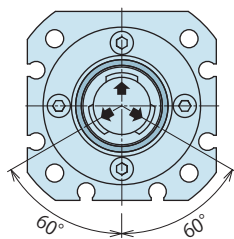

➤ shows the expanding direction of the gripper.

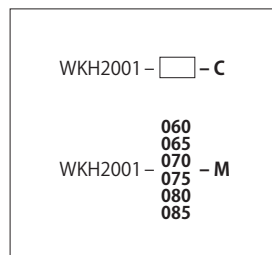

Number of Gripper: 2

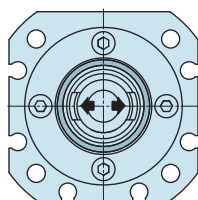

Mounting Direction of WKH2001-□-C

When locating with workpiece hole code **090 ~ 140**

※ The expanding direction of WKH2001-□-C must be vertical toward the line connecting the centers of WKH2001-□-D and WKH2001-□-C.

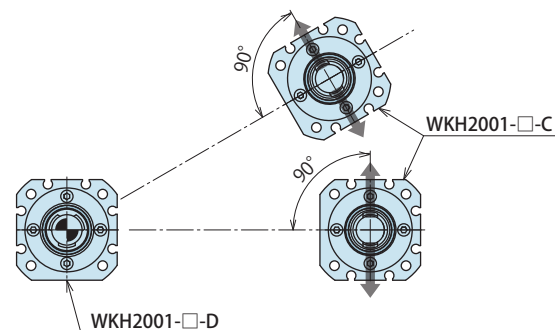

➤ shows the expanding direction of the gripper.

Model No. Indication

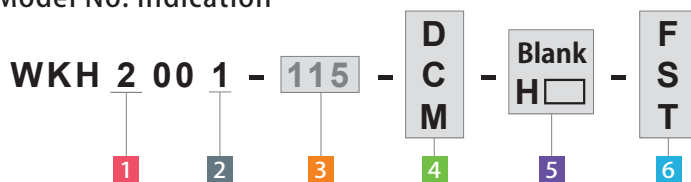

- 1 Body Size
- 2 Design No.
- 3 Workpiece Hole Diameter (Workpiece Hole Code)
- 4 Functions
- 5 Seating Height Dimension
- 6 Shape of Gripper (Workpiece Hole)

External Dimensions

Model No.		WKH2001-□-□-□-□																
3 Workpiece Hole Code		060	065	070	075	080	085	090	095	100	105	110	115	120	125	130	135	140
Workpiece Hole Diameter ϕ d	6 Shape of Gripper F,S※8	6 ±0.3	6.5 ±0.3	7 ±0.3	7.5 ±0.3	8 ±0.3	8.5 ±0.3	9 ±0.3	9.5 ±0.3	10 ±0.3	10.5 ±0.3	11 ±0.3	11.5 ±0.3	12 ±0.3	12.5 ±0.3	13 ±0.3	13.5 ±0.3	14 ±0.3
Clamp Diameter	At Release	5.5	6	6.5	7	7.5	8	8.5	9	9.5	10	10.5	11	11.5	12	12.5	13	13.5
6 Shape of Gripper F,S	At Idle	6.8	7.3	7.8	8.3	8.8	9.3	9.8	10.3	10.8	11.3	11.8	12.3	12.8	13.3	13.8	14.3	14.8
Clamp Diameter	At Release	-	5.7	6.2	6.7	7.2	7.7	8.2	8.5	9	9.5	9.95	10.45	10.95	11.45	11.95	12.45	12.95
6 Shape of Gripper T	At Idle	-	7	7.5	8	8.5	9	9.5	9.8	10.3	10.8	11.25	11.75	12.25	12.75	13.25	13.75	14.25
Workpiece Pulling Stroke		0.5																
6 Shape of Gripper F,S	A	5.6	6.1	6.6	7.1	7.6	8.1	8.6	9.1	9.6	10.1	10.6	11.1	11.6	12.1	12.6	13.1	13.6
	B	8	8	8	8	8	8	9.5	9.5	9.5	11	11	11	11	11	11	11	11
	C	2	2	2.5	2.5	3	3	4.5	4.5	5	5	5.5	5.5	6	6	6.5	6.5	7.5
	E	3.3	3.3	3.3	3.3	3.3	3.3	4.3	4.3	4.3	5.8	5.8	5.8	5.8	5.8	5.8	5.8	5.8
6 Shape of Gripper T	A	-	6	6.5	7	7.5	8	8.6	9	9.5	10	10.4	10.9	11.4	11.9	12.4	12.9	13.4
	B	-	8	8	8	8	8	9.5	9.5	9.5	9.5	11	11	11	11	11	11	11
	C	-	2	2	2.5	2.5	3	4.5	4.5	4.5	5	5	5	5.5	5.5	6	6.5	6.5
F		16	16	16	17	17	17	19	20	20	21	21	22	22	23	23	24	24
G		9.5	10.5	10.5	11.5	11.5	12	13.5	14.5	14.5	15.5	15.5	16.5	16.5	17.5	17.5	18.5	18.5
4 Function D	Locating Repeatability ※6	Not Available											0.03					
4 Function M	Allowable Offset (Floating Clearance of Expanding Area) ※7	±0.3											±0.5					

Notes : ※6. Locating repeatability under the same condition (no load).

※7. The clamping part is an adjusting structure and the clamping operation is done by locating a workpiece hole. The value in the table shows the amount of tolerance value of single clamp. Please consider the distance accuracy of each clamp mounting hole and each workpiece machining hole when using with another location clamp / location cylinder, or when using more than two of these products.

※8. For -T:Taper Hole model, the allowable tolerance of the hole mouth diameter differs depending on the slope angle. (Refer to P.296.)

5 Seating Height Dimension	Standard Seating Height	Specified Seating Height				
	Blank	H10	H20	H30	H40	H50
AA	50	60	70	80	90	100
AB	10	20	30	40	50	60
Weight kg	0.30	0.32	0.34	0.36	0.38	0.40

Locating + Clamp

Locating

Hand + Clamp

Support

Valve + Coupler

Cautions + Others

Pallet Gripper

WVA

Locating Pin Clamp

SWP

High-Power Pull Stud Clamp

WPT

JES

FA Pneumatic Hole Clamp

WKH

Lifting Hole Clamp

SWJ

Ball Lock Cylinder

WKA

Pneumatic Robotic Hands

WPW-C

WPS-C

WPA

WPH

WPP

WPQ

Auto Switch Proximity Switch

JEP

High-Power Pneumatic Hole Clamp

SWE

High-Power Pneumatic Swing Clamp

WHE

High-Power Pneumatic Link Clamp

WCE

Pneumatic Hole Clamp

SWA

Pneumatic Swing Clamp

WHA

Double Piston Pneumatic Swing Clamp

WHD

Pneumatic Link Clamp

WCA

Air Flow Control Valve

BZW

Manifold Block

WHZ-MD

External Dimensions

※ The drawing shows the released state of WKH2001-□-D-FB.

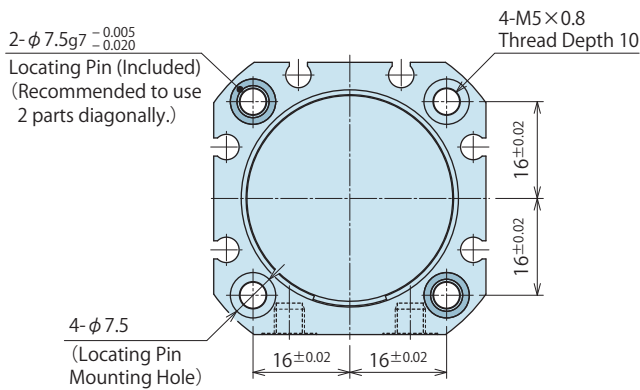

※ Expanding Area Detail

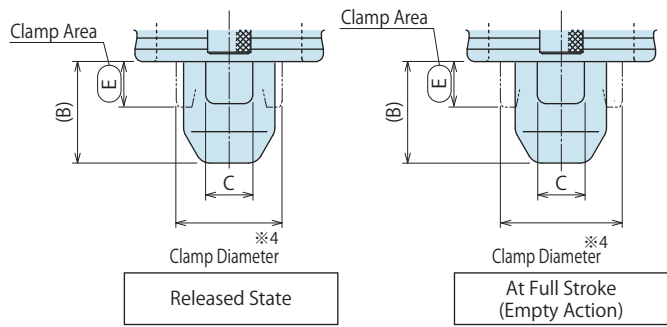

Seating Height: Standard

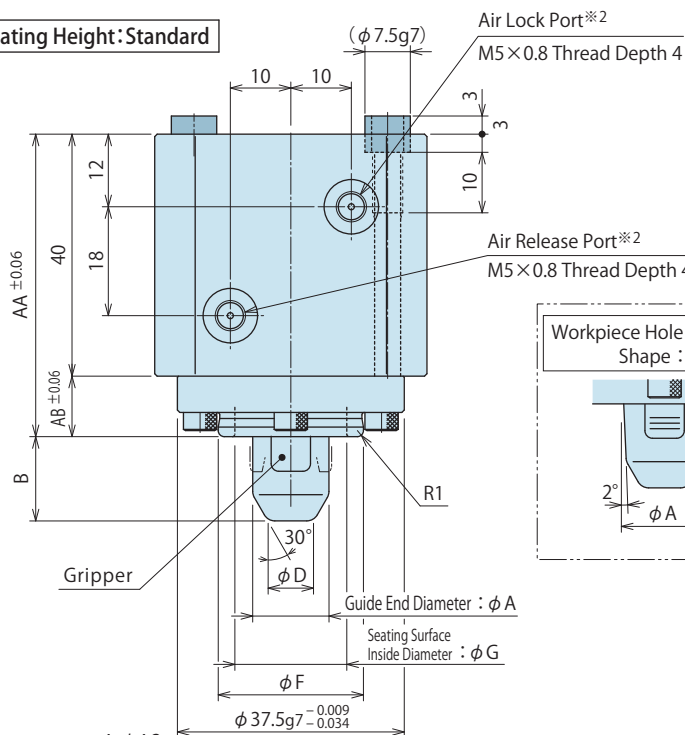

Specified Seating Height: H □^{※3}

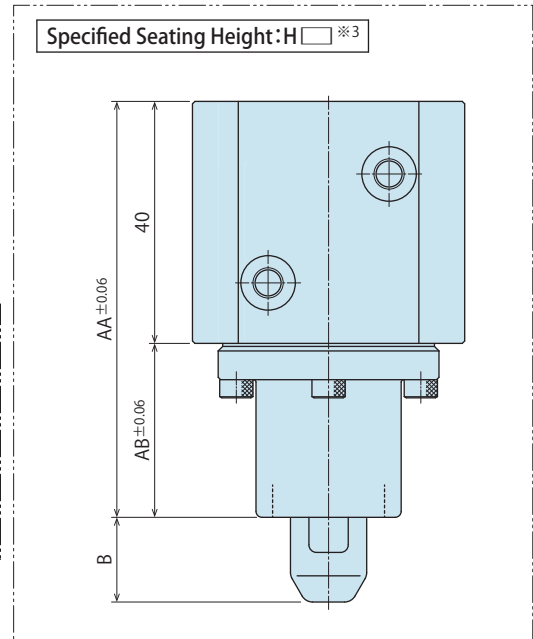

Notes :

1. Mounting bolts are not provided. Please prepare them according to the mounting position. (Refer to "Mounting Hole Clamp" on P.305.)
2. This product locks with air pressure and self-locking spring and releases with air pressure. (When air drops to 0MPa, it will be in the locked state with gripper expansion.)
- ※1. The workpiece must be resting on all seating surfaces when clamping. Otherwise the workpiece can be deformed by the clamping force.
- ※2. The name of each port is marked on the port. (LOCK: Air Lock Port, RELEASE: Air Release Port)
- ※3. Please refer to Seating Height: Standard for dimensions that is not shown.
- ※4. For -T: Taper Hole model, the first gripper ridge is the reference diameter.

Workpiece (Pallet) Hole Dimensions

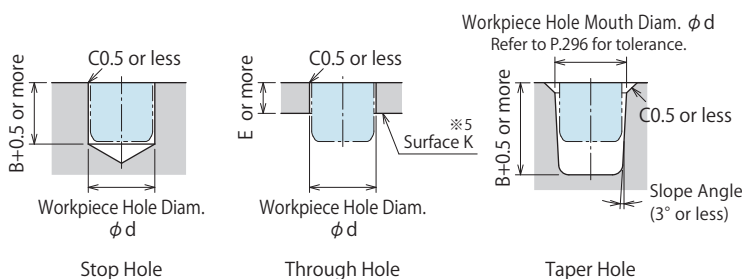

Notes :

1. Thin wall around the workpiece hole can be deformed by clamping action, gripping force and clamping force will not fill the specification. Please make sure to test the clamping function before using and adjust to the appropriate supply of pressure.
- ※5. When the hole Clamp head is sticking above the surface K of the workpiece, please make sure there is no interference with the hole Clamp during machining.

Functions and Gripper Direction

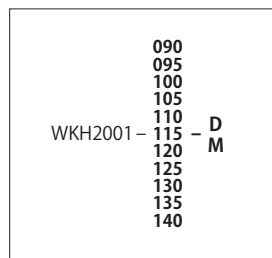

Number of Gripper : 3 (120° Interval)

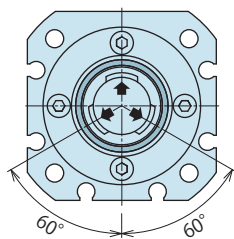

➡ shows the expanding direction of the gripper.

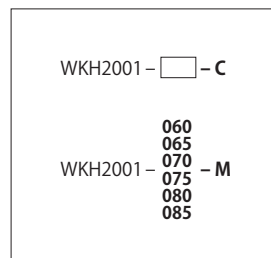

Number of Gripper : 2

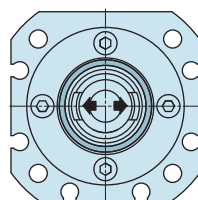

Mounting Direction of WKH2001-□-C

When locating with workpiece hole code **090 ~ 140**

※ The expanding direction of WKH2001-□-C must be vertical toward the line connecting the centers of WKH2001-□-D and WKH2001-□-C.

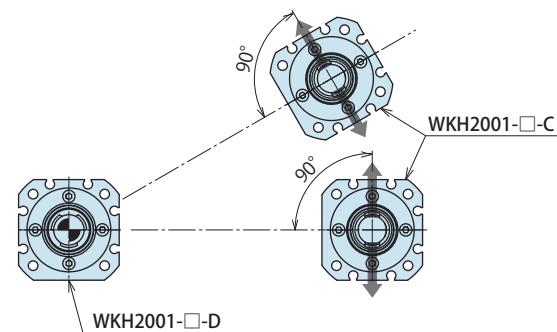

➡ shows the expanding direction of the gripper.

Model No. Indication

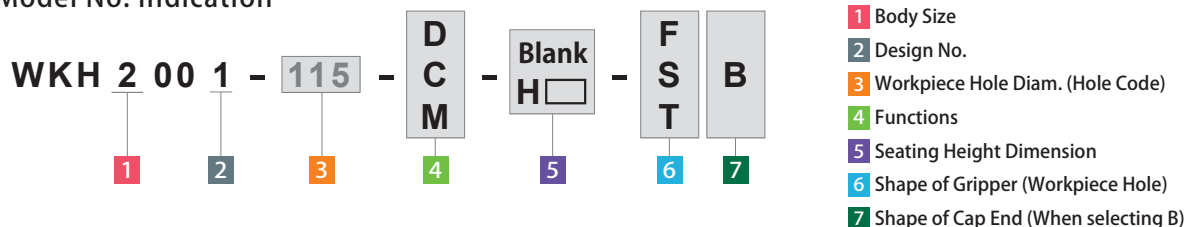

External Dimensions

Model No.	WKH2001-□-□-□-□B (mm)																	
3 Workpiece Hole Code	060	065	070	075	080	085	090	095	100	105	110	115	120	125	130	135	140	
Workpiece Hole Diameter φd	6 ^{±0.03}	6.5 ^{±0.03}	7 ^{±0.03}	7.5 ^{±0.03}	8 ^{±0.03}	8.5 ^{±0.03}	9 ^{±0.03}	9.5 ^{±0.03}	10 ^{±0.03}	10.5 ^{±0.03}	11 ^{±0.03}	11.5 ^{±0.03}	12 ^{±0.03}	12.5 ^{±0.03}	13 ^{±0.03}	13.5 ^{±0.03}	14 ^{±0.03}	
Clamp Diameter	At Release	5.5	6	6.5	7	7.5	8	8.5	9	9.5	10	10.5	11	11.5	12	12.5	13	13.5
	At Idle	6.8	7.3	7.8	8.3	8.8	9.3	9.8	10.3	10.8	11.3	11.8	12.3	12.8	13.3	13.8	14.3	14.8
Clamp Diameter	At Release	-	5.7	6.2	6.7	7.2	7.7	8.2	8.5	9	9.5	9.95	10.45	10.95	11.45	11.95	12.45	12.95
	At Idle	-	7	7.5	8	8.5	9	9.5	9.8	10.3	10.8	11.25	11.75	12.25	12.75	13.25	13.75	14.25
Workpiece Pulling Stroke	0.5																	
6 Shape of Gripper F,S	A	5.6	6.1	6.6	7.1	7.6	8.1	8.6	9.1	9.6	10.1	10.6	11.1	11.6	12.1	12.6	13.1	13.6
	B	9	9	9	10	10	10	11	11	11	13	13	13	13	14	14	14	14
	C	2	2	2.5	2.5	3	3	4.5	4.5	5	5	5.5	5.5	6	6	6.5	6.5	7.5
	D	3.5	4	4.5	4	4.5	5	5.4	5.9	6.4	6.3	6.8	7.3	7.8	7.1	7.6	8.1	8.6
	E	3.3	3.3	3.3	3.3	3.3	3.3	4.3	4.3	4.3	5.8	5.8	5.8	5.8	5.8	5.8	5.8	5.8
6 Shape of Gripper T	A	-	6	6.5	7	7.5	8	8.6	9	9.5	10	10.4	10.9	11.4	11.9	12.4	12.9	13.4
	B	-	9	9	9	10	10	11	11	11	11	13	13	13	13	14	14	14
	C	-	2	2	2.5	2.5	3	4.5	4.5	4.5	5	5	5	5.5	5.5	6	6.5	6.5
	D	-	3.2	3.7	4.2	3.6	4.1	5.2	5.5	6	6.5	6.3	6.8	7.3	7.8	7.1	7.6	8.1
	E	-	3.3	3.3	3.3	3.3	3.3	4.3	4.3	4.3	4.3	5.8	5.8	5.8	5.8	5.8	5.8	5.8
F	16	16	16	17	17	17	19	20	20	21	21	22	22	23	23	24	24	
G	9.5	10.5	10.5	11.5	11.5	12	13.5	14.5	14.5	15.5	15.5	16.5	16.5	17.5	17.5	18.5	18.5	
4 Function D Locating Repeatability ^{※6}	Not Available										0.03							
4 Function M Allowable Offset (Floating Clearance of Expanding Area) ^{※7}	±0.3										±0.5							

Notes : ※6. Locating repeatability under the same condition (no load).

※7. The clamping part is an adjusting structure and the clamping operation is done by locating a workpiece hole. The value in the table shows the amount of tolerance value of single clamp. Please consider the distance accuracy of each clamp mounting hole and each workpiece machining hole when using with another location clamp / location cylinder, or when using more than two of these products.

※8. For -T:Taper Hole model, the allowable tolerance of the hole mouth diameter differs depending on the slope angle. (Refer to P.296.)

5 Seating Height Dimension	Standard Seating Height					
	Blank	H10	H20	H30	H40	H50
AA	50	60	70	80	90	100
AB	10	20	30	40	50	60
Weight kg	0.30	0.32	0.34	0.36	0.38	0.40

Locating + Clamp

Locating

Hand + Clamp

Support

Valve + Coupler

Cautions + Others

Pallet Gripper

WVA

Locating Pin Clamp

SWP

High-Power Pull Stud Clamp

WPT

JES

FA Pneumatic Hole Clamp

WKH

Lifting Hole Clamp

SWJ

Ball Lock Cylinder

WKA

Pneumatic Robotic Hands

WPW-C

WPS-C

WPA

WPH

WPP

WPQ

Auto Switch Proximity Switch

JEP

High-Power Pneumatic Hole Clamp

SWE

High-Power Pneumatic Swing Clamp

WHE

High-Power Pneumatic Link Clamp

WCE

Pneumatic Hole Clamp

SWA

Pneumatic Swing Clamp

WHA

Double Piston Pneumatic Swing Clamp

WHD

Pneumatic Link Clamp

WCA

Air Flow Control Valve

BZW

Manifold Block

WHZ-MD

● Sample 1 (Layout and Circuit)

Combination Use with Pneumatic Expansion Locating Pin (model VWM) for High Accuracy Locating (Repeatability : 3 μm)

※ This drawing shows a layout sample of WKH-M (FA Pneumatic Hole Clamp) and VWM (Pneumatic Expansion Locating Pin).

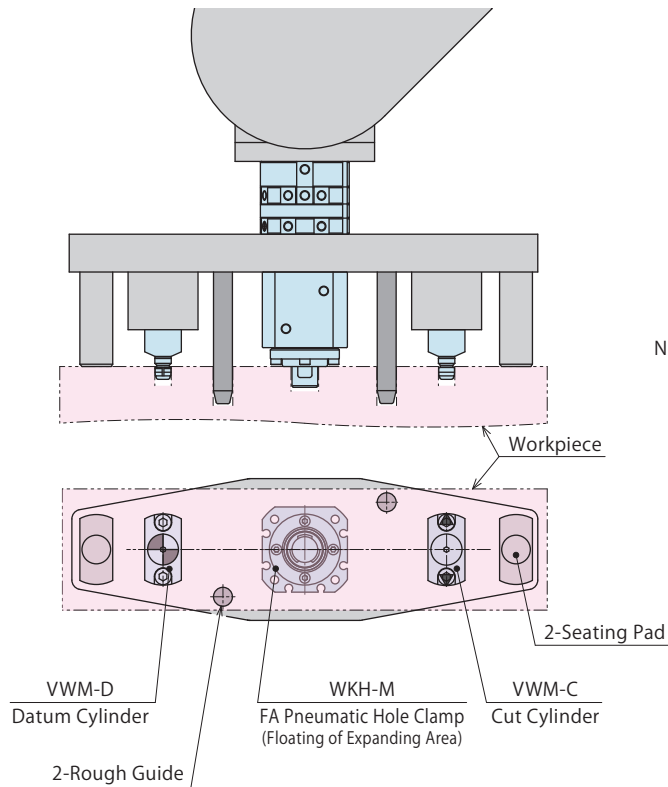

Notes :

1. When loading/unloading a workpiece, install two or more rough guides in order to prevent damage to a clamping part.
2. When using with VWM (Pneumatic Expansion Locating Pin), choose Function:M Floating of Expanding Area for FA Pneumatic Hole Clamp.

When Controlled with One Solenoid Valve

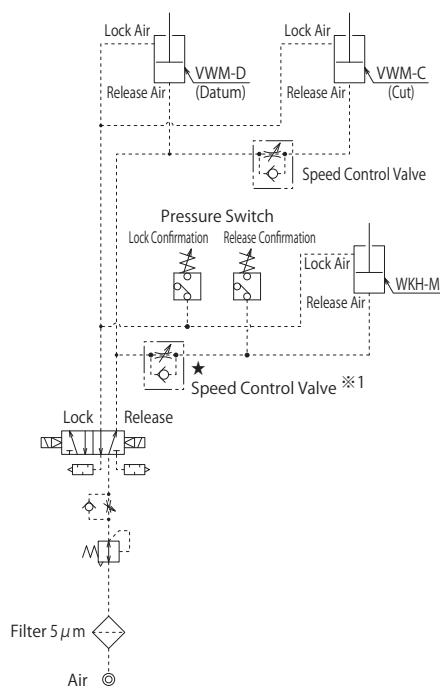

When Controlled with Two Solenoid Valves

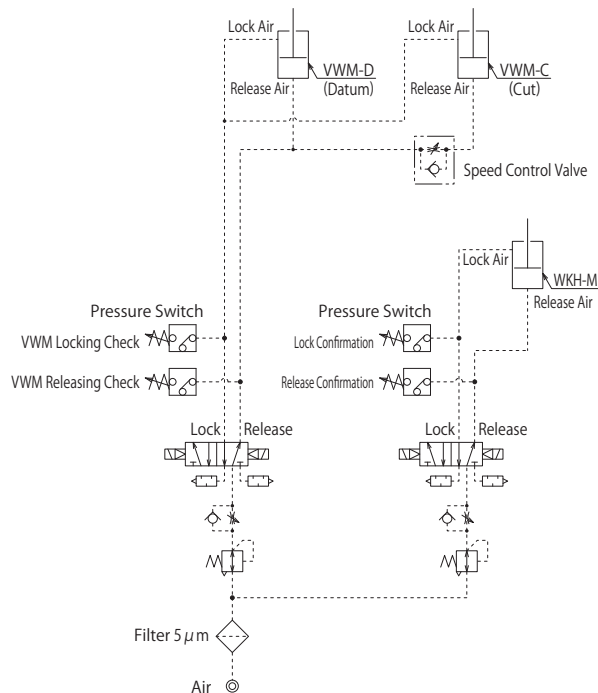

Note :

- ※ 1. Please use solenoid valve to make a sequence operation that WKH (Hole Clamp) starts working after VWM (Pneumatic Expansion Locating Pin) completes the movement. When unable to use solenoid valve, please prepare flow control valve with check valve at ★(1 part) to adjust sequencing speed. If WKH operates before VWM, there is a possibility for the equipment to be damaged due to a thrust load on WKH.

Sample 2 (Layout and Circuit)

Combination Use with High-Power Pneumatic Work Support (model WNC) for Workpiece Inclination Prevention During Transfer

When the gravity center of a workpiece is unbalanced, it could damage a clamp or drop a workpiece affected by inertia moment due to high-speed transfer (sudden stop). Use work supports, etc. when designing a system.

※ This drawing shows a layout sample of WKH-D/C (FA Pneumatic Hole Clamp), WNC (High-Power Pneumatic Work Support) and BWD (Air Sequence Valve).

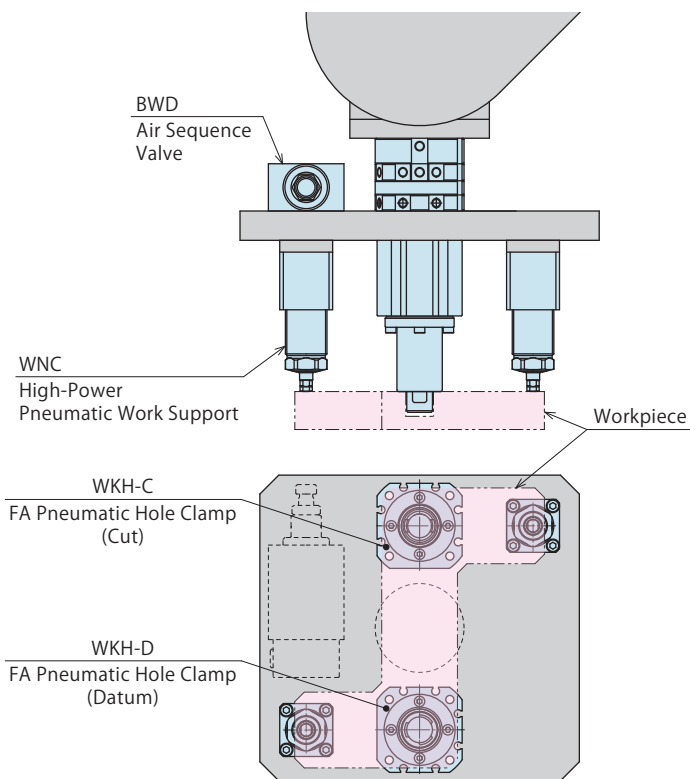

Locating + Clamp
Locating
Hand + Clamp
Support
Valve + Coupler
Cautions + Others
Pallet Gripper
WVA
Locating Pin Clamp
SWP
High-Power Pull Stud Clamp
WPT
JES
FA Pneumatic Hole Clamp
WKH
Lifting Hole Clamp
SWJ
Ball Lock Cylinder
WKA
Pneumatic Robotic Hands
WPW-C
WPS-C
WPA
WPH
WPP
WPQ
Auto Switch Proximity Switch
JEP
High-Power Pneumatic Hole Clamp
SWE
High-Power Pneumatic Swing Clamp
WHE
High-Power Pneumatic Link Clamp
WCE
Pneumatic Hole Clamp
SWA
Pneumatic Swing Clamp
WHA
Double Piston Pneumatic Swing Clamp
WHD
Pneumatic Link Clamp
WCA
Air Flow Control Valve
BZW
Manifold Block
WHZ-MD

When Controlled with One Solenoid Valve

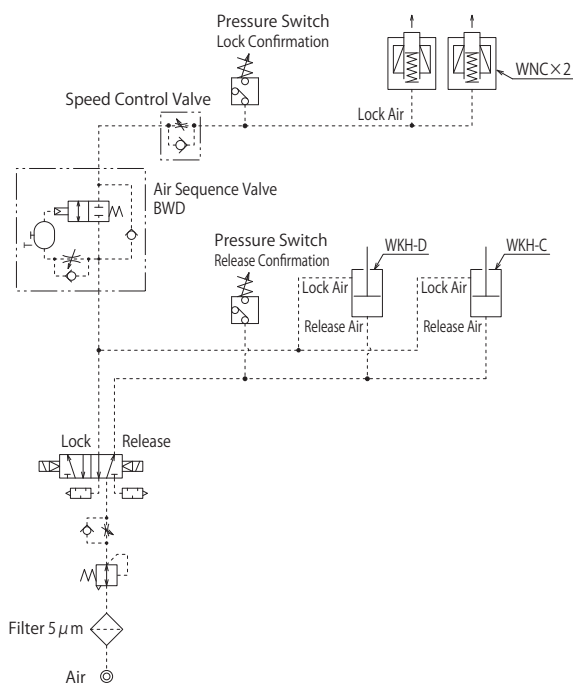

When Controlled with Two Solenoid Valves

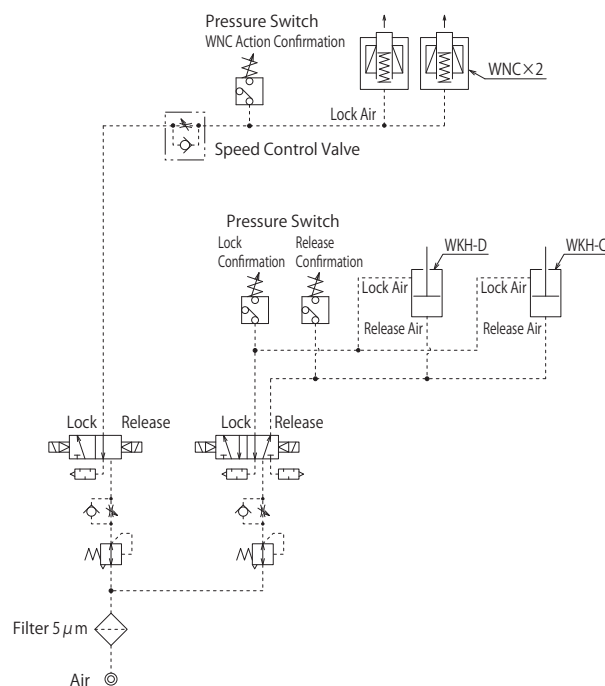

Note :

- ※1. Please use solenoid valve or BWD (Air Sequence Valve) to make a sequence operation that WKH (Hole Clamp) starts working after WNC (High-Power Pneumatic Work Support) completes the movement. If WKH operates before WNC, there is a possibility for the equipment to be damaged due to a thrust load on WKH.

Cautions

● Notes for Design

1) Check Specifications

- Please use each product according to its specifications.
- This product is an air double-acting clamp which locks with air pressure and spring force (gripping and clamping), and releases with air pressure. Even when air is not supplied to either lock or release port, the built-in spring maintains clamped state (clamp diameter is expanded).
- ① Gripping and clamping force at zero pressure is lower than those when air is supplied. For using at zero pressure, please refer to P.296 Gripping · Clamping Force Curve : Air Pressure 0 MPa.
- ② Supply the release air when loading/unloading a workpiece. Otherwise the workpiece contacts the grippers leading to damage to workpiece or clamp.

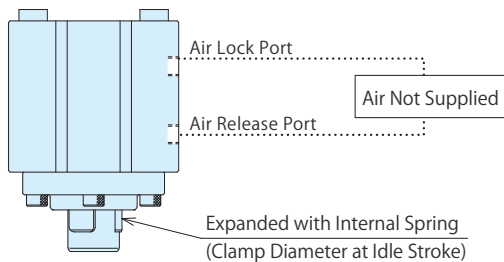

2) Working Reference Plate (Seating Surface) Z Axis

- The upper surface of the flange of this product is the seating surface of workpiece and locates in Z direction.

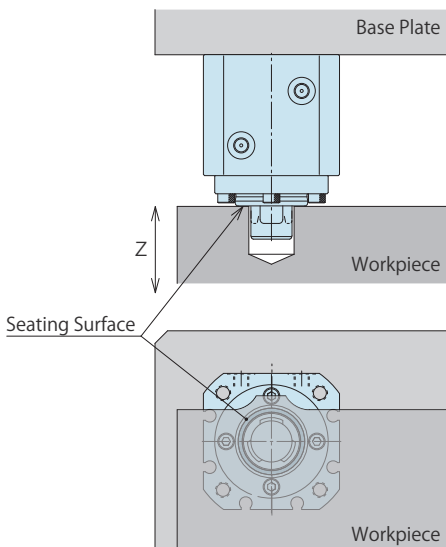

A workpiece must be resting on all seating surfaces when clamping. If not, calculate contacting pressure with clamping force and seating area not to deform a workpiece.

3) Wall Thickness around Workpiece Hole

- Thin wall around the workpiece hole can be deformed by clamping action, gripping and clamping forces do not fill the specification. Please conduct clamping test and adjust to proper air pressure before use. If clamping force is insufficient, workpiece may fall out.

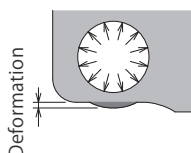

4) Clamp Installation

- When Using Functions -D/C

-C : Cut locates the orientation using -D : Datum as a reference. Therefore, it is required to determine the phase of -C : Cut when mounting.

When locating with workpiece hole code **090 ~ 140**
(When using Function -D and -C together)

The expanding direction of WKH2001-□-C must be vertical toward the line connecting the centers of WKH2001-□-D and WKH2001-□-C.

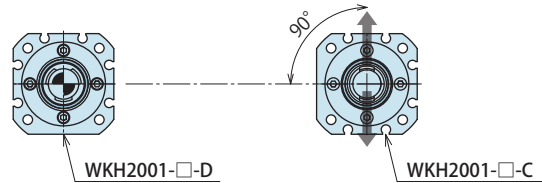

➡ shows the expanding direction of the gripper.

When roughly locating with workpiece hole code **060 ~ 085**
(When using Function -C and -C together)

Rotate 90° of the expanding direction of two clamps toward the line connecting the centers of two WKH2001-□-C. (Accuracy is not guaranteed since there is no reference locating.)

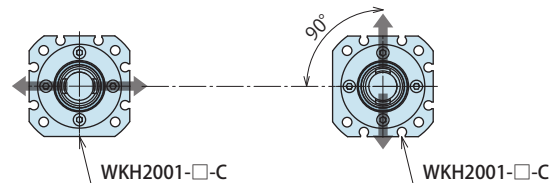

➡ shows the expanding direction of the gripper.

- When Using Functions -M : Floating of Expanding Area

-M has the floating function (workpiece hole diameter $\Phi 6 \sim \Phi 8.5 : \pm 0.3\text{mm}$, workpiece hole diameter $\Phi 9 \sim \Phi 14 : \pm 0.5\text{mm}$). Please consider the distance accuracy of each clamp mounting hole and each workpiece machining hole when using with another location clamp / location cylinder, or when using more than two of these products.

5) Clamping Force

- Clamping force shows pressing force against the seating surface. Please conduct clamping test and adjust to proper air pressure before use. Insufficient clamping force causes a workpiece to fall.

6) Workpiece hole size, slope angle and workpiece hardness should be within the range of the specification.

When workpiece hole diameter is larger than specification.	Expansion stroke is insufficient and the gripping force · clamping force will not fill the specifications.
When using it with insufficient gripping (clamping) force.	Leads to falling of the workpiece.
When workpiece hole diameter is smaller than specification.	Difficult to attach/detach the workpiece leading to damage.
When workpiece hole depth is shallow.	May lead to abnormal seating and damage.
When workpiece hole taper is larger than standard.	The load concentrates on the gripper point when clamping and could lead to damage.
When workpiece hole is harder than specified.	Gripper does not dig into work enough and it cannot clamp securely.

7) Horizontal Locating

- When a workpiece is set, please make sure there is no lifting or slope of the workpiece. If the clamping operation is done with lifting or slope of the workpiece, it will lead to possible damage of a clamp and deformation of the workpiece hole.

8) Please detach a workpiece with all clamps fully released.

- When detaching a workpiece during lock or release operation, it may cause damage to the clamp or cause the workpiece to fall.

9) Please set up rough guides.

- When detaching a workpiece with slope it may cause the damage to the clamp or cause the workpiece to fall.

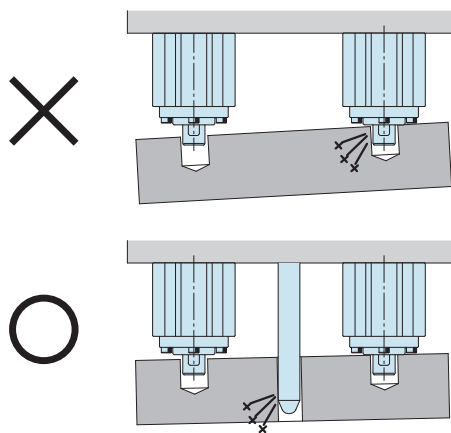

Please set up rough guides considering the pitch accuracy of location clamp / location cylinder mounting hole and each workpiece machining hole when using with another location clamp / location cylinder, etc.

10) For Use of Auto Switch

- Select an auto switch depending on the environment.
- An auto switch may be stuck out of the clamp depending on the installation position and direction.
- **2-wire reed auto switch cannot be used.**
- Depending on difference of workpiece hole diameter, the detection range of an auto switch can be insufficient.

If using the auto switch, workpiece hole diameter difference should be within $\pm 0.1\text{mm}$.

11) Fall Prevention Measures

- In case of accident such as detachment of a workpiece, please prepare fall prevention measures for safety.

12) Operating Environment

This product has no function that prevents contaminants. Do not use under environment with coolant and cutting chips. For such environment, choose the pneumatic hole clamp (model SWA), high-power pneumatic hole clamp (model SWE), or hole gripper (model WKK).

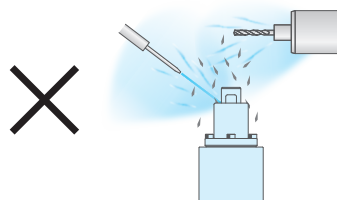

13) Damage Prevention during Robot Handling, etc.

- When inserting the Hole Clamp tip into/taking it out of a workpiece hole, the Hole Clamp tip has to be vertical to the workpiece hole.

Especially after releasing a workpiece, the Hole Clamp tip must be fully taken out from the workpiece hole before moving to a next coordinate.

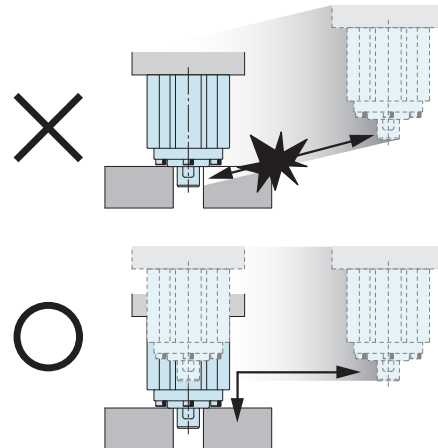

- If the Hole Clamp tip touches a workpiece when inserting, control the insertion speed to avoid damage on the workpiece and Hole Clamp tip.
- When the Hole Clamp is mounting/removing a workpiece, make sure that a robot operates only after the Clamp completes clamping/releasing action by using a sensor or timer. If the robot starts operating in the middle of clamping/releasing action, the workpiece may be fallen off.
- When mounting/removing a workpiece, it may be tilted due to a gap between the workpiece and the stand. This causes damage of the Hole Clamp. The gap has to be minimized as much as possible when mounting/removing.

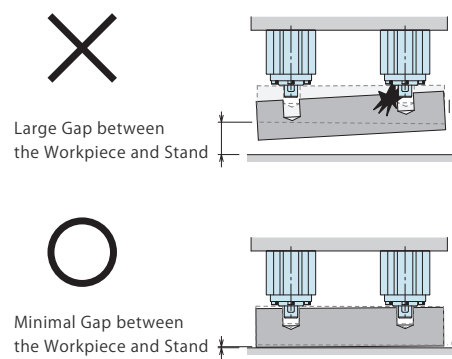

Locating + Clamp

Locating

Hand + Clamp

Support

Valve + Coupler

Cautions + Others

Pallet Gripper

WVA

Locating Pin Clamp

SWP

High-Power Pull Stud Clamp

WPT

JES

FA Pneumatic Hole Clamp

WKK

Lifting Hole Clamp

SWJ

Ball Lock Cylinder

WKA

Pneumatic Robotic Hands

WPW-C

WPS-C

WPA

WPH

WPP

WPK

Auto Switch Proximity Switch

JEP

High-Power Pneumatic Hole Clamp

SWE

High-Power Pneumatic Swing Clamp

WHE

High-Power Pneumatic Link Clamp

WCE

Pneumatic Hole Clamp

SWA

Pneumatic Swing Clamp

WHA

Double Piston Pneumatic Swing Clamp

WHD

Pneumatic Link Clamp

WCA

Air Flow Control Valve

BZW

Manifold Block

WHZ-MD

Cautions

Installation Notes

- 1) Check the fluid to use.
 - Please supply filtered clean dry air.
 - Oil supply with a lubricator etc. is unnecessary.
- 2) Preparation for Piping
 - The pipeline, piping connector and fixture circuits should be cleaned and flushed thoroughly.
The dust and cutting chips in the circuit may lead to fluid leakage and malfunction.
 - There is no filter provided with this product for prevention of contaminants in the air circuit.
- 3) Applying Sealing Tape
 - Wrap with tape 1 to 2 times following the screwing direction.
 - Pieces of the sealing tape may lead to air leaks and malfunction.
 - In order to prevent contaminants from entering into the product during the piping work, it should be carefully cleaned before working.
- 4) Mounting Hole Clamp
 - When mounting the product use four hexagon socket bolts (with tensile strength of A2-70 or more) and tighten them with the torque shown in the list below.
Tightening with greater torque than recommended can depress the seating surface or break the bolt.

Model No.	Thread Size	Tightening Torque (N·m)
WKH2001	M4×0.7	2.5
	M5×0.8	5.0

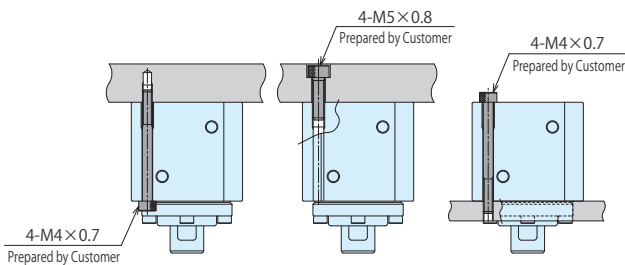

5) Port Position of Hole Clamp

- The name of each port is marked on the flange surface.
Be careful with the mounting direction of piping.
(LOCK : Air Lock Port, RELEASE : Air Release Port)

Notes on Handling

- 1) It should be operated by qualified personnel.
 - The hydraulic machine and air compressor should be operated and maintained by qualified personnel.
- 2) Do not operate or remove the product unless the safety protocols are ensured.
 - ① The machine and equipment can only be inspected or prepared when it is confirmed that the safety devices are in place.
 - ② Before the product is removed, make sure that the above-mentioned safety devices are in place. Shut off the pressure and power source, and make sure no pressure exists in the air and hydraulic circuits.
 - ③ After stopping the product, do not remove until the temperature drops.
 - ④ Make sure there is no trouble/issue in the bolts and respective parts before restarting the machine or equipment.
- 3) Do not touch workpieces (pallets) or clamps while they are working. Otherwise, your hands may be injured.



- 4) When transferring a workpiece, make sure the safety of environment in case of a workpiece detachment.
- 5) Do not disassemble or modify.
 - If the equipment is taken apart or modified, the warranty will be voided even within the warranty period.
 - Powerful spring is built in inside which is very dangerous.

● Maintenance and Inspection

1) Removal of the Product and Shut-off of Pressure Source

- Before removing the product, make sure that safety devices and preventive devices are in place. Shut off the pressure and power source, and make sure no pressure exists in the air and hydraulic circuits.
- Make sure there is no trouble/issue in the bolts and respective parts before restarting.

2) Regularly clean the clamping part and seating surface.

- If operating with dirt adhering to the clamping part, it will lead to damage to a product and workpiece detachment due to gripping force and clamping force shortage, defective operation, and air leakage, etc.

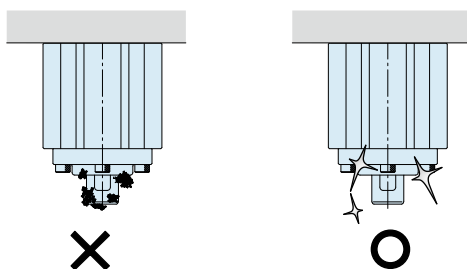

3) Regularly tighten pipe line and mounting bolt to ensure proper use.

- 4) Clamping force will be decreased by friction of a gripper surface due to repeated operation. Replacement period differs depending on operating pressure, workpiece material and shape of hole. When you find friction on gripper surface, the gripper needs to be replaced. Please contact us for overhaul.

Material of Clamping Hole	Gripper Replacement Frequency Guide
A2017 Aluminum	Locking operation 1 million cycles
SCM435 Thermal Refined Steel	Locking operation 500,000 cycles

※ It varies depending on the operating conditions. Please request an overhaul after confirming its suitability for the actual machine.

5) Make sure there is a smooth action without an irregular noise.

- Especially when it is restarted after left unused for a long period, make sure it can be operated correctly.
- 6) The products should be stored in the cool and dark place without direct sunshine or moisture.
- 7) Please contact us for overhaul and repair.

Powerful spring is built in inside which is very dangerous.

Model No. Indication

JEP 000 0 - A1 L

1 2 3



1 Design No.

0 : Revision Number

2 Switch Type

- A1** : 2-Wire Reed Auto Switch
- A2** : 2-Wire Reed Auto Switch
- A2V** : 2-Wire L-Shaped Reed Auto Switch
- B1** : 3-Wire Solid State Auto Switch*2
- B2** : 3-Wire Solid State Auto Switch*2
- B3C** : 3-Wire L-Shaped Solid State Auto Switch*2
- B3B** : 2-Wire L-Shaped Solid State Auto Switch
- P** : 3-Wire Proximity Switch for Gripping Detection (Length 32mm)*1
- P2** : 3-Wire Proximity Switch for Gripping Detection (Length 16mm)*1

Notes :
 *1. Please contact us for PNP output.
 *2. Please consider using model JES for PNP output.

3 Electric Cable Length *3

Blank : 1m
L : 3m

Note :
 *3. 3 Electric Cable Length is chosen only for A□/B□ Auto Switch of 2 Switch Type. For P□: Proximity Switch for Gripping Detection, electric cable length is all 2m.

Application Table

Switch Type	2-Wire Reed Auto Switch		3-Wire Solid State Auto Switch			2-Wire Solid State Auto Switch	Switch Type	3-Wire Proximity Switch for Gripping Detection	
	Model No.	JEP0000-A1□ JEP0000-A2□ JEP0000-A2V□	JEP0000-B1□	JEP0000-B2□	JEP0000-B3C□	JEP0000-B3B□		Model No.	JEP0000-P
SWJ2000				●	●	●	WPP0300	●	●
SWP050□				●	●	●	WPP0400	●	●
SWP100□				●	●	●	WPP0500	●	●
WCC □□		●		●	●	●	WPP0600	●	●
WCG □□-T		●		●	●	●	WPP0800	●	●
WFC □□		●		●	●	●	WPP1000	●	●
WHC □□		●		●	●	●	WPP1250	●	●
WHG □□-T		●		●	●	●	WPQ0200	●	●
WKH200□				●	●	●	WPQ0250	●	●
WKK100□				●	●	●	WPQ0300	●	
WKK200□				●	●	●	WPQ0400	●	
WPA0120		●		●	●	●	WPQ0500	●	
WPA0160		●		●	●	●	WPQ0600	●	
WPA0200		●		●	●	●	WPQ0800	●	
WPA0250		●		●	●	●	WPQ1000	●	
WPB0160		●		●	●	●			
WPB0200		●		●	●	●			
WPB0250		●		●	●	●			
WPE0160		●		●	●	●			
WPE0200	●		●						
WPE0300	●		●						
WPE0400	●		●						
WPE0500	●		●						
WPE0800	●		●						
WPF0100			Not Applicable						
WPF0120		●		●	●	●			
WPF0160		●		●	●	●			
WPF0200	●		●						
WPF0300	●		●						
WPH0100		●		●	●	●			
WPH0160		●		●	●	●			
WPH0200	●		●						
WPJ0120			Not Applicable						
WPJ0160		●		●	●	●			
WPJ0200	●		●						
WPJ0250	●		●						
WPJ0300	●		●						
WPJ0400	●		●						
WPS0160-C		●		●	●	●			
WPS0200-C		●		●	●	●			
WPW0500-C				●	●	●			
WPW0600-C				●	●	●			
WVGT □□-T				●	●	●			

● JEP0000-A□□ (2-Wire Reed Auto Switch)

● Specifications

Model No.	JEP0000-A1	JEP0000-A1L	JEP0000-A2	JEP0000-A2L	JEP0000-A2V	JEP0000-A2VL
Name	Reed Auto Switch					
Wiring Type	2-Wire					
Applicable Load	Relay, Programmable Logic Controller (PLC)					
Load Voltage / Load Current	Less than DC24V / 40mA Less than AC100V / 20mA					
Internal Voltage Drop	Less than 3V					
Operating Time	1ms					
Ambient Temperature	-10 ~ 60°C					
Withstand Voltage	AC1500V (There should be no abnormalities in 1 min. application.)					
Leakage Current	0					
Shock Resistance	30G					
Protection Circuit	None					
Protection Grade	IP67 (IEC Standard)					
Indicator Light	Red LED illuminates when turned ON					
Electric Cable Length	1m	3m	1m	3m	1m	3m

● Electric Circuit Diagram

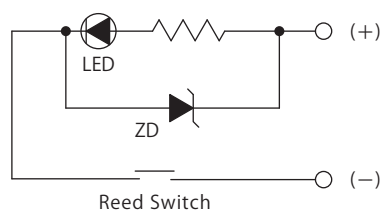

Note :

1. Auto switch will instantly break due to over loading current if turning on the auto switches without connecting the load. (Refer to Notes on Wiring 4) and 5) on P.413.)

● External Dimensions : JEP0000-A1 / A1L

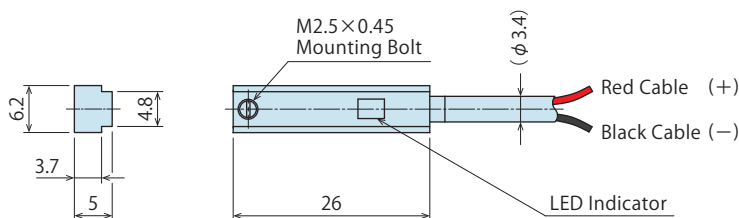

● External Dimensions : JEP0000-A2 / A2L

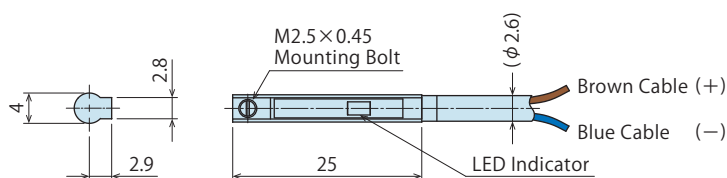

● External Dimensions : JEP0000-A2V / A2VL

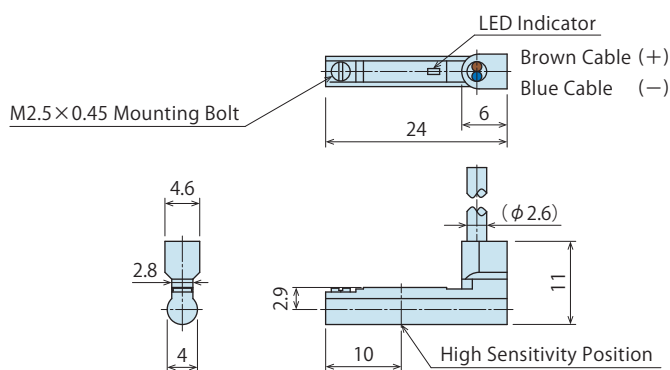

Locating + Clamp

Locating

Hand + Clamp

Support

Valve + Coupler

Cautions + Others

Pallet Gripper

WVA

Locating Pin Clamp

SWP

High-Power Pull Stud Clamp

WPT

JES

FA Pneumatic Hole Clamp

WKH

Lifting Hole Clamp

SWJ

Ball Lock Cylinder

WKA

Pneumatic Robotic Hands

WPW-C

WPS-C

WPA

WPH

WPP

WPQ

Auto Switch Proximity Switch

JEP

High-Power Pneumatic Hole Clamp

SWE

High-Power Pneumatic Swing Clamp

WHE

High-Power Pneumatic Link Clamp

WCE

Pneumatic Hole Clamp

SWA

Pneumatic Swing Clamp

WHA

Double Piston Pneumatic Swing Clamp

WHD

Pneumatic Link Clamp

WCA

Air Flow Control Valve

BZW

Manifold Block

WHZ-MD

● JEP0000-B1 / B1L / B2 / B2L (3-Wire Solid State Auto Switch)

● Specifications

Model No.	JEP0000-B1	JEP0000-B1L	JEP0000-B2	JEP0000-B2L
Name	Solid State Auto Switch			
Wiring Type	3-Wire			
Applicable Load	Relay, Programmable Logic Controller (PLC)			
Output Type	NPN			
Load Voltage / Load Current	Less than DC5 ~ 28V / 50mA			
Internal Voltage Drop	Less than 0.8V			
Leakage Current	Less than 0.1mA			
Current Consumption	Less than 10mA			
Operating Time	Less than 1ms			
Ambient Temperature	-10 ~ 60°C			
Withstand Voltage	AC1500V (There should be no abnormalities in 1 min. application.)			
Insulation Resistance	More than 50MΩ / DC500V (Between the Case and Signal Cable)			
Shock Resistance	30G			
Protection Grade	IP67 (IEC Standard)			
Indicator Light	Red LED illuminates when turned ON			
Electric Cable Length	1m	3m	1m	3m

● Electric Circuit Diagram

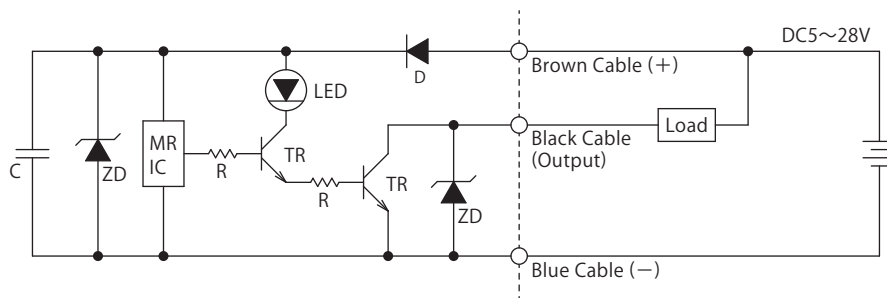

● External Dimensions : JEP0000-B1 / B1L

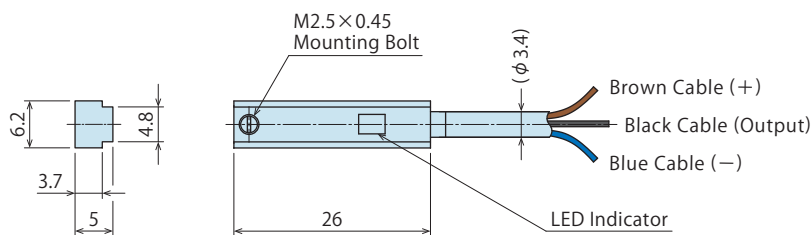

● External Dimensions : JEP0000-B2 / B2L

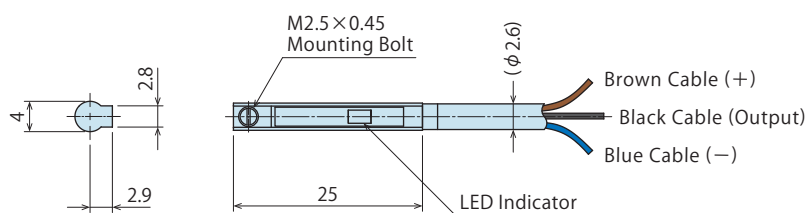

● JEP0000-B3C / B3CL (3-Wire L-Shaped Solid State Auto Switch)

● Specifications

Model No.	JEP0000-B3C	JEP0000-B3CL
Name	Solid State Auto Switch	
Wiring Type	3-Wire	
Applicable Load	Relay, Programmable Logic Controller (PLC)	
Output Type	NPN	
Load Voltage / Load Current	DC5 ~ 28V / 50mA	
Internal Voltage Drop	Less than 0.8V	
Leakage Current	Less than 0.1mA	
Current Consumption	Less than 10 mA	
Operating Time	Less than 1ms	
Ambient Temperature	-10 ~ 60°C	
Withstand Voltage	AC1500V (There should be no abnormalities in 1 min. application.)	
Insulation Resistance	More than 100MΩ / DC500V (Between the Case and Signal Cable)	
Shock Resistance	30G	
Protection Grade	IP67(IEC Standard)	
Indicator Light	Red LED illuminates when turned ON	
Electric Cable Length	1m	3m

● Electric Circuit Diagram

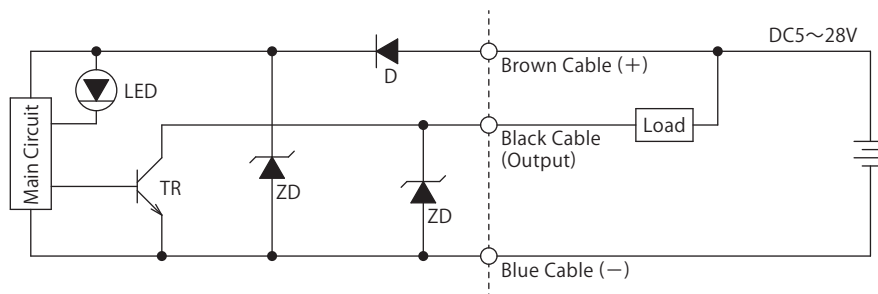

● External Dimensions : JEP0000-B3C / B3CL

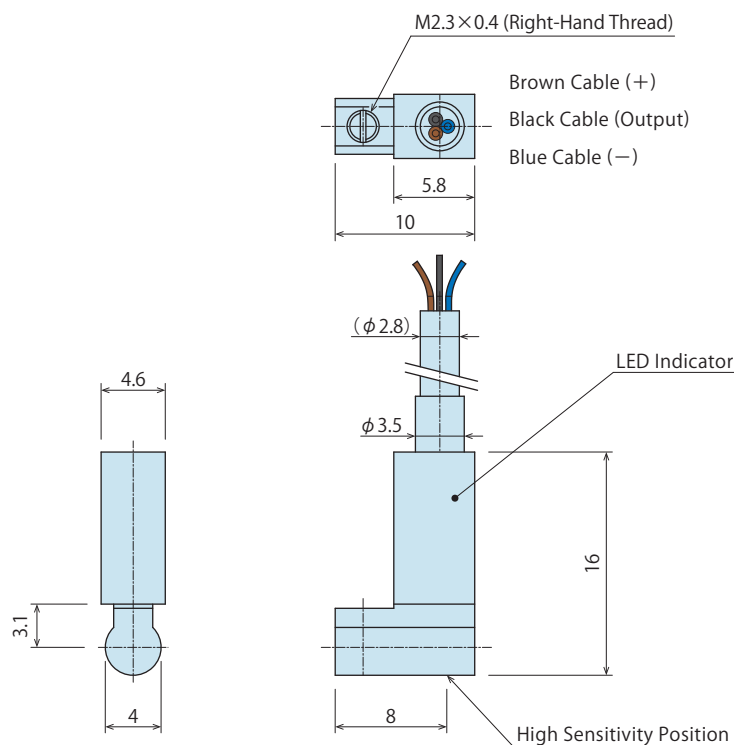

Locating + Clamp

Locating

Hand + Clamp

Support

Valve + Coupler

Cautions + Others

Pallet Gripper

WVA

Locating Pin Clamp

SWP

High-Power Pull Stud Clamp

WPT

JES

FA Pneumatic Hole Clamp

WKH

Lifting Hole Clamp

SWJ

Ball Lock Cylinder

WKA

Pneumatic Robotic Hands

WPW-C

WPS-C

WPA

WPH

WPP

WPQ

Auto Switch Proximity Switch

JEP

High-Power Pneumatic Hole Clamp

SWE

High-Power Pneumatic Swing Clamp

WHE

High-Power Pneumatic Link Clamp

WCE

Pneumatic Hole Clamp

SWA

Pneumatic Swing Clamp

WHA

Double Piston Pneumatic Swing Clamp

WHD

Pneumatic Link Clamp

WCA

Air Flow Control Valve

BZW

Manifold Block

WHZ-MD

● JEP0000-B3B/B3BL (2-Wire L-Shaped Solid State Auto Switch)

● Specifications

Model No.	JEP0000-B3B	JEP0000-B3BL
Name	Solid State Auto Switch	
Wiring Type	2-Wire	
Applicable Load	Relay, Programmable Logic Controller (PLC)	
Load Voltage / Load Current	Less than DC10~28V / 50mA	
Internal Voltage Drop	Less than 5V	
Leakage Current	Less than 1mA	
Current Consumption	Less than 10 mA	
Operating Time	Less than 1ms	
Ambient Temperature	-10~60°C	
Withstand Voltage	AC1500V (There should be no abnormalities in 1 min. application.)	
Insulation Resistance	More than 50MΩ / DC500V (Between the Case and Signal Cable)	
Shock Resistance	30G	
Protection Grade	IP67 (IEC Standard)	
Indicator Light	Red LED illuminates when turned ON	
Electric Cable Length	1m	3m

● Electric Circuit Diagram

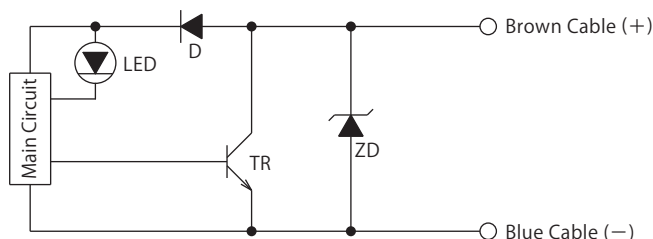

Note :
 1. Auto switch will instantly break due to over loading current if turning on the auto switches without connecting the load.
 (Refer to Notes on Wiring 4) and 5) on P.413.)

● External Dimensions : JEP0000-B3B/B3BL

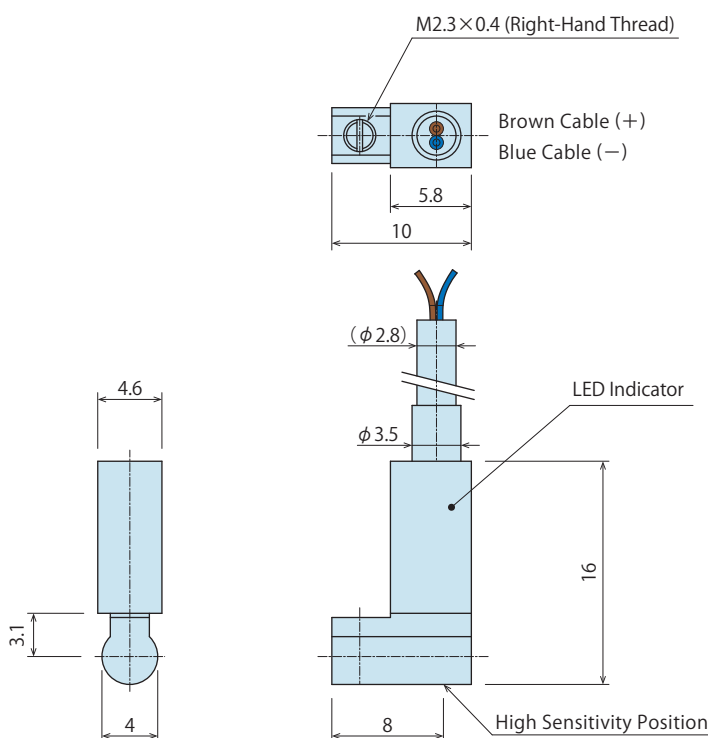

● JEP0000-P / P2 (3-Wire Proximity Switch for Gripping Detection)

● Specifications

Model No.	JEP0000-P	JEP0000-P2
Name	Proximity Switch for Gripping Detection	
Wiring Type	3-Wire	
Output Type	NPN	
Moving Distance	1mm ± 10%	
Voltage Range	DC10 ~ 30V	
Opening / Closing Voltage	Less than 200mA	
Current Consumption	Less than 10mA	
Response Frequency	800Hz	
Ambient Temperature	-25 ~ 70°C	
Withstand Voltage	AC2000V (There should be no abnormalities in 1 min. application.)	
Protection Grade	IP67 (IEC Standard)	
Indicator Light	Red LED illuminates when turned ON	
Electric Cable Length	2m	

● Electric Circuit Diagram

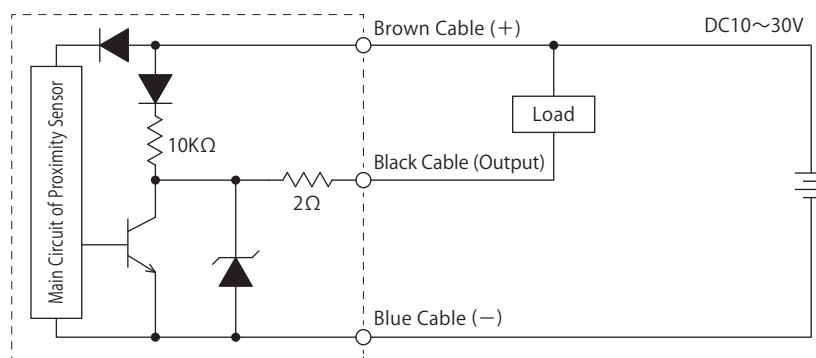

● External Dimensions : JEP0000-P

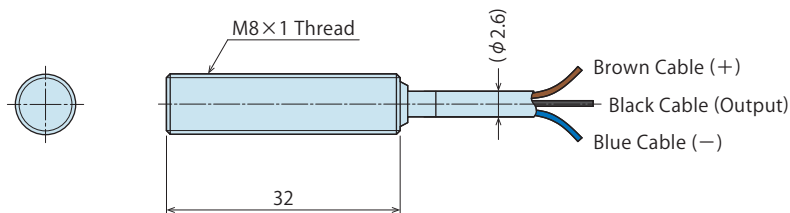

● External Dimensions : JEP0000-P2

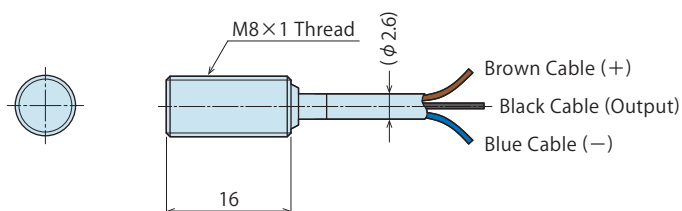

Locating + Clamp

Locating

Hand + Clamp

Support

Valve + Coupler

Cautions + Others

Pallet Gripper

WVA

Locating Pin Clamp

SWP

High-Power Pull Stud Clamp

WPT

JES

FA Pneumatic Hole Clamp

WKH

Lifting Hole Clamp

SWJ

Ball Lock Cylinder

WKA

Pneumatic Robotic Hands

WPW-C

WPS-C

WPA

WPH

WPP

WPK

Auto Switch Proximity Switch

JEP

High-Power Pneumatic Hole Clamp

SWE

High-Power Pneumatic Swing Clamp

WHE

High-Power Pneumatic Link Clamp

WCE

Pneumatic Hole Clamp

SWA

Pneumatic Swing Clamp

WHA

Double Piston Pneumatic Swing Clamp

WHD

Pneumatic Link Clamp

WCA

Air Flow Control Valve

BZW

Manifold Block

WHZ-MD

Cautions

● Notes for Design

- 1) Check the Specifications
 - Please use each product according to the specifications.
The product may be damaged or malfunction if used outside the range of load or specifications.
- 2) Notes on Use in the Interlock Circuit
 - When the auto switch is used for an interlock signal that requires high reliability, please use a double interlock system by providing a mechanical protection function. Or by using another safety switch (sensor) together with the auto switch. Also, please perform periodic maintenance and confirm proper operation.
- 3) Wiring should be prepared as short as possible.
 - For the reed auto switch, if the wiring length to the load is excessively long, inrush current to the auto switch increases and the operational life span will be shortened. (Remains ON)
 - If the wiring length of the solid state auto switch is long, we recommend installing the ferrite core on both ends of the electric cable for noise control.
- 4) Notes when connecting to a load that generates surge voltage.
 - When connecting a load that generates surge voltage such as relay, please use the auto switch equipped with junction protective circuit or use a junction protective element connecting to the auto switch in parallel.
 - If surge voltage is repeatedly generated even with the auto switch equipped with junction protective circuit, it may damage the contact. In this case, please reduce the surge voltage by connecting a surge-absorption element to a surge-generating source (load) in parallel.
- 5) Notes when connecting auto switches in series.
 - Due to voltage drop (refer to internal voltage drop on the specifications) caused by LED, voltage drop of n auto switches connected in series will be multiplied by n times. As a result, in some cases the load will not activate even if the auto switch drives properly.
- 6) Be careful with the polarity when wiring.
 - When connected reversely, the auto switch may malfunction or be damaged.
- 7) When multiple cylinders or robotic hands are placed close together.
 - Please provide enough space when using multiple actuators such as cylinders or robotic hands equipped with auto switches. (If allowable distance of each actuator is specified please follow specified instructions.) If they are too close, auto switches may malfunction due to magnetic interference.
- 8) Secure space for maintenance and inspection
 - Please secure space for maintenance and inspection of auto switches when setting actuators such as cylinders and robotic hands equipped with auto switches.

● Notes on Operating Environment

- 1) Never use the product in an atmosphere with explosive gases.
 - Auto switches are not designed to prevent explosion. Do not use the product in an atmosphere with explosive gases since it may cause serious explosions.
- 2) Do not use the product in an area where a magnetic field is generated.
 - Auto switches may malfunction, or internal magnet actuators, such as cylinders or robotic hands, equipped with auto switches will be demagnetized.
- 3) Do not use the product in an environment where the auto switches are continuously exposed to water or coolant.
 - Although IEC standard IP67 structure is satisfied, please avoid using auto switches in an environment where continuously exposed to water or coolant. This may cause insulation failure or malfunction.
- 4) Do not use the product in an environment with oil or chemicals.
 - If auto switches are used in an environment with coolant or cleaning solvent, even in a short time, they may be adversely affected by improper insulation, malfunction due to swelling of potting resin and/or hardening of electric cable.
- 5) Do not use the product in an environment subject to large temperature cycle.
 - Heat cycles other than ordinary changes in temperature may adversely affect the internal structure of auto switches.
- 6) Avoid accumulation of steel dust and close connection of magnetic materials.
 - An amount of steel chips or steel dusts, such as sputters of welding accumulate around an actuator. Cylinders, robotic hand equipped with auto switches and or magnetic materials (those attracted by magnet) are gathered closely to the actuator. These can weaken internal magnet actuators.
- 7) Do not use the product in an environment with excessive impact.
 - Under the condition of the excessive impact of more than 30G, the contact of the reed auto switch will malfunction and the indicator light may signal or may be disconnected.

● Installation Notes

- 1) Do not drop or bump.
 - Do not drop, bump or apply excessive impact on auto switches. The auto switches may be damaged and cause malfunction.
- 2) Tighten auto switches with appropriate tightening torque.
 - Please follow the tightening torque below. Excessive tightening torque may damage the mounting screw, fitting or main body of the auto switch. Also, mounting position may be shifted due to insufficient tightening torque.

Mounting Screw Size	Tightening Torque (N·m)
M2.3×0.4	0.15
M2.5×0.45	0.25

- 3) Do not carry cylinders or robotic hands by holding the electric cable of the auto switch.
 - It may break the electric cable or damage the internal element.
- 4) Do not fix auto switches with the mounting screws other than attached in main body of the auto switches.
 - Using non-designated screws may damage auto switches.
- 5) Install the auto switches at the center of the operating area.
 - Installation position of auto switches should be adjusted so that a detected object (piston etc.) stops at the center of operating range. (Installation position shown in the catalog shows the most suitable fixed position of stroke end.) Please refer to P.345 for WPS, P.355 for WPA, P.363 for WPH, P.375 for WPP and P.391 for WPQ. If the auto switches are installed at the edge of operating range (near the boundary of ON and OFF), output movement may be unstable.
- 6) Installation position of the auto switches should be adjusted by checking actual operating state.
 - Depending on the installation environment, actuators such as cylinders and robotic hands may not operate properly even if they are installed to the appropriate position. Make sure to check the operating condition even when mounting them at the middle of the stroke.

Locating + Clamp

Locating

Hand + Clamp

Support

Valve + Coupler

Cautions + Others

Pallet Gripper

WVA

Locating Pin Clamp

SWP

High-Power Pull Stud Clamp

WPT

JES

FA Pneumatic Hole Clamp

WKH

Lifting Hole Clamp

SWJ

Ball Lock Cylinder

WKA

Pneumatic Robotic Hands

WPW-C

WPS-C

WPA

WPH

WPP

WPQ

Auto Switch Proximity Switch

JEP

High-Power Pneumatic Hole Clamp

SWE

High-Power Pneumatic Swing Clamp

WHE

High-Power Pneumatic Link Clamp

WCE

Pneumatic Hole Clamp

SWA

Pneumatic Swing Clamp

WHA

Double Piston Pneumatic Swing Clamp

WHD

Pneumatic Link Clamp

WCA

Air Flow Control Valve

BZW

Manifold Block

WHZ-MD

Cautions

● Notes on Wiring

- 1) Check the insulation of wiring.
 - Insulation failure (interference with other circuit, ground fault, and insulation failure between terminals) may send excessive voltage or current to the auto switches causing damage.
- 2) Do not place wires and auto switch cables close to other cables and high voltage cables.
 - Otherwise, surge voltages will be induced creating noise and leading to malfunctions.
- 3) Repeated bending stress or stretching force should be avoided on electric cables.
 - Wiring with bending stress or stretching force repeatedly applied on electric cables will prematurely breakdown.
Bending stress or stretching force applied on the connecting area of electric cables and main body of the auto switches will damage the electric cables.
Auto switches or wires should not be moving especially near the connecting areas.
- 4) Make sure to check the load state (connection and current value) before turning on the power.
 - For 2-Wire Type
Auto switches will instantly break due to over loading current if turning on the auto switches without connecting the load (Shorted Load Circuit). The above statement is also applied to the condition when the brown cable (+, output) of 2-wire type is directly connected to the (+) power terminal of a fixture and etc.
- 5) Avoid shorted load circuit.
 - Reed Auto Switch
Auto switches will instantly break due to over loading current if turning on the auto switch in load short circuit condition.
 - Solid State Auto Switch
Be aware of auto switch breakages when products with PNP output is not equipped with short-circuit protection.
- 6) Avoid wrong wiring
 - Reed Auto Switch
The electric circuit has polarities. The reed switch can operate even with reversed connection, but LED light will not illuminate. Also, flowing excessive current will damage LED and it will not operate properly.
 - Solid State Auto Switch
In case of 2-wire type, even if connected reversely, the auto switch will not be damaged due to protection circuit, but it is always ON.
If reversely connected under short circuit condition, the auto switch will be damaged.
In case of 3-wire type, even if the connections are reversed (power supply line "+" and "-"), the auto switch will be protected by a protection circuit.
However, if connecting the power supply "+" to the blue cable and "-" to the black cable, the auto switch will be damaged.

● Notes on Handling

- 1) It should be operated by qualified personnel.
 - Machines and devices with hydraulic and pneumatic equipment should be operated and maintained by qualified personnel.
- 2) Do not operate or remove the product unless the safety protocols are ensured.
 - ① The machine and equipment can only be inspected or prepared when it is confirmed that the safety devices are in place.
 - ② Before the product is removed, make sure that the above-mentioned safety devices are in place. Shut off the pressure and power source, and make sure no pressure exists in the air and hydraulic circuits.
 - ③ After stopping the product, do not remove until the temperature drops.
 - ④ Make sure there is no trouble/issue in the bolts and respective parts before restarting the machine or equipment.
- 3) Do not disassemble or modify.
 - If the equipment is taken apart or modified, the warranty will be voided even within the warranty period.

● Maintenance • Inspection

Conduct the below maintenances and inspections periodically in order to avoid unintended malfunctions and to ensure the safety.

- 1) Removal of the Product and Shut-off of Pressure Source
 - Before removing the product, make sure that safety devices and preventive devices are in place. Shut off the pressure and power source, and make sure no pressure exists in the air and hydraulic circuits.
 - Make sure there is no trouble/issue in the bolts and respective parts before restarting.
- 2) Never touch terminals while the power is on.
 - It will cause electric shock, malfunction and damage to the auto switches.
- 3) Retightening of Mounting Screws
 - Retighten the screws after adjusting the mounting position when the mounting position of the auto switches is shifted due to the looseness of the mounting screws.
- 4) Check if the electric cable is damaged or not.
 - Damaged cables may cause insulation failure. Exchange the auto switch or repair the reed if there is damage on the electric cable.
- 5) Check the setting position of the detector.
 - Confirm the set position is stopped at the center of the detecting range (the area that red LED illuminates).
- 6) Cleaning Auto Switches
 - The auto switch should be clean. Do not use benzene, paint thinner or alcohol for cleaning. Doing so will cause scratches on the product and indications may be erased. If it is hard to remove stains from the product, wipe it out with a cloth soaked in a neutral detergent diluted with water. Wipe with a dry cloth to remove wet residue.
- 7) Product Storage
 - Keep the product out of direct sunlight in a cool area where it is protected from water and humidity.
- 8) Please contact us for auto switch replacements.

Locating
+
Clamp

Locating

Hand • Clamp

Support

Valve • Coupler

Cautions • Others

Pallet Gripper

WVA

Locating
Pin Clamp

SWP

High-Power
Pull Stud Clamp

WPT

JES

FA Pneumatic
Hole Clamp

WKH

Lifting
Hole Clamp

SWJ

Ball Lock
Cylinder

WKA

Pneumatic
Robotic Hands

WPW-C

WPS-C

WPA

WPH

WPP

WPQ

Auto Switch
Proximity Switch

JEP

High-Power Pneumatic
Hole Clamp

SWE

High-Power Pneumatic
Swing Clamp

WHE

High-Power Pneumatic
Link Clamp

WCE

Pneumatic
Hole Clamp

SWA

Pneumatic
Swing Clamp

WHA

Double Piston
Pneumatic
Swing Clamp

WHD

Pneumatic
Link Clamp

WCA

Air Flow
Control Valve

BZW

Manifold
Block

WHZ-MD

※ Please refer to P.716 for common cautions.

• Warranty

Model No. Indication

JES 000 0 - 02L GN

1 2 3



1 Design No.

0 : Revision Number

2 Shape

02 : Straight (Round Body)

02L : L Shaped (Round Body)

01 : Straight (Rectangular Body)

01L : L Shaped (Rectangular Body)

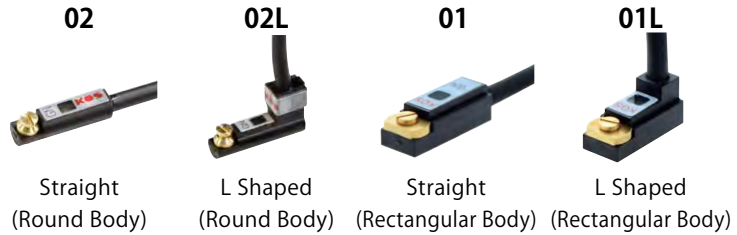

3 Output Format • Detection Polarity

GN : NPN Output N-Pole Sensor (Cable Color:Black) ※1

GS : NPN Output S-Pole Sensor (Cable Color:Gray)

GPN : PNP Output N-Pole Sensor (Cable Color:Black) ※1

GPS : PNP Output S-Pole Sensor (Cable Color:Gray)

※1. The N-pole sensor cannot be used for the models WCC, WFC and WHC (marked with ※2 in the application table).

For detecting both lock and release actions, both the N-pole sensor and the S-pole sensor are required. However, for the models WCC, WFC and WHC (marked with ※2 in the application table), use two S-pole sensors.

Application Table ● = can be installed.

Shape	Round Body	Rectangular Body
Model No.	JES0000-02G□ JES0000-02GP□ JES0000-02LG□ JES0000-02LGP□	JES0000-01G□ JES0000-01GP□ JES0000-01LG□ JES0000-01LGP□
SWJ2000	●	Not Applicable
SWP050□	●	Not Applicable
SWP100□	●	Not Applicable
WCC□	●※2 (S-pole sensor only)	Not Applicable
WCG□-T	●	Not Applicable
WFC□	●※2 (S-pole sensor only)	Not Applicable
WHC□	●※2 (S-pole sensor only)	Not Applicable
WHG□-T	●	Not Applicable
WKH200□	●	Not Applicable
WKK100□	●	Not Applicable
WKK200□	●	Not Applicable
WPA0120	●	Not Applicable
WPA0160	●	Not Applicable
WPA0200	●	Not Applicable
WPA0250	●	Not Applicable
WPB0160	●	Not Applicable
WPB0200	●	Not Applicable
WPB0250	●	Not Applicable
WPE0160	●	Not Applicable
WPE0200	Not Applicable	●
WPE0300	Not Applicable	●
WPE0400	Not Applicable	●
WPE0500	Not Applicable	●
WPE0800	Not Applicable	●

Shape	Round Body	Rectangular Body
Model No.	JES0000-02G□ JES0000-02GP□ JES0000-02LG□ JES0000-02LGP□	JES0000-01G□ JES0000-01GP□ JES0000-01LG□ JES0000-01LGP□
WPF0100	Not Applicable	
WPF0120	●	Not Applicable
WPF0160	●	Not Applicable
WPF0200	Not Applicable	●
WPF0300	Not Applicable	●
WPH0100	●	Not Applicable
WPH0160	●	Not Applicable
WPH0200	Not Applicable	●
WPJ0120	Not Applicable	
WPJ0160	●	Not Applicable
WPJ0200	Not Applicable	●
WPJ0250	Not Applicable	●
WPJ0300	Not Applicable	●
WPJ0400	Not Applicable	●
WPS0160-C	●	Not Applicable
WPS0200-C	●	Not Applicable
WPT□	●	Not Applicable
WPW□-C	●	Not Applicable
WVA□-M	●	Not Applicable
WVB□-M	●	Not Applicable
WVGT□-T	●	Not Applicable

Note: ※2. Please use the S-pole sensor. (N-pole sensor cannot be used.)

Specifications

Model No.	JES0000-02G N S	JES0000-01G N S	JES0000-02GP N S	JES0000-01GP N S
	JES0000-02LG N S	JES0000-01LG N S	JES0000-02LGP N S	JES0000-01LGP N S
Body Shape	Round	Rectangular	Round	Rectangular
Output Specification	NPN (ON when in proximity)		PNP (ON when in proximity)	
Output Current	20mA Max.		80mA Max.	
Current Consumption	8mA Max.		8mA Max.	
Wiring Method	3-Wire			
Applicable Load	Relay, Programmable Logic Controller (PLC)			
Voltage	DC 5 ~ 24V			
Response Speed	16 μsec or less			
Material	Case : GF Reinforced PBT Black Set Screw : Brass			
Indicator Light	Red			
Withstand Voltage	AC1000V (1 minute / Packaged Charging Part / between the Case)			
Insulation Resistance	DC250V (20MΩ or more in Megohms, between the Case)			
Operating Temperature	-20°C ~ +85°C (Make sure no condensation)			
Operating Humidity	20 ~ 95%RH			
Protection Grade	IP67			
Cable Length	1m			

Performance Curve

JES detects only the magnetic force that is vertical to the detection surface. The operating curve is shown below.

Operating point is on the steep part of the operating curve, so even small stroke can be surely detected.

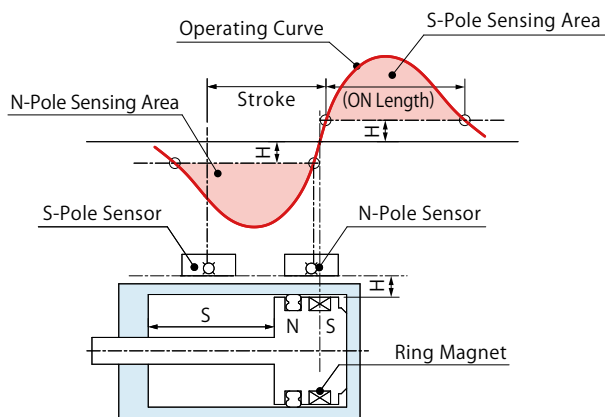

Electric Circuit Diagram

NPN Output

JES0000-02G□、JES0000-02LG□
JES0000-01G□、JES0000-01LG□

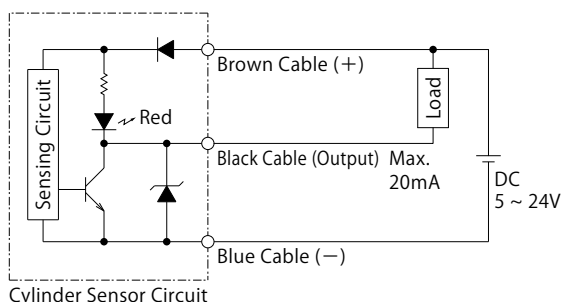

PNP Output

JES0000-02GP□、JES0000-02LGP□
JES0000-01GP□、JES0000-01LGP□

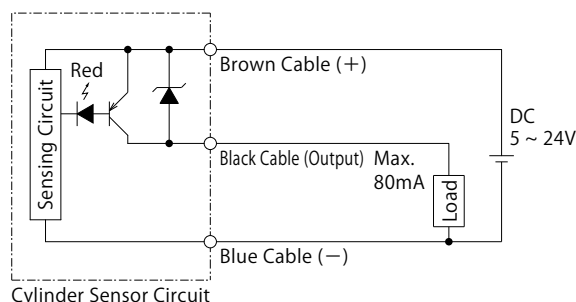

Locating + Clamp

Locating

Hand + Clamp

Support

Valve + Coupler

Cautions + Others

Pallet Gripper

WVA

Locating Pin Clamp

SWP

High-Power Pull Stud Clamp

WPT

JES

FA Pneumatic Hole Clamp

WKH

Lifting Hole Clamp

SWJ

Ball Lock Cylinder

WKA

Pneumatic Robotic Hands

WPW-C

WPS-C

WPA

WPH

WPP

WPQ

Auto Switch Proximity Switch

JEP

High-Power Pneumatic Hole Clamp

SWE

High-Power Pneumatic Swing Clamp

WHE

High-Power Pneumatic Link Clamp

WCE

Pneumatic Hole Clamp

SWA

Pneumatic Swing Clamp

WHA

Double Piston Pneumatic Swing Clamp

WHD

Pneumatic Link Clamp

WCA

Air Flow Control Valve

BZW

Manifold Block

WHZ-MD

External Dimensions

2 Shape 02 : Straight (Round Body)

JES0000-02G□、JES0000-02GP□

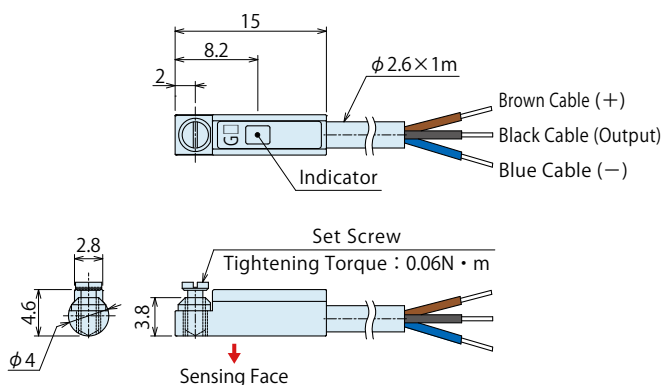

2 Shape 02L : L Shaped (Round Body)

JES0000-02LG□、JES0000-02LGP□

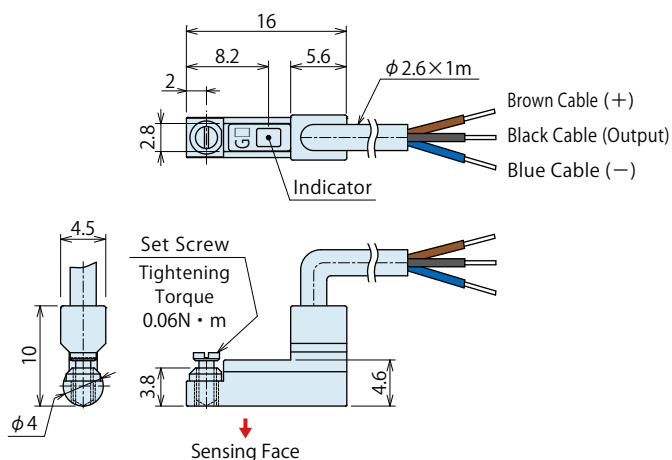

2 Shape 01 : Straight (Rectangular Body)

JES0000-01G□、JES0000-01GP□

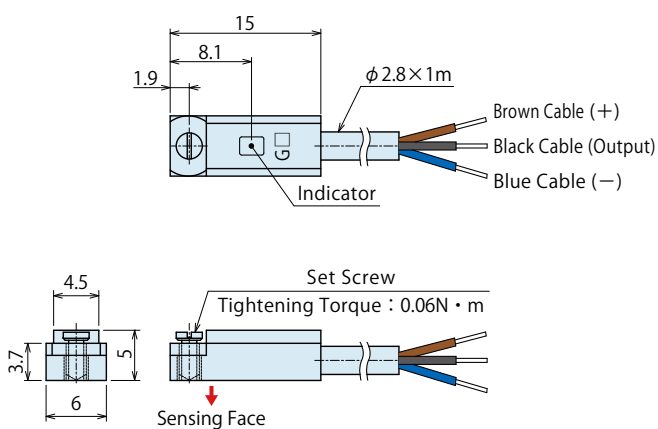

2 Shape 01L : L Shaped (Rectangular Body)

JES0000-01LG□、JES0000-01LGP□

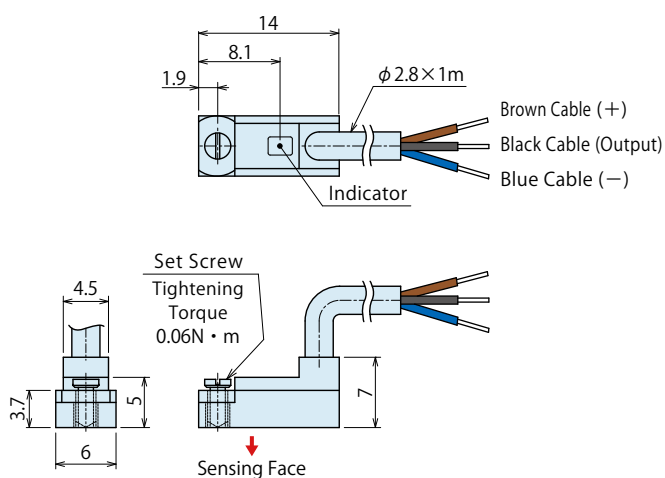

● Cautions

● Notes for Design

- 1) Check the Specifications
 - Please use each product according to the specifications. The product may be damaged or malfunction if used outside the range of load or specifications.
- 2) Notes on Use in the Interlock Circuit
 - When the sensor is used for an interlock signal that requires high reliability, please use a double interlock system by providing a mechanical protection function. Or by using another sensor together with the product. Also, please perform periodic maintenance and confirm proper operation.
- 3) Please avoid using loads that generate surge voltage.
 - If driving a relay, put a Zener diode in parallel for surge protection.

● Notes on Operating Environment

- 1) Never use the product in an atmosphere with explosive gases.
 - Sensor for Air Cylinder is not designed to prevent explosion. Do not use the product in an atmosphere with explosive gases since it may cause serious explosions.
- 2) The product may malfunction if an intense magnetic field is applied to a pole body.
- 3) Make sure to prepare shield measures when using in the following environments.
 - Where large current and/or strong magnetic field are generated.
 - Where noise occurs due to static electricity, etc.
 - Where magnetic powder or dust such as iron powder occurs or scatters.
- 4) Do not use the product in an environment where it is continuously exposed to coolant or chemical liquid.
 - Although IEC standard IP67 structure is satisfied, please avoid using sensors in an environment where continuously exposed to coolant or chemical liquid. This may cause insulation failure or malfunction.
- 5) Do not use the product in an environment with oil or chemicals.
 - If sensors are used in an environment with coolant or cleaning solvent, even in a short time, they may be adversely affected by improper insulation, malfunction due to swelling of potting resin and or hardening of electric cable.
- 6) Do not use the product in an environment with excessive vibrations or impacts.

● Installation Notes

- 1) Electric Wiring Reverse Connection Protection
 - Follow the electric circuit diagram on P.287 and make sure to connect properly. Never connect the power reversely.
- 2) Tighten sensors with appropriate tightening torque.
 - Use the set screw mounted on the sensor body and tighten it with the following torque.
JES0000 : 0.06N · m
- 3) Wiring
 - Do not damage the cables. Damaged, forcibly bended, stretched, winded, load applied or pinched cables will cause fire, electric shock, and/or malfunction due to electric leakage and/or continuity failure.
 - Do not apply excessive stress on the cable port of the sensor.
 - Minimum bending radius of the cable port is R7.
 - If cables are to move, fix the middle of the cables so that no stress is applied to the cable port.
- 4) Mounting position of the sensor should be adjusted by checking actual operating state.

 Locating
+
Clamp

Locating

Hand · Clamp

Support

Valve · Coupler

Cautions · Others

Pallet Gripper

WVA

Locating
Pin Clamp

SWP

High-Power
Pull Stud Clamp

WPT

JES

FA Pneumatic
Hole Clamp

WKH

Lifting
Hole Clamp

SWJ

Ball Lock
Cylinder

WKA

Pneumatic
Robotic Hands

WPW-C

WPS-C

WPA

WPH

WPP

WPQ

Auto Switch
Proximity Switch

JEP

High-Power Pneumatic
Hole Clamp

SWE

High-Power Pneumatic
Swing Clamp

WHE

High-Power Pneumatic
Link Clamp

WCE

Pneumatic
Hole Clamp

SWA

Pneumatic
Swing Clamp

WHA

Double Piston
Pneumatic
Swing Clamp

WHD

Pneumatic
Link Clamp

WCA

Air Flow
Control Valve

BZW

Manifold
Block

WHZ-MD

Cautions

● Notes on Handling

- 1) It should be operated by qualified personnel.
 - The hydraulic and pneumatic equipment should be operated and maintained by qualified personnel.
- 2) Do not operate or remove the product unless the safety protocols are ensured.
 - ① The machine and equipment can only be inspected or prepared when it is confirmed that the safety devices are in place.
 - ② Before the product is removed, make sure that the above-mentioned safety devices are in place. Shut off the pressure and power source, and make sure no pressure exists in the air and hydraulic circuits.
 - ③ After stopping the product, do not remove until the temperature drops.
 - ④ Make sure there is no trouble/issue in the bolts and respective parts before restarting the machine or equipment.
- 3) Do not disassemble or modify.
 - If the equipment is taken apart or modified, the warranty will be voided even within the warranty period.
Never modify the product as it contains a powerful magnet.
- 4) Keep more than one meter away from this product if you have a heart pacemaker, etc. It may be malfunctioned by strong magnetism.
- 5) This sensor is made by ASA Electronics Industry Co. Ltd.
Please contact us or ASA Electronics Industry for further inquiries.

● Maintenance and Inspection

- 1) Removal of the Product and Shut-off of Pressure Source
 - Before removing the product, make sure that safety devices and preventive devices are in place. Shut off the pressure and power source, and make sure no pressure exists in the air and hydraulic circuits.
 - Make sure there is no trouble/issue in the bolts and respective parts before restarting.
- 2) Never touch terminals while the power is on.
 - Otherwise it will cause electric shock, malfunction and damage to the sensor for air cylinder.
- 3) Retightening of Set Screw
 - When mounting position of the sensor for air cylinder is shifted due to looseness of set screw, retighten it after adjusting the mounting position.
- 4) Check if the electric cable is damaged or not.
 - Damaged cables may cause insulation failure.
Replace a sensor for air cylinder or repair the reed if the electric cable is damaged.
- 5) Product Storage
 - The products should be stored in the cool and dark place without direct sunshine or moisture.

MEMO

 Locating
+
Clamp

Locating

Hand • Clamp

Support

Valve • Coupler

Cautions • Others

Pallet Gripper

WVA

Locating
Pin Clamp

SWP

**High-Power
Pull Stud Clamp****WPT****JES**FA Pneumatic
Hole Clamp

WKH

Lifting
Hole Clamp

SWJ

Ball Lock
Cylinder

WKA

Pneumatic
Robotic Hands

WPW-C

WPS-C

WPA

WPH

WPP

WPQ

Auto Switch
Proximity Switch

JEP

High-Power Pneumatic
Hole Clamp

SWE

High-Power Pneumatic
Swing Clamp

WHE

High-Power Pneumatic
Link Clamp

WCE

Pneumatic
Hole Clamp

SWA

Pneumatic
Swing Clamp

WHA

Double Piston
Pneumatic
Swing Clamp

WHD

Pneumatic
Link Clamp

WCA

Air Flow
Control Valve

BZW

Manifold
Block

WHZ-MD

※ Please refer to P.716 for common cautions.

• Warranty

● Cautions

● Notes on Handling

- 1) It should be operated by qualified personnel.
 - The hydraulic machine and air compressor should be operated and maintained by qualified personnel.
- 2) Do not operate or remove the product unless the safety protocols are ensured.
 - ① The machine and equipment can only be inspected or prepared when it is confirmed that the safety devices are in place.
 - ② Before the product is removed, make sure that the above-mentioned safety devices are in place. Shut off the pressure and power source, and make sure no pressure exists in the air and hydraulic circuits.
 - ③ After stopping the product, do not remove until the temperature drops.
 - ④ Make sure there is no trouble/issue in the bolts and respective parts before restarting the machine or equipment.
- 3) Do not touch a clamp (cylinder) while it is working. Otherwise, your hands may be injured.

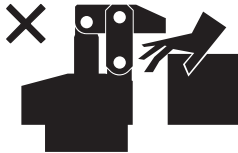

- 4) Do not disassemble or modify.
 - If the equipment is taken apart or modified, the warranty will be voided even within the warranty period.

● Maintenance and Inspection

- 1) Removal of the Machine and Shut-off of Pressure Source
 - Before removing the product, make sure that the safety devices are in place. Shut off the pressure and power source and make sure no pressure exists in the air and hydraulic circuits.
 - Make sure there is no trouble/issue in the bolts and respective parts before restarting.
- 2) Regularly clean the area around the piston rod and plunger.
 - If it is used when the surface is contaminated with dirt, it may lead to packing seal damage, malfunctioning, fluid leakage.

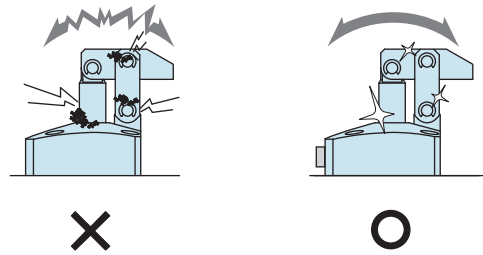

- 3) Regularly clean the reference surfaces (taper reference surface and seating surface) of locating products (SWT/SWQ/SWP/VRA/VRC/VX/VXE/VXF/WVS/VWH/VWM/VWK).
 - Locating products (except VRA/VRC/VX/VXE/VXF and SWR without air blow port) can remove contaminants with the cleaning function. When installing a workpiece or a pallet, make sure there are no contaminants such as thick sludge.
 - Continuous use with dirt on components will lead to locating failure, fluid leakage and malfunction.

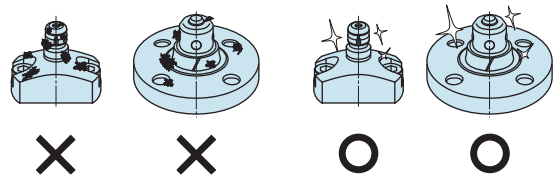

- 4) Regularly tighten pipe, mounting bolt, nut, snap ring, cylinder and others to ensure proper use.
- 5) Make sure the hydraulic fluid has not deteriorated.
- 6) Make sure there is a smooth action without an irregular noise.
 - Especially when it is restarted after left unused for a long period, make sure it can be operated correctly.
- 7) The products should be stored in the cool and dark place without direct sunshine or moisture.
- 8) Please contact us for overhaul and repair.

● Warranty

1) Warranty Period

- The product warranty period is 18 months from shipment from our factory or 12 months from initial use, whichever is earlier.

2) Warranty Scope

- If the product is damaged or malfunctions during the warranty period due to faulty design, materials or workmanship, we will replace or repair the defective part at our expense.

Defects or failures caused by the following are not covered.

- ① If the stipulated maintenance and inspection are not carried out.
- ② Failure caused by the use of the non-confirming state at the user's discretion.
- ③ If it is used or operated in an inappropriate way by the operator. (Including damage caused by the misconduct of the third party.)
- ④ If the defect is caused by reasons other than our responsibility.
- ⑤ If repair or modifications are carried out by anyone other than Kosmek, or without our approval and confirmation, it will void warranty.
- ⑥ Other caused by natural disasters or calamities not attributable to our company.
- ⑦ Parts or replacement expenses due to parts consumption and deterioration. (Such as rubber, plastic, seal material and some electric components.)

Damages excluding from direct result of a product defect shall be excluded from the warranty.

Locating
+
Clamp

Locating

Hand · Clamp

Support

Valve · Coupler

Cautions · Others

Cautions

Installation Notes

Maintenance/
Inspection

Warranty

Company Profile

Company Profile

Our Products

History

Index

Search by
Alphabetical Order

Sales Offices

Sales Offices

Sales Offices across the World

Japan	KOSMEK LTD. HEAD OFFICE	TEL. +81-78-991-5162 FAX. +81-78-991-8787 1-5, 2-chome, Murotani, Nishi-ku, Kobe-city, Hyogo, Japan 651-2241
USA	KOSMEK (USA) LTD. Overseas Subsidiary	TEL. +1-630-620-7650 FAX. +1-630-620-9015 650 Springer Drive, Lombard, IL 60148 USA
	KOSMEK USA ATLANTA BRANCH OFFICE	TEL. +1-630-620-7650 303 Perimeter Center North, Suite 300, Atlanta, GA 30346 USA
Mexico	KOSMEK USA MEXICO BRANCH OFFICE	TEL. +52-442-851-1377 Av. Loma Pinal de Amoles 320-piso PH oficina 504 interior 13, Vista Dorada, 76060 Santiago de Querétaro, Qro. Mexico
Europe	KOSMEK EUROPE GmbH Overseas Subsidiary	TEL. +43-463-287587 FAX. +43-463-287587-20 Schleppeplatz 2 9020 Klagenfurt am Wörthersee Austria
China	KOSMEK (CHINA) LTD. Overseas Subsidiary	TEL.+86-21-54253000 FAX. +86-21-54253709 Room601, RIVERSIDE PYRAMID No.55, Lane21, Pusan Rd, Pudong Shanghai China
	KOSMEK (CHINA) LTD. Dongguan Office Overseas Subsidiary (Sales Office)	TEL.+86-769-85300880 Room 603, Xinchuang Power Building (No. 122-1 West Houjie Avenue), Houjie Town, Dongguan City, Guangdong Province, China
	KOSMEK (CHINA) LTD. Wuhan Office Overseas Subsidiary (Sales Office)	TEL.+86-15802172393 Room 309, Chuanggu Technology Building, 266 Taizihu Rd, Zhuankou Subdistrict, Caidian District, Wuhan 430056, Hubei Province, China
India	KOSMEK LTD. - INDIA Branch	TEL. +91-9880561695 4A/Old No:649, Ground Floor, 4th D cross, MM Layout, Kavalbyrasandra, RT Nagar, Bangalore -560032 India
Thailand	KOSMEK Thailand Representative Office Representative Office	TEL. +66(0)2-059-2010 No.139, Blue Chips Building, 4th Floor, Room No.422, Soi Sukhumvit 63 (Thong Lor 10), Sukhumvit Road, Khlong Tan Nuea, Wattana, Bangkok 10110, Thailand
Taiwan	FULL LIFE TRADING CO., LTD. Distributor	TEL. +886-2-82261860 FAX. +886-2-82261890 16F-4, No.2, Jian Ba Rd., Zhonghe District, New Taipei City Taiwan 23511
Philippines	G.E.T. Inc, Phil. Distributor	TEL.+63-2-310-7286 FAX. +63-2-310-7286 Victoria Wave Special Economic Zone Mt. Apo Building, Brgy. 186, North Caloocan City, Metro Manila, Philippines 1427
Indonesia	PT. Yamata Machinery Sales Distributor	TEL. +62-21-29628607 FAX. +62-21-29628608 Delta Commercial Park I, Jl. Kenari Raya B-08, Desa Jayamukti Kec. Cikarang Pusat Kab. Bekasi 17530 Indonesia

Sales Offices in Japan

Head Office Osaka Sales Office Overseas Sales	TEL. 078-991-5162 FAX. 078-991-8787 1-5, 2-chome, Murotani, Nishi-ku, Kobe-city, Hyogo, 651-2241, Japan
Tokyo Sales Office	TEL. 048-652-8839 FAX. 048-652-8828 81, 4-chome, Onari-cho, Kita-ku, Saitama City, Saitama, 331-0815, Japan
Nagoya Sales Office	TEL. 0566-74-8778 FAX. 0566-74-8808 10-1, 2-chome, Misono-cho, Anjo City, Aichi, 446-0076, Japan
Fukuoka Sales Office	TEL. 092-433-0424 FAX. 092-433-0426 8-10-101, 1-chome, Kamimuta, Hakata-ku, Fukuoka City, Fukuoka, 812-0006, Japan

Global Network

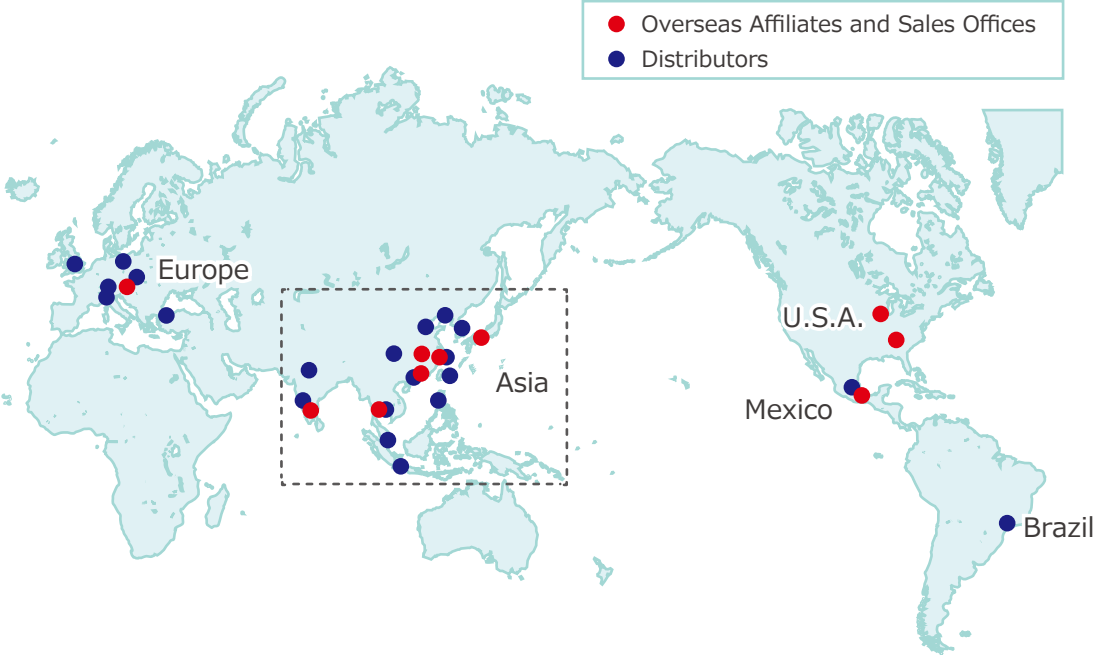

Asia Detailed Map



● FOR FURTHER INFORMATION ON UNLISTED SPECIFICATIONS AND SIZES, PLEASE CALL US.
 ● SPECIFICATIONS IN THIS CATALOG ARE SUBJECT TO CHANGE WITHOUT NOTICE.

