

High-Power Pneumatic Hole Clamp

Model SWE



By expansion of gripper, pull and clamp in workpiece hole
High clamping force which replaces hydraulics

PAT.

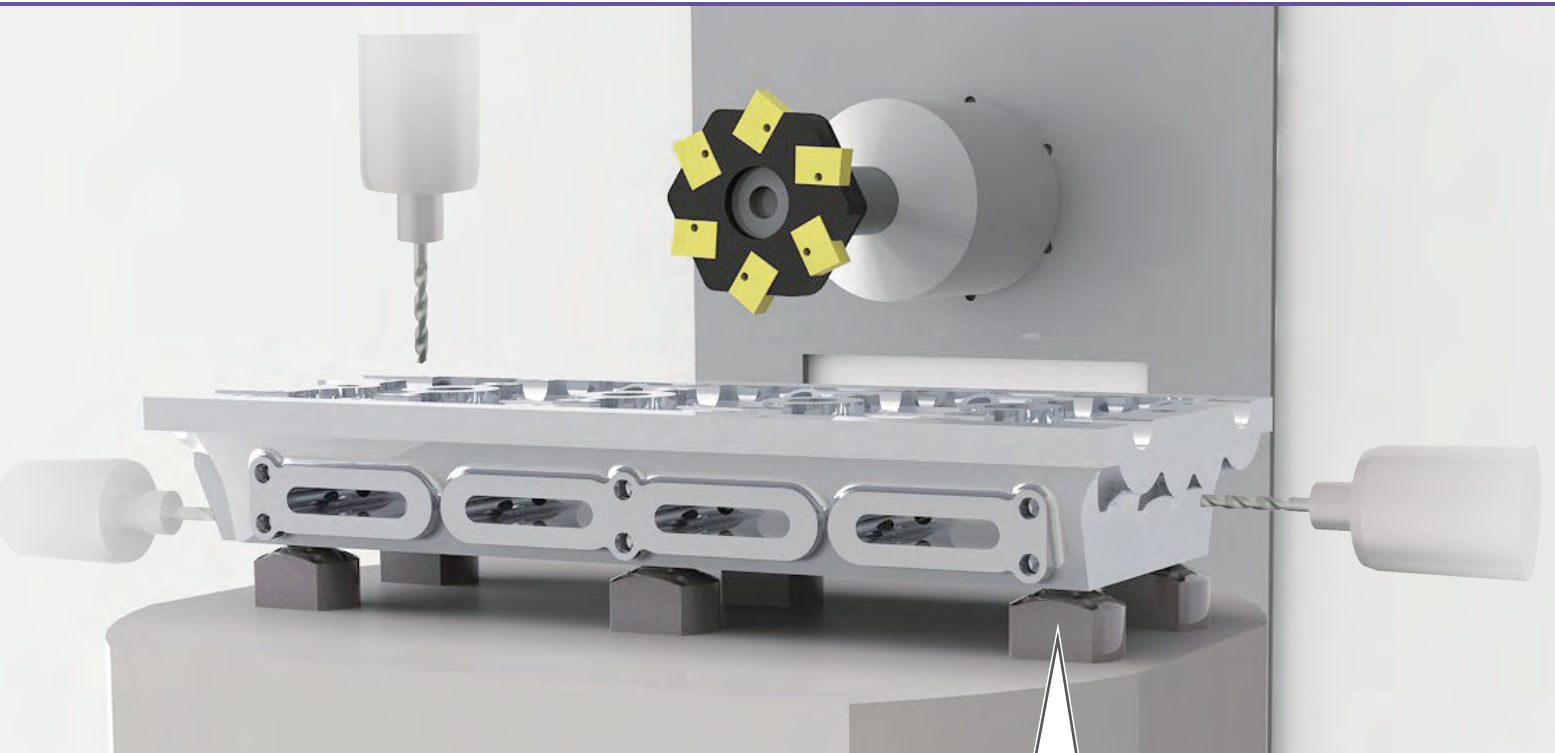

Gripper expands and pulls workpiece down.

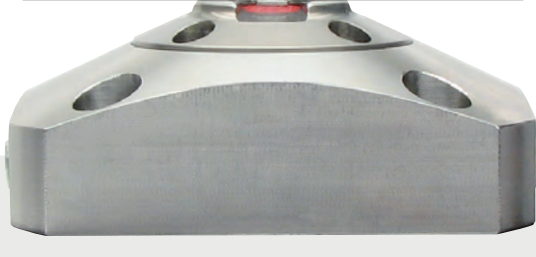
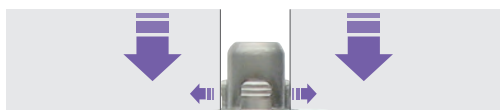

SWE2000

Clamping Force

2 kN

Supplying
Air Pressure

0.45 MPa

Advantages

High-Power Series

Pneumatic Series

Hydraulic Series

Valve / Coupler Hydraulic Unit

Manual Operation Accessories

Cautions / Others

High-Power Hydraulic Swing Clamp

LHE

High-Power Hydraulic Link Clamp

LKE

High-Power Pneumatic Hole Clamp

SWE

High-Power Pneumatic Swing Clamp

WHE

High-Power Pneumatic Link Clamp

WCE

High-Power Pneumatic Work Support

WNC

Rodless Hollow Pneumatic Work Support

WNA

High-Power Pneumatic Pallet Clamp

WVS

• To Workpiece

- Zero interference with 5 faces except clamping face.
- Possible to use standard length tool which provides for better precision.
- Possible to enhance cutting parameters which leads to shorter cycle times.
- Elimination of multiple setups provides better machining process and zero setup time.

• To Machining Equipment

- No hydraulic equipment required by using high-power pneumatic hole clamp.
- Fixture could be extremely downsized.
- Turn-table could be downsized.
- The movement of tool could be shorten.
- For saving weight of fixture.
- Machining equipment could be more simple.
- Good design for easy flow of chips and reduction in coolant usage.

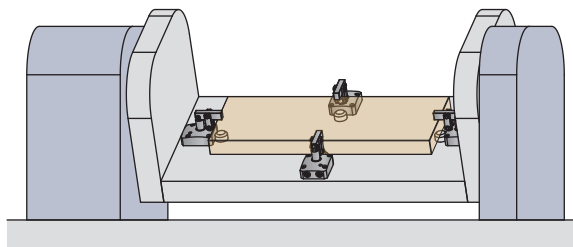

<Before> Clamping around the Workpiece

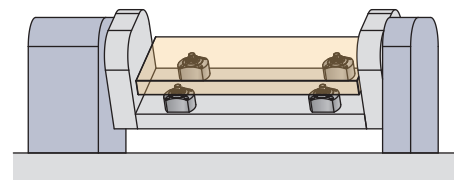

<After> Using the Hole Clamps

• To Machining Line

- 5-face machining makes it possible to put process together.
- Machining line is kept small and simple.
- Possible to enhance cutting parameters which leads to shorter cycle times.

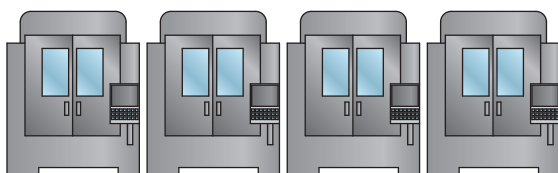

<Before> Large Machining Centers
and Long Machining Lines

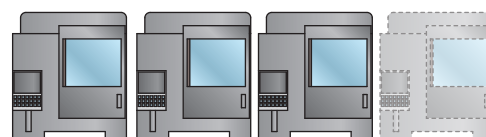

<After> Smaller Machining Centers
and Shorter Machining Lines

● Features

● Variable Mounting Dimensions to Suit the Equipment

Able to design thinner plate since all pipes are set in flange.

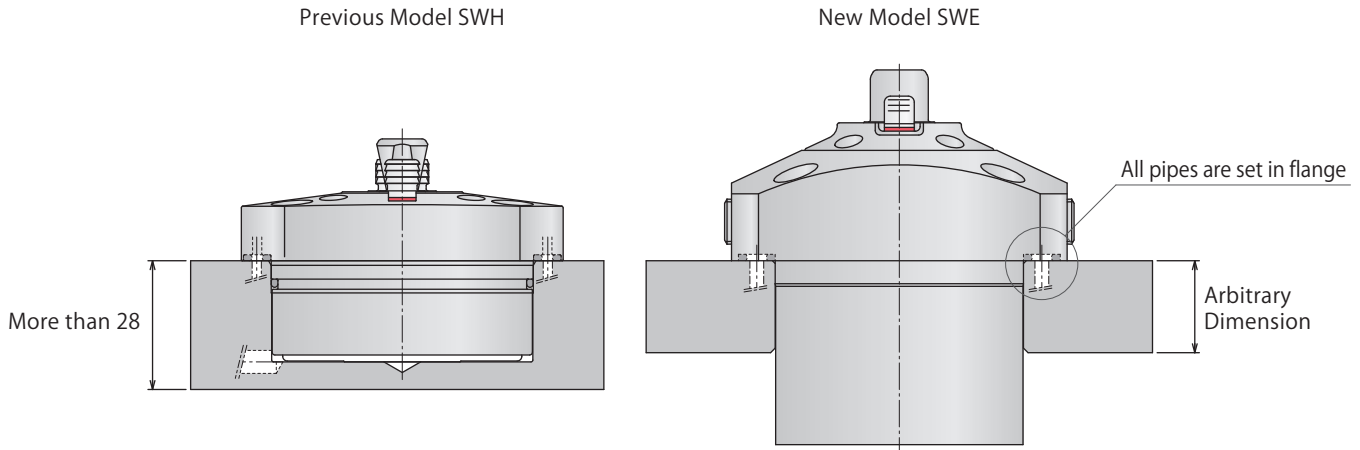

● Seating Surface Height Suitable to Workpiece

Level the height in 5mm increments according to the phase of workpiece seating surface.

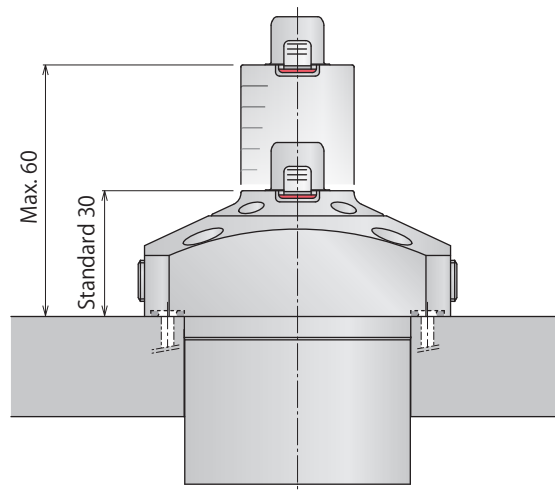

• Hole Diameter to Suit a Variety of Workpieces

In order to suit different hole diameters and tolerances, hole diameters can be specified in 0.5mm increments.

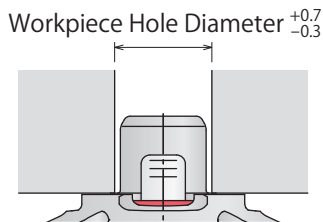

Model No.	Workpiece Hole Diameter (mm)															
	6	6.5	7	7.5	8	8.5	9	9.5	10	10.5	11	11.5	12	12.5	13	
SWE1000	Body size – Type 1															
SWE2000							Body size – Type 2									

• More Powerful Clamping Force with Mechanical Lock

By mechanical lock system clamping force has extremely increased compared to our previous model SWH. SWE is useful for the machining that used to require hydraulic clamping systems.

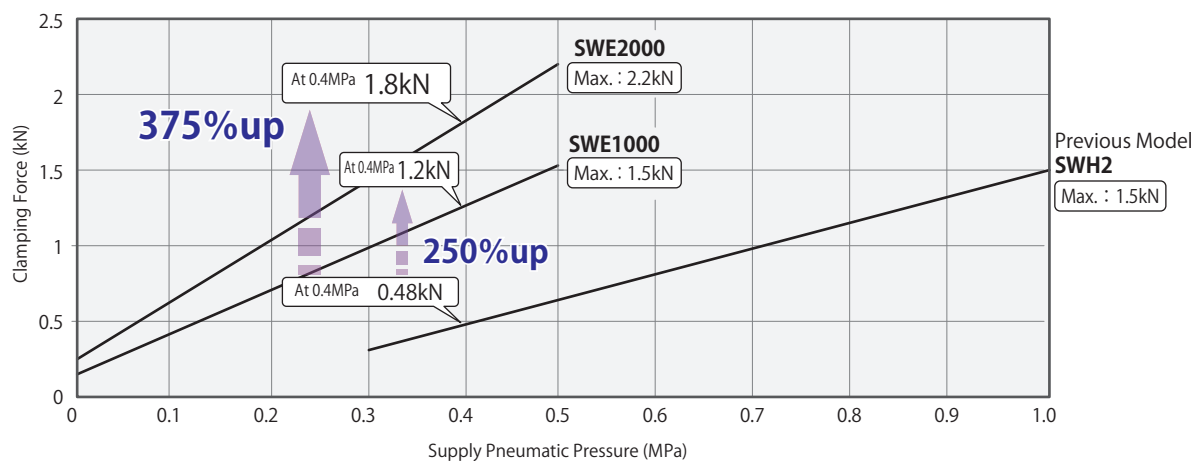

● Features

● Various Kinds of Protection by Cap Structure

※ SWE1000 has no cap structure.

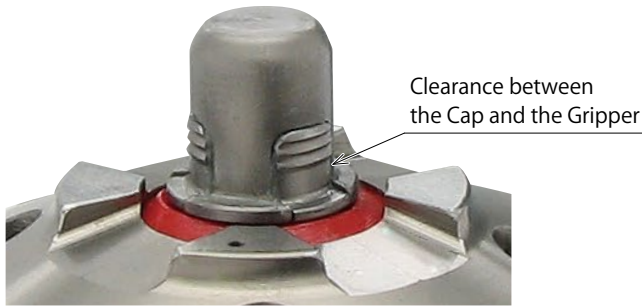

- Minimum clearance between the cap and the gripper prevents cutting chips from entering inside the hole clamp.

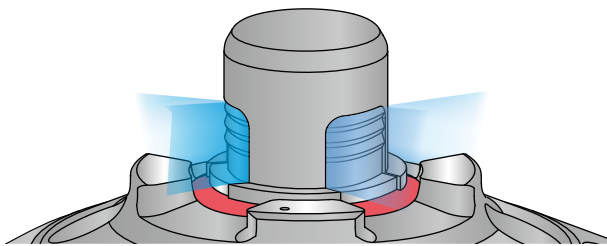

- Small clearance leads to effective purging. Even with a little air flow it prevents coolant from entering inside the hole clamp.

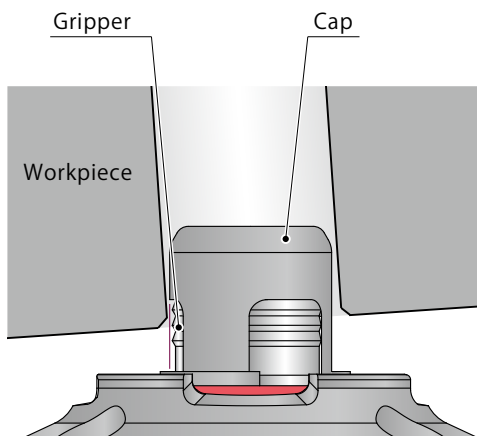

- Workpiece does not have contact with gripper. It makes loading-unloading smooth.

• Pursuing Good Design for Cutting Chips

Having smaller seating surface and wide sweep area on the flange enables easy flow of cutting chips and reduction in coolant usage.

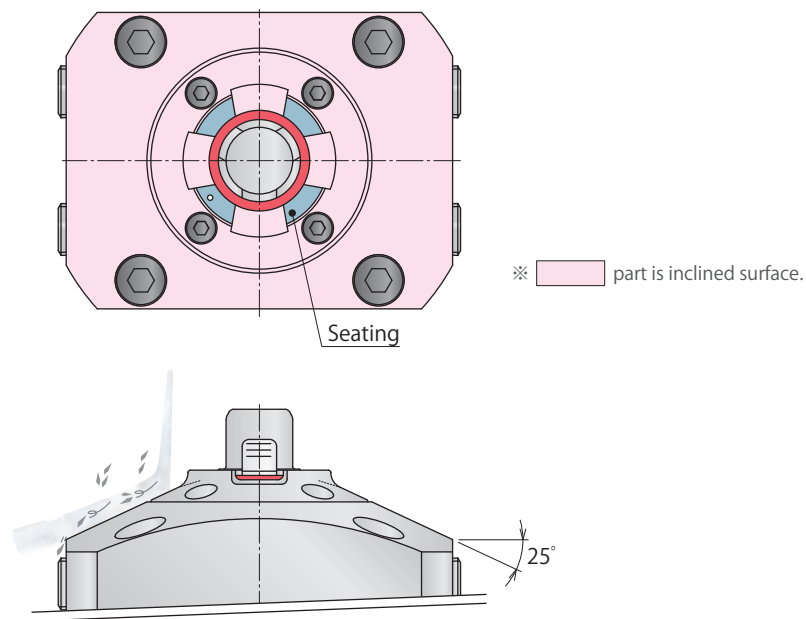

• Secure Clamp Action Out of Sight

Spring for lifting grips a workpiece strongly and pulls it in. Even when air pressure is at zero, self-lock function by spring for locking ensures safety.

※This is a simplified drawing. Actual components are different.

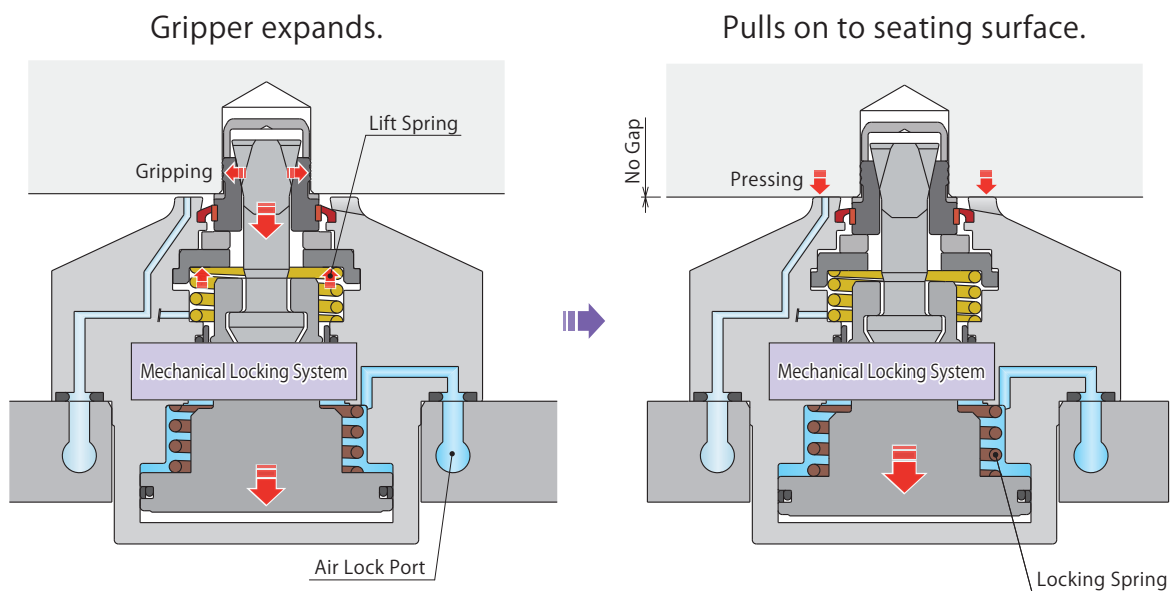

● Features

● Action Confirmation of Clamping

Lift-up function allows to check the movement of pulling and lifting off the workpiece. It can be used in automated line.

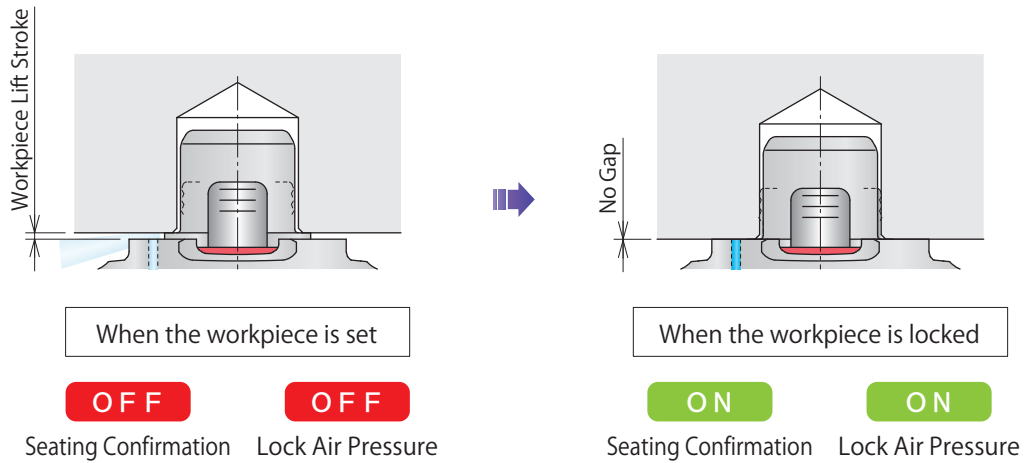

● Abnormality Detection for Unpredictable Troubles

Error detection for unpredictable troubles when processing or transferring. It can be used in automated line.

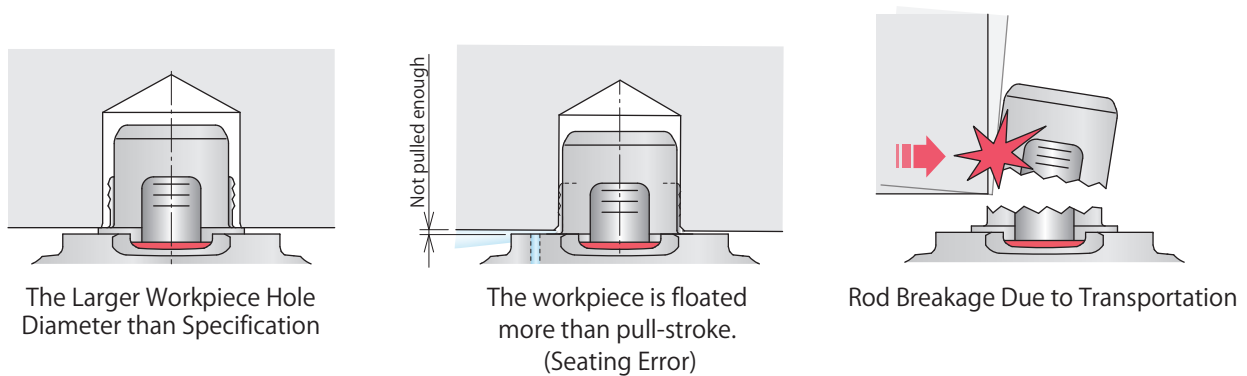

Action Description

※This is a simplified drawing. Actual components are different.

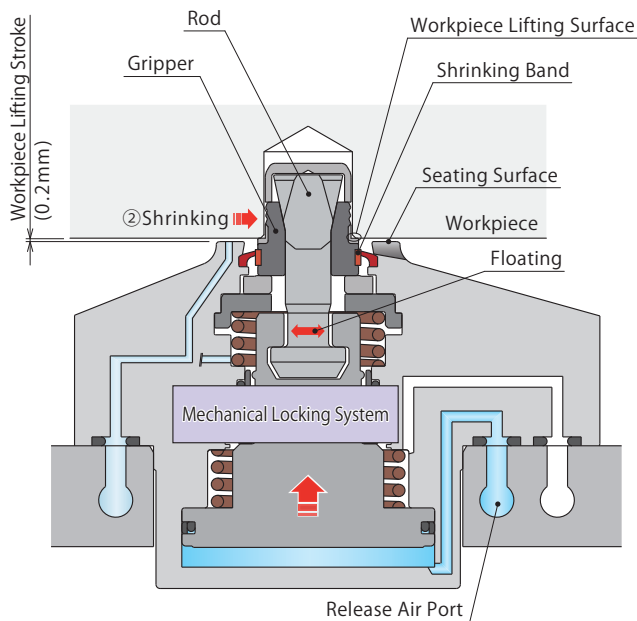

Released State

- ① Air pressure is supplied to the release port.
- ↓
- ② The rod is lifted up and the gripper retracts.
(For workpiece lifting option, there is a gap between workpiece bottom surface and seating surface.)

Air Pressure Switch		Seat Check Detection (Air Sensor)
Release Air Pressure	Lock Air Pressure	
ON	OFF	OFF

※ Continuously supply air pressure to the air blow port and seating confirmation port. If clamps are used without air supply, contaminants enter into clamps resulting in clamping error.

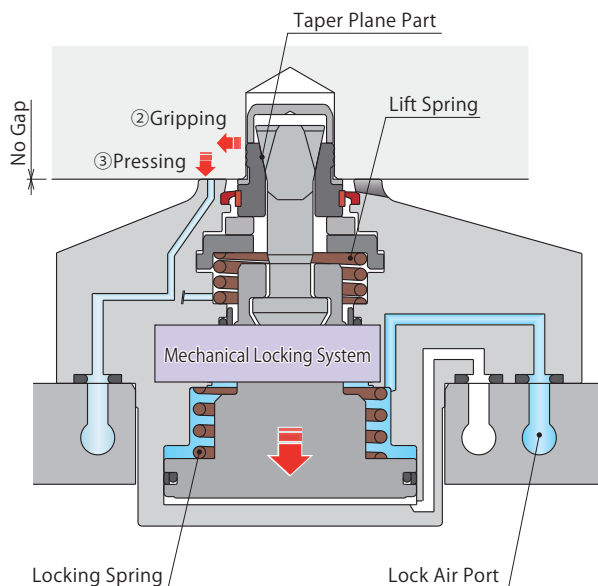

Locked State

- ① Air pressure is supplied to the lock port.
- ↓
- ② The rod descends and the gripper expands along the taper plane. (Since the gripper is lifted by spring force, it does not pull down.)
- ↓
- ③ When pulling force exceeds the spring force for lift up, pulling force works after the gripper digs into workpiece. Then, it presses workpiece onto seating surface. (Clamping force = Pressing force onto seating surface.)

Air Pressure Switch		Seat Check Detection (Air Sensor)
Release Air Pressure	Lock Air Pressure	
OFF	ON	ON

Abnormality Detected State (Clamping without Workpiece)

The built-in check valve function and seating confirmation air pressure detect abnormal condition as follows.

- When clamping workpiece which has larger workpiece hole diameter or clamping without workpiece (In this state the gripper expands but the lifting spring does not have pulling force so the workpiece lifting surface does not descend.)
- When rod or gripper is broken.
- If the piston is fully stroked when it has to stop at the bottom.
- In the case workpiece is floated more than 1mm when setting it.

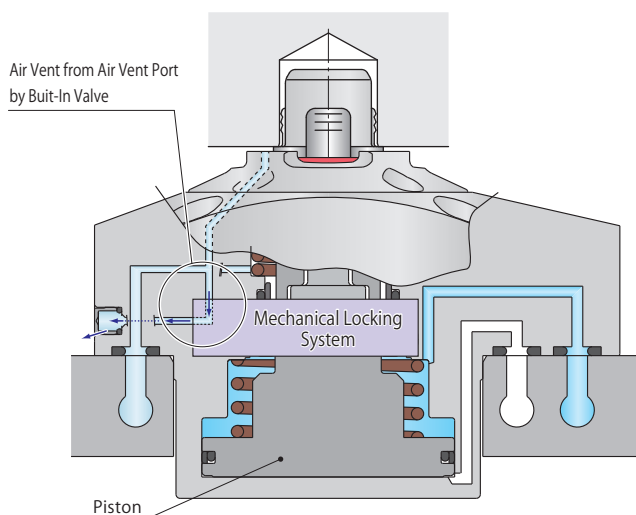

Air Pressure Switch		Seat Check Detection (Air Sensor)
Release Air Pressure	Lock Air Pressure	
OFF	ON	OFF

High-Power Series

Pneumatic Series

Hydraulic Series

Valve / Coupler Hydraulic Unit

Manual Operation Accessories

Cautions / Others

High-Power Hydraulic Swing Clamp

LHE

High-Power Hydraulic Link Clamp

LKE

High-Power Pneumatic Hole Clamp

SWE

High-Power Pneumatic Swing Clamp

WHE

High-Power Pneumatic Link Clamp

WCE

High-Power Pneumatic Work Support

WNC

Rodless Hollow Pneumatic Work Support

WNA

High-Power Pneumatic Pallet Clamp

WVS

Model No. Indication (Workpiece Hole Shape : Straight)

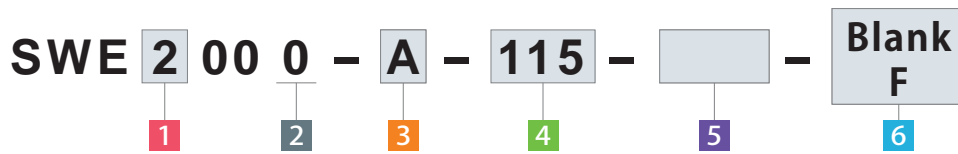

1 Body Size ※ Please refer to specifications, performance curve and external dimensions for details.

- 1 : Available in workpiece hole diameters between $\phi 6$ and $\phi 9$ (No cap)
- 2 : Available in workpiece hole diameters between $\phi 9$ and $\phi 13$ (With cap)

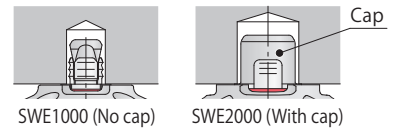

2 Design No.

0 : Revision Number

3 Workpiece Lifting Option

- A : With Lifting Function (Workpiece Lifting Option)
- N : Without Lifting Function

The lifting function lifts the workpiece 0.2mm up from the seating surface when the clamp is released.

Note : When using SWE with expansion locating pin(s) (model VWH, VWM, VWK, VFH, VFL, VFM, VFJ, VFK, VX), please choose **N** : Without Lifting Function.

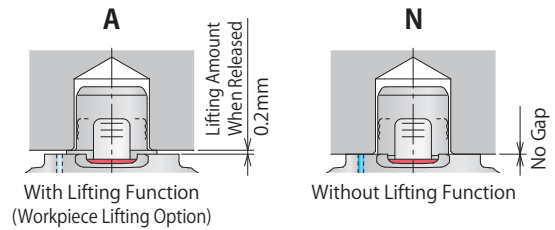

4 Workpiece Hole Diameter (Workpiece Hole Code)

Workpiece Hole Code : Workpiece Hole Diameter $\phi d \begin{smallmatrix} +0.7 \\ -0.3 \end{smallmatrix}$

※ Workpiece hole diameter should be specified in 0.5mm increments from the allowable range in the following table.

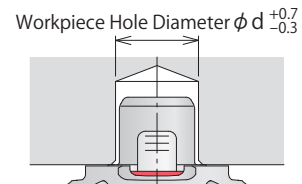

Workpiece Hole Code	060	065	070	075	080	085	090	095	100	105	110	115	120	125	130	
Workpiece Hole Diameter $\phi d \begin{smallmatrix} +0.7 \\ -0.3 \end{smallmatrix}$ (mm)	6	6.5	7	7.5	8	8.5	9	9.5	10	10.5	11	11.5	12	12.5	13	
SWE1000 No Cap	Allowable Range															
SWE2000 With Cap							Allowable Range									

5 Seating Height Dimension

Blank : Standard Height (30mm)

H Seating Height : Specifying Seating Height (In 5mm increments)

Model	Seating Height H (mm)								
	Standard	30	35	40	45	50	55	60	
SWE1000	30	★	H Range						
SWE2000	30	★	H Range						

※ ★ part is standard height, and seating height dimension code is "Blank".

※ Entry example when specifying non-standard seating height.

Seating Height 50mm : **H50**

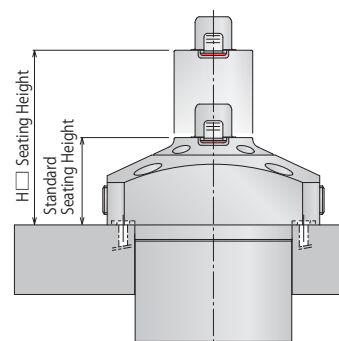

6 Workpiece Hole (Gripper) Shape

Blank : With Serration (Workpiece Hole Shape: Straight)

F : Without Serration (Workpiece Hole Shape: Straight)

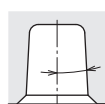
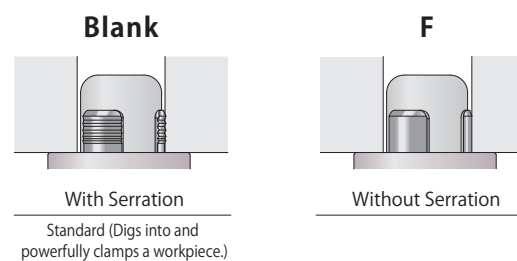

Slope Angle
Less than 3°

Taper Hole

Refer to P.87~P.88 for the taper workpiece hole.

※ Contact us when ordering the taper hole model.

Model No. Indication (Workpiece Hole Shape : Tapered)

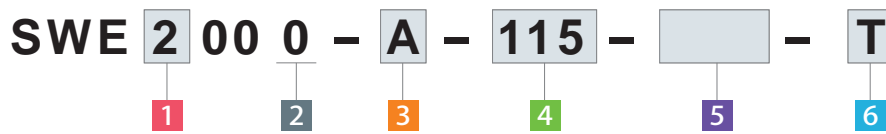

1 Body Size ※ Please refer to specifications, performance curve and external dimensions for details.

- 1 : Available in workpiece hole mouth diameters between $\phi 6.5$ and $\phi 9$ (No cap)
- 2 : Available in workpiece hole mouth diameters between $\phi 9$ and $\phi 13$ (With cap)

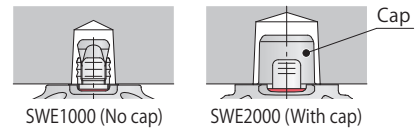

2 Design No.

0 : Revision Number

3 Workpiece Lifting Option

- A : With Lifting Function (Workpiece Lifting Option)
- N : Without Lifting Function

The lifting function lifts the workpiece 0.2mm up from the seating surface when the clamp is released.

Note : When using SWE with expansion locating pin(s) (model VWH, VWM, VWK, VFH, VFL, VFM, VFJ, VFJ, VFJ, VFJ, VFJ, VFJ, VFJ, VFJ), please choose **N** : Without Lifting Function.

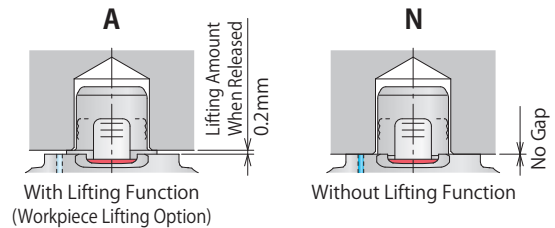

4 Workpiece Hole Mouth Diameter (Workpiece Hole Code)

Workpiece Hole Code : Workpiece Hole Mouth Diameter ϕd

- ※ Workpiece hole mouth diameter ϕd should be specified in 0.5mm increments from the allowable range in the following table.
- ※ The allowable tolerance of the hole mouth diameter ϕd differs depending on the slope angle. Refer to the table below.

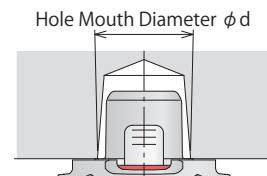

Workpiece Hole Code	(060)	065	070	075	080	085	090	095	100	105	110	115	120	125	130	
Hole Mouth Diam. ϕd (mm)	-	6.5	7	7.5	8	8.5	9	9.5	10	10.5	11	11.5	12	12.5	13	
SWE1000 No Cap		Allowable Range														
SWE2000 With Cap							Allowable Range									

※ Taper hole model is not available for Workpiece Hole Code :060.

Workpiece Hole Slope Angle and Allowable Tolerance of Hole Mouth Diameter

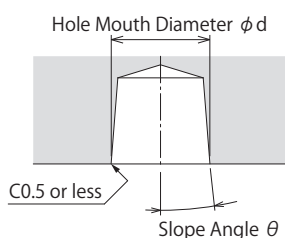

Model No.	Workpiece Hole Code	Slope Angle θ	Allowable Tolerance of Hole Mouth Diam.
SWE1000	065 ~ 090	$1 \leq \theta \leq 2.5$	$\phi d \pm 0.3$
		$2.5 < \theta \leq 3$	$\phi d \begin{smallmatrix} +0.3 \\ -0.15 \end{smallmatrix}$
SWE2000	090	$1 \leq \theta \leq 2$	$\phi d \pm 0.3$
		$2 < \theta \leq 2.5$	$\phi d \begin{smallmatrix} +0.3 \\ -0.15 \end{smallmatrix}$
	095 ~ 130	$2.5 < \theta \leq 3$	$\phi d \begin{smallmatrix} +0.3 \\ 0 \end{smallmatrix}$
		$1 \leq \theta \leq 2.5$	$\phi d \pm 0.3$
		$2.5 < \theta \leq 3$	$\phi d \begin{smallmatrix} +0.3 \\ -0.15 \end{smallmatrix}$

※ Please contact us when the slope angle is less than 1°.

5 Seating Height Dimension

Blank : Standard Height (30mm)

H Seating Height : Specifying Seating Height (In 5mm increments)

Model	Seating Height H (mm)							
	Standard	30	35	40	45	50	55	60
SWE1000	30	★						
SWE2000	30	★						

※ ★ part is standard height, and seating height dimension code is "Blank".

※ Entry example when specifying non-standard seating height.

Seating Height 50mm : **H50**

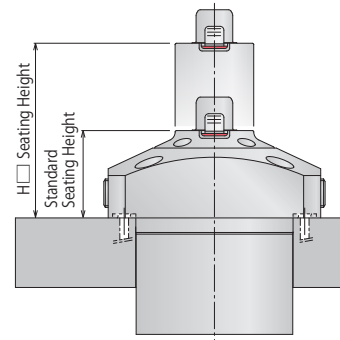

6 Workpiece Hole (Gripper) Shape

T : Taper Hole (with Serration)

When ordering this model, please inform us of the detailed dimensions of the workpiece hole.

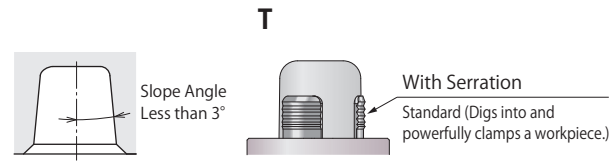

Workpiece Hole Shape : Taper Hole (with Serration)

(‘No Serration’ is not available.)

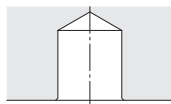

Hole Shape: Straight

Refer to P.85~P.86 for the straight workpiece hole.

Specifications

Model No.		SWE1000-□-□-□ SWE1000-□-□-□- F SWE1000-□-□-□- T	SWE2000-□-□-□ SWE2000-□-□-□- F SWE2000-□-□-□- T															
4 Workpiece Hole Code		060	065	070	075	080	085	090	090	095	100	105	110	115	120	125	130	
Workpiece	6 Blank / F Hole Shape : Straight	Hole Diameter $\phi d \begin{smallmatrix} +0.7 \\ -0.3 \end{smallmatrix}$ mm	6	6.5	7	7.5	8	8.5	9	9	9.5	10	10.5	11	11.5	12	12.5	13
		Hardness	Less than HB250															
	6 T Hole Shape : Taper	Hole Mouth Diameter ϕd mm	-	6.5	7	7.5	8	8.5	9	9	9.5	10	10.5	11	11.5	12	12.5	13
		Allowable Tolerance of Hole Mouth Diam.	Refer to 4 Workpiece Hole Code on P.87.															
		Hole Slope Angle																
		Hardness	Less than HB250															
Allowable Offset (Floating Clearance of Expanding Area) ^{※1} mm		±0.5																
Full Stroke mm		4.2																
Workpiece Pulling Stroke mm		1.0																
Workpiece Lifting Stroke ^{※2} mm		0.2																
Workpiece Lifting Force ^{※2} kN		0.09						0.15										
Cylinder Capacity (Empty Action)	Release Side	18.6						25.5										
	Lock Side	17.6						24.2										
Maximum Operating Pressure MPa		0.5																
Minimum Releasing Pressure MPa		0.2																
Withstanding Pressure MPa		0.75																
Recommended Air Blow Pressure MPa		0.4 ~ 0.5						0.2 ~ 0.3										
Operating Temperature °C		0 ~ 70																
Usable Fluid		Dry Air																
Weight kg		Refer to the External Dimensions																

Notes:

※1. The clamping part is an adjusting structure and the clamping operation is done by locating the workpiece hole. The numerical value in the table shows the amount of tolerance value of single clamp. Please consider the center distance accuracy of each clamping installation part and each workpiece hole when used with other location clamps / location cylinders, or when using more than two of these products.

※2. Workpiece lifting stroke and workpiece lifting force are functions only for lifting option.

Clamping Force Curve

Model No.		6 Blank / T : With Serration		6 F : Without Serration	
		SWE1000-□-□-□ SWE1000-□-□-□- T	SWE2000-□-□-□ SWE2000-□-□-□- T	SWE1000-□-□-□- F	SWE2000-□-□-□- F
Clamping Force kN	Air Pressure 0.5 MPa	1.5	2.2	0.43	0.60
	Air Pressure 0.4 MPa	1.2	1.8	0.35	0.50
	Air Pressure 0.3 MPa	1.0	1.4	0.27	0.40
	Air Pressure 0.2 MPa	0.70	1.0	0.20	0.30
	Air Pressure 0 MPa	0.15	0.25	0.04	0.07
Clamping Force Calculation Formula ^{※3} kN		$F = 2.76 \times P + 0.15$	$F = 3.92 \times P + 0.25$	$F = 0.78 \times P + 0.04$	$F = 1.1 \times P + 0.07$
Max. Operating Pressure MPa		0.5	0.5	0.5	0.5

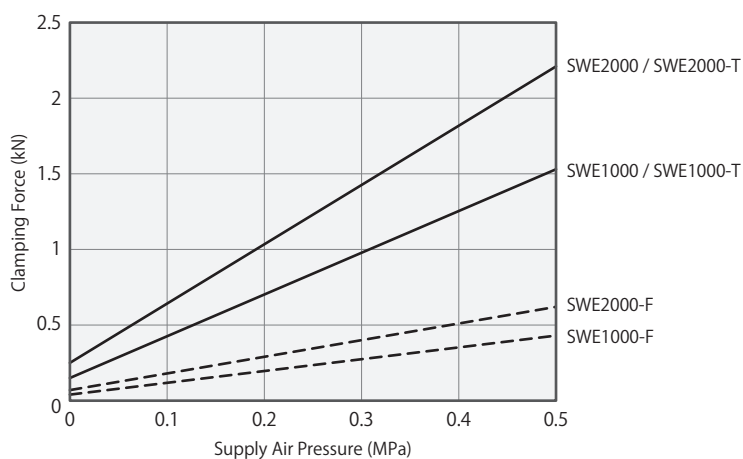

Notes :

1. This graph shows the relationship between clamping force (kN) and supply air pressure (MPa).
2. Clamping force shows pressing force against the seating surface.
3. Workpiece hole that is extremely thin can be deformed by clamping action and the specifications will not be fulfilled.
4. Clamping force of F : Without Serration shows the calculated value when the friction coefficient of workpiece and gripper is $\mu 0.1$.

※3. F: Clamping Force (kN), P : Supply Air Pressure (MPa)

High-Power Series

Pneumatic Series

Hydraulic Series

Valve / Coupler
Hydraulic Unit

Manual Operation
Accessories

Cautions / Others

High-Power Hydraulic
Swing Clamp

LHE

High-Power Hydraulic
Link Clamp

LKE

High-Power Pneumatic
Hole Clamp

SWE

High-Power Pneumatic
Swing Clamp

WHE

High-Power Pneumatic
Link Clamp

WCE

High-Power Pneumatic
Work Support

WNC

Rodless Hollow
Pneumatic Work Support

WNA

High-Power Pneumatic
Pallet Clamp

WVS

External Dimensions

※This drawing shows the released state of SWE1000-A-□.

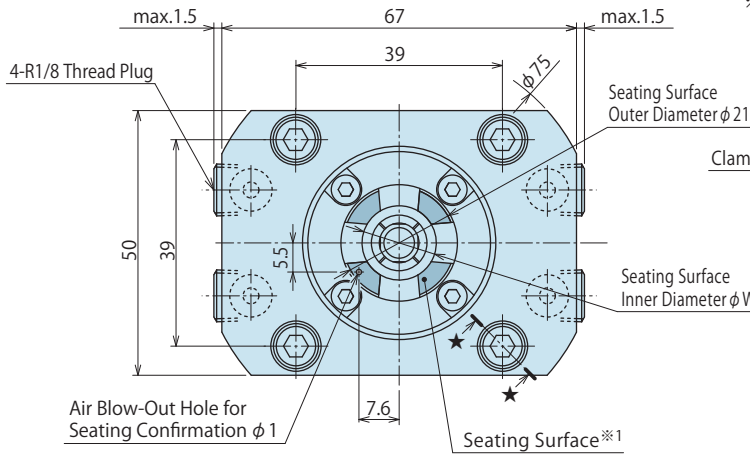

Expanding Area Detail

Workpiece Lifting Stroke ※3

(Clearance from seating surface when released)

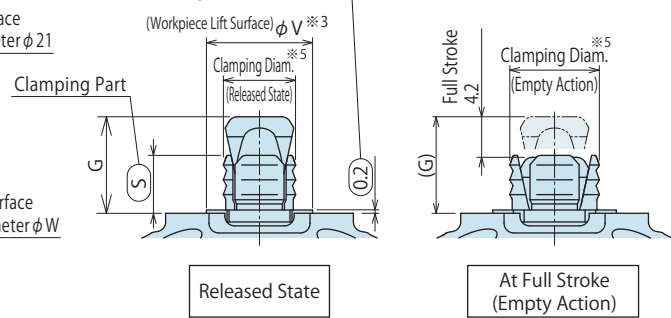

Seating Height: Standard

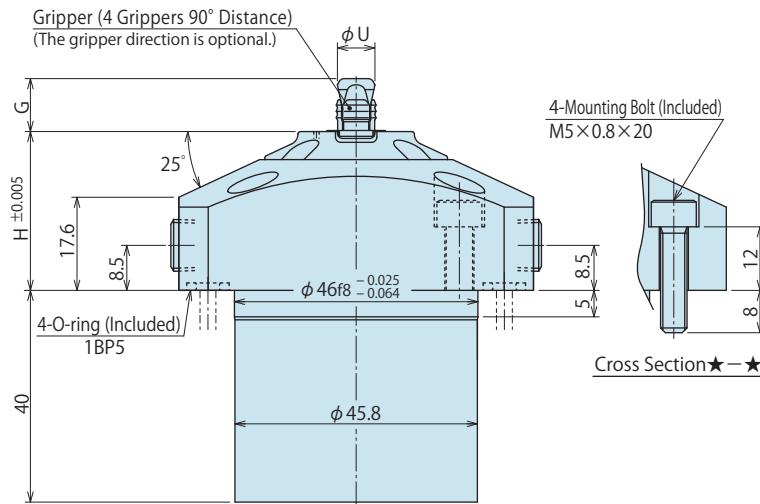

Seating Height: Specified ※4

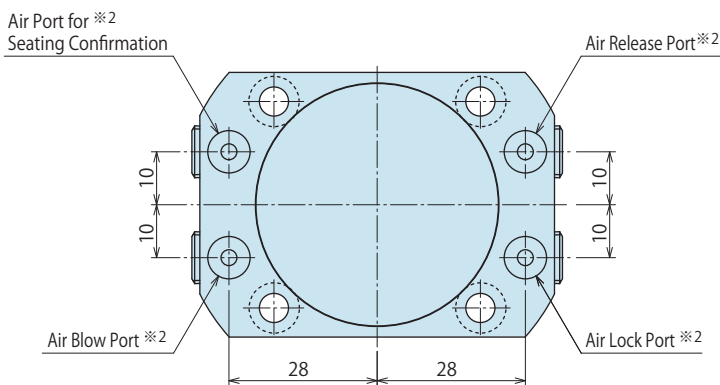
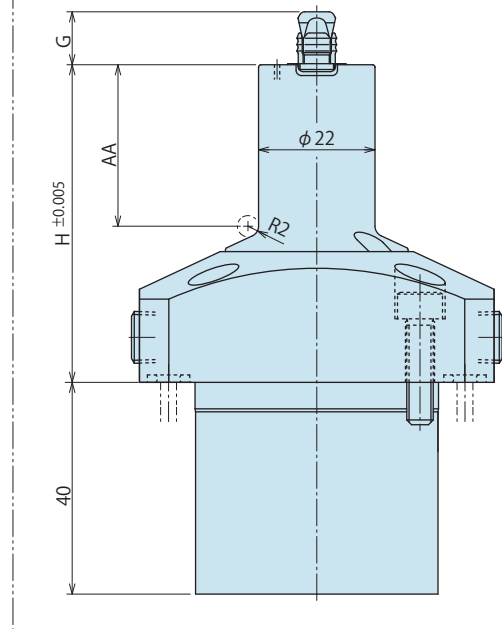

Notes:

- ※1. The workpiece must be resting on all seating surfaces when clamping. If this is not done the workpiece can be deformed by the clamping force.
- ※2. The port names are marked on the product surface. (LOCK: Air Lock Port, RELEASE: Air Release Port, FC: Seating Confirmation Port, BLOW: Air Blow Port) Continuously supply air pressure to the air blow port and the seating confirmation port.
- ※3. The numerical value is only for the workpiece lifting option.
- ※4. Please refer to **Seating Height: Standard** for unlisted dimensions.

Workpiece (Pallet) Hole Dimensions

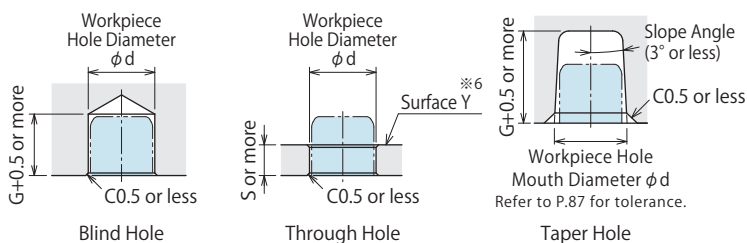

Notes:

- 1. Workpiece hole that is extremely thin can be deformed by clamping action and the specifications will not be fulfilled. Please make sure to test the clamping function before using and adjust to the appropriate supply of pressure.
- ※6. When the clamp head is sticking above the surface Y of the workpiece, please make sure there is no interference with the clamp cylinders during machining.

Machining Dimensions of Mounting Area

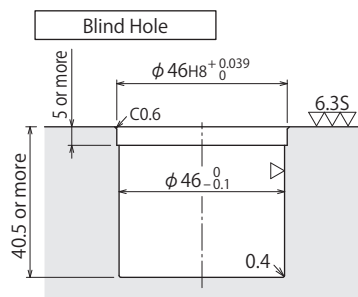
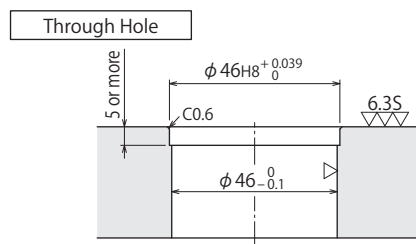
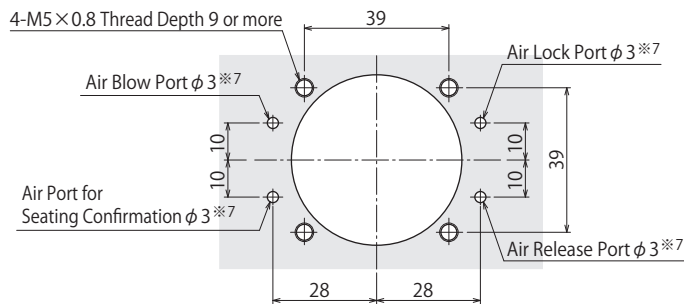

Notes :

1. There should be no burrs at the hole contact surface.

※7. It is not required to machine each port if removing SWE R1/8 thread plug (4 plugs) and setting air fitting and air hose directly.

Model No. Indication

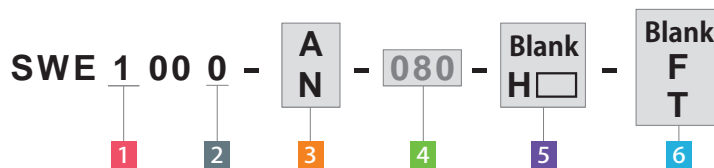

1 Body size (When selecting 1)

2 Design No.

3 Workpiece Lifting Option

4 Workpiece Hole Diameter (Workpiece Hole Code)

5 Seating Height Dimension

6 Workpiece Hole (Gripper) Shape

External Dimensions and Machining Dimensions for Mounting

Model No.	SWE1000-□-□-□-□ (mm)							
4 Workpiece Hole Code	060	065	070	075	080	085	090	
Workpiece Hole Diam. ϕd 7 Blank, F ※10	$6_{-0.3}^{+0.7}$	$6.5_{-0.3}^{+0.7}$	$7_{-0.3}^{+0.7}$	$7.5_{-0.3}^{+0.7}$	$8_{-0.3}^{+0.7}$	$8.5_{-0.3}^{+0.7}$	$9_{-0.3}^{+0.7}$	
Clamp Diameter	Released State	5.5	6	6.5	7	7.5	8	8.5
	Empty Action	7.2	7.7	8.2	8.7	9.2	9.7	10.2
Allowable Offset (Floating Clearance of Expanding Area) ※8	± 0.5							
Full Stroke	4.2							
Workpiece Pulling Stroke	1.0							
Workpiece Lifting Stroke ※9	0.2							
6 Blank, F	G	9	9	9	10	10	10	10
	S	5.5	5.5	5.5	6	6	6	6
	U	5.55	6.05	6.55	7.05	7.55	8.05	8.55
6 T	G	-	9	9	9	10	10	10
	S	-	5.5	5.5	5.5	6	6	6
	U	-	5.45	5.95	6.45	6.9	7.4	7.9
V	8.5	9	9.5	10	10.5	11	11.5	
W	12	13	13	14	14	15	15	

Notes : ※ 8. The clamping part is an adjusting structure and the clamping operation is done by locating the workpiece hole. The numerical value in the table shows the amount of tolerance value of single clamp. Please consider the center distance accuracy of each clamping installation part and each workpiece hole when used with other location clamps / location cylinders, or when using more than two of these products.

※ 9. Workpiece lifting stroke is the function only for lifting option.

※ 10. For -T: Taper Hole model, the allowable tolerance of the hole mouth diameter differs depending on the slope angle. (Refer to P.87.)

5 Seating Height Dimension	Standard Seating Height						
	Blank	H35	H40	H45	H50	H55	H60
H	30	35	40	45	50	55	60
AA	-	5.5	10.5	15.5	20.5	25.5	30.5
Weight kg	0.8	0.8	0.8	0.8	0.8	0.9	0.9

High-Power Series

Pneumatic Series

Hydraulic Series

Valve / Coupler Hydraulic Unit

Manual Operation Accessories

Cautions / Others

High-Power Hydraulic Swing Clamp

LHE

High-Power Hydraulic Link Clamp

LKE

High-Power Pneumatic Hole Clamp

SWE

High-Power Pneumatic Swing Clamp

WHE

High-Power Pneumatic Link Clamp

WCE

High-Power Pneumatic Work Support

WNC

Rodless Hollow Pneumatic Work Support

WNA

High-Power Pneumatic Pallet Clamp

WVS

Machining Dimensions of Mounting Area

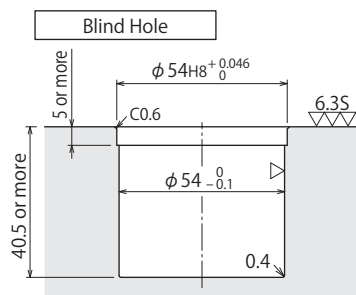
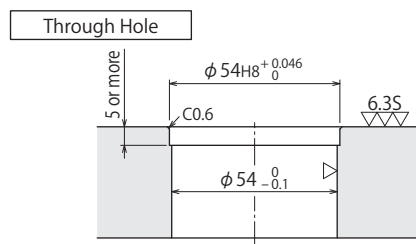
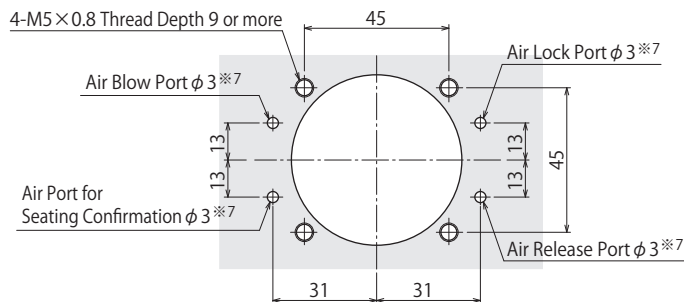

Notes :

1. There should be no burrs at the hole contact surface.

※7. It is not required to machine each port if removing SWE R1/8 thread plug (4 plugs) and setting air fitting and air hose directly.

Model No. Indication

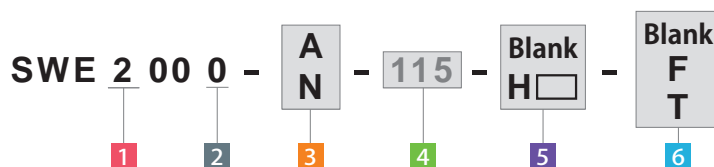

1 Body size (When selecting 2)

2 Design No.

3 Workpiece Lifting Option

4 Workpiece Hole Diameter (Workpiece Hole Code)

5 Seating Height Dimension

6 Workpiece Hole (Gripper) Shape

External Dimensions and Machining Dimensions for Mounting

(mm)

Model No.	SWE2000-□-□-□-□									
4 Workpiece Hole Code	090	095	100	105	110	115	120	125	130	
Workpiece Hole Diam. φ d 7 Blank, F ※10	9 ^{+0.7} _{-0.3}	9.5 ^{+0.7} _{-0.3}	10 ^{+0.7} _{-0.3}	10.5 ^{+0.7} _{-0.3}	11 ^{+0.7} _{-0.3}	11.5 ^{+0.7} _{-0.3}	12 ^{+0.7} _{-0.3}	12.5 ^{+0.7} _{-0.3}	13 ^{+0.7} _{-0.3}	
Clamp Diameter	Released State	8.5	9	9.5	10	10.5	11	11.5	12	12.5
	Empty Action	10.2	10.7	11.2	11.7	12.2	12.7	13.2	13.7	14.2
Allowable Offset (Floating Clearance of Expanding Area) ※8	±0.5									
Full Stroke	4.2									
Workpiece Pulling Stroke	1.0									
Workpiece Lifting Stroke ※9	0.2									
6 Blank, F	G	10	10	10	11.5	11.5	11.5	11.5	11.5	11.5
	S	4.3	4.3	4.3	5.8	5.8	5.8	5.8	5.8	5.8
	U	8.6	9.1	9.6	10.1	10.6	11.1	11.6	12.1	12.6
6 T	G	10	10	10	10	11.5	11.5	11.5	11.5	11.5
	S	4.3	4.3	4.3	4.3	5.8	5.8	5.8	5.8	5.8
	U	8.6	9	9.5	10	10.4	10.9	11.4	11.9	12.4
Mx	8	8	8	8	8	8.6	8.6	9.3	9.3	
R	R2	R2	R2	R3	R3	R3	R3	R3	R3	
V	11.5	12	12.5	13	13.5	14	14.5	15	15.5	
W	15	16	16	17	17	18	18	19	19	
X	24	24	24	24	24	25	25	26	26	
Y	25	25	25	25	25	26	26	27	27	

Notes : ※ 8. The clamping part is an adjusting structure and the clamping operation is done by locating the workpiece hole. The numerical value in the table shows the amount of tolerance value of single clamp. Please consider the center distance accuracy of each clamping installation part and each workpiece hole when used with other location clamps / location cylinders, or when using more than two of these products.

※ 9. Workpiece lifting stroke is the function only for lifting option.

※ 10. For -T: Taper Hole model, the allowable tolerance of the hole mouth diameter differs depending on the slope angle. (Refer to P.87.)

(mm)

5 Seating Height Dimension	Standard Seating Height	Specified Seating Height					
	Blank	H35	H40	H45	H50	H55	H60
H	30	35	40	45	50	55	60
AA	-	5.5	10.5	15.5	20.5	25.5	30.5
Weight kg	1.0	1.0	1.0	1.0	1.1	1.1	1.1

High-Power Series

Pneumatic Series

Hydraulic Series

Valve / Coupler Hydraulic Unit

Manual Operation Accessories

Cautions / Others

High-Power Hydraulic Swing Clamp

LHE

High-Power Hydraulic Link Clamp

LKE

High-Power Pneumatic Hole Clamp

SWE

High-Power Pneumatic Swing Clamp

WHE

High-Power Pneumatic Link Clamp

WCE

High-Power Pneumatic Work Support

WNC

Rodless Hollow Pneumatic Work Support

WNA

High-Power Pneumatic Pallet Clamp

WVS

Layout Sample

※This drawing shows a combination mounting reference of SWE-N (Hole Clamp) and VWM (Expansion Locating Pin).

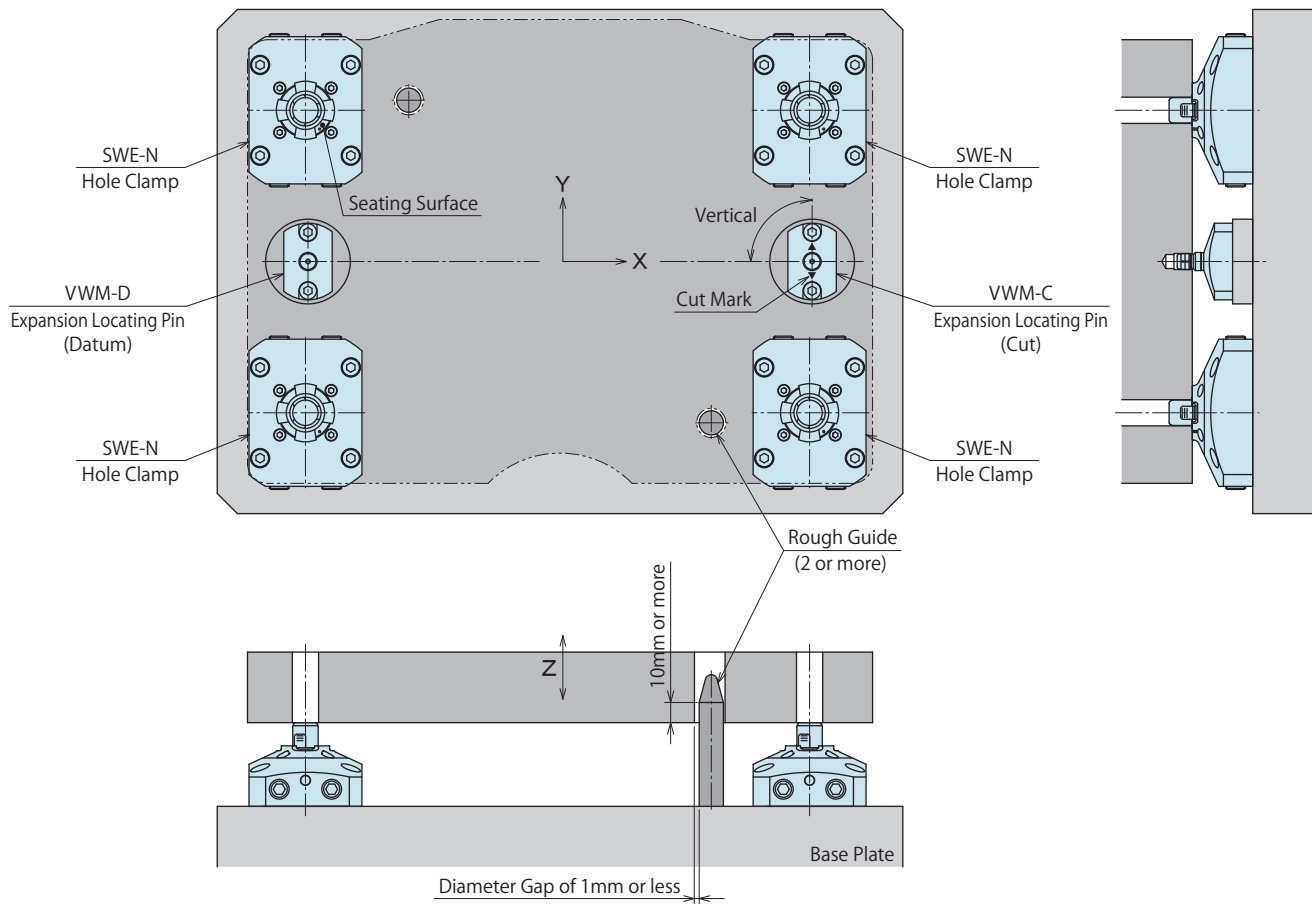

Notes :

1. In order to prevent the clamping part from damage, please set up rough guide of 2 or more when detaching a workpiece.
Please refer to the above drawing for the length of rough guide and the diameter gap.
(Use of rough guides depends on the loading / unloading condition of the workpiece.)
2. When using a combination of VWM (Expansion Locating Pin) and SWE-N (Hole Clamp), please choose N:Without lifting function.

● Pneumatic Circuit Reference

※ This drawing shows a combination circuit reference of SWE-N (Hole Clamp) and VWM (Expansion Locating Pin).

When controlled with one solenoid valve

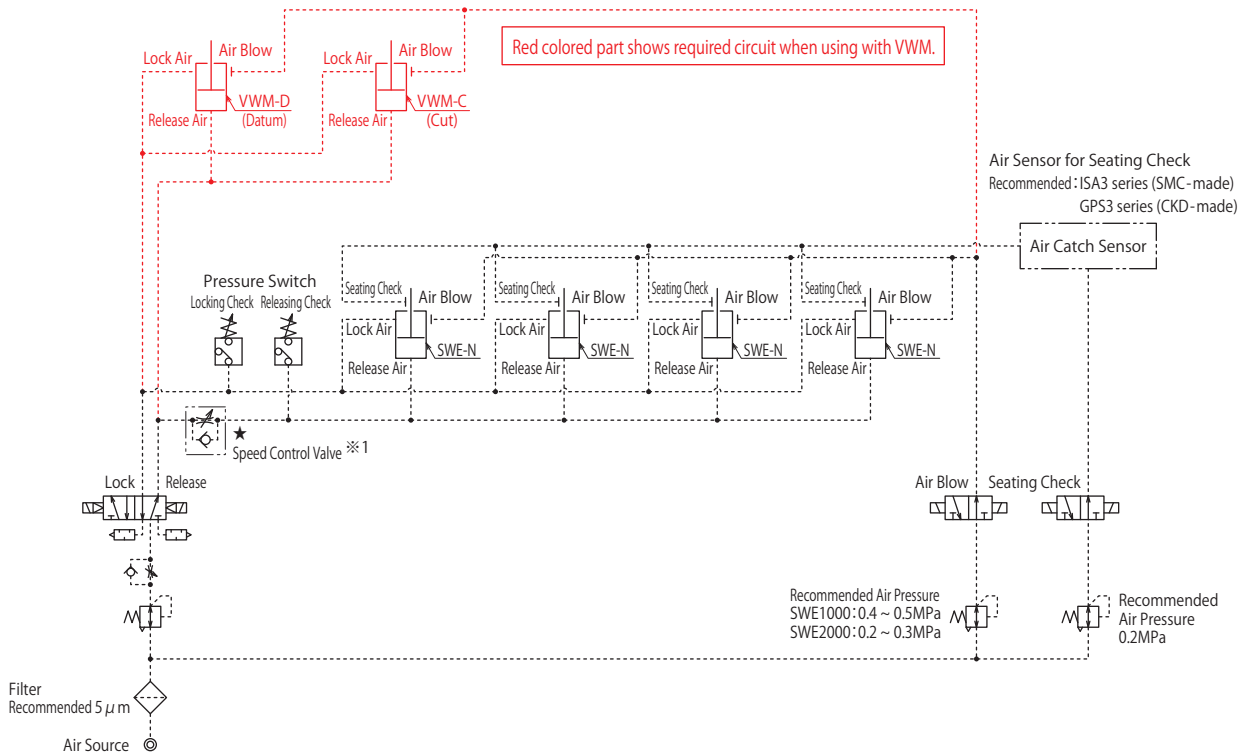

When controlled with two solenoid valves

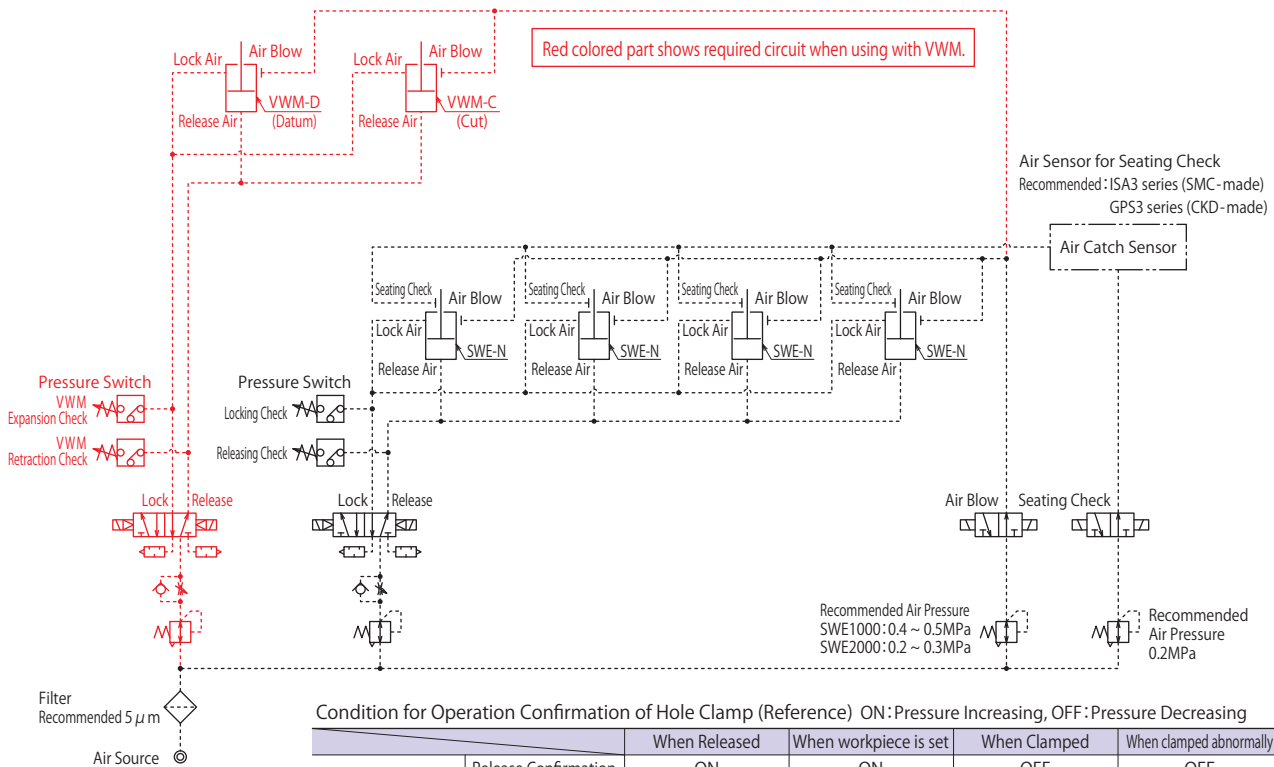

Condition for Operation Confirmation of Hole Clamp (Reference) ON: Pressure Increasing, OFF: Pressure Decreasing

		When Released	When workpiece is set	When Clamped	When clamped abnormally
Pressure Switch	Release Confirmation	ON	ON	OFF	OFF
	Lock Confirmation	OFF	OFF	ON	ON (OFF when air leaks)
Air Sensor for Seating Confirmation		OFF	ON(OFF)※3	ON	OFF

Notes :

- ※1. Please use solenoid valve to make a sequence operation that SWE (Hole Clamp) starts working after VWM (Expansion Locating Pin) completes the movement. When unable to use solenoid valve, please prepare flow control valve with check valve at ★ (1 piece) to adjust sequencing speed. If SWE operates before VWM, there is a possibility for the product to be damaged due to a thrust load on SWE.
- ※2. In case high accuracy is required for air sensor setting, please install an air sensor for individual clamp.
- ※3. With lifting function it shows "OFF" since there is a gap between seating surface and workpiece. Without lifting function, it shows "ON" depending on set pressure of the air sensor.

High-Power Series

Pneumatic Series

Hydraulic Series

Valve / Coupler Hydraulic Unit

Manual Operation Accessories

Cautions / Others

High-Power Hydraulic Swing Clamp

LHE

High-Power Hydraulic Link Clamp

LKE

High-Power Pneumatic Hole Clamp

SWE

High-Power Pneumatic Swing Clamp

WHE

High-Power Pneumatic Link Clamp

WCE

High-Power Pneumatic Work Support

WNC

Rodless Hollow Pneumatic Work Support

WNA

High-Power Pneumatic Pallet Clamp

WVS

Cautions

Notes for Design

1) Check Specifications

- Please use each product according to the specifications.
- This product is an air double-acting model which locks with air pressure and spring force, and releases with air pressure. Even when air is not supplied to either lock port or release port, built-in spring maintains locked condition (clamp diameter is expanded):
 - ① Maintains clamping force even when air pressure is at 0MPa. (Refer to the clamping force curve : clamping force at supply air pressure 0MPa on P.90).
 - ② Supply release air when loading/unloading a workpiece. If release air is not supplied, the workpiece contacts with the gripper leading to breakage of the workpiece and the clamp.

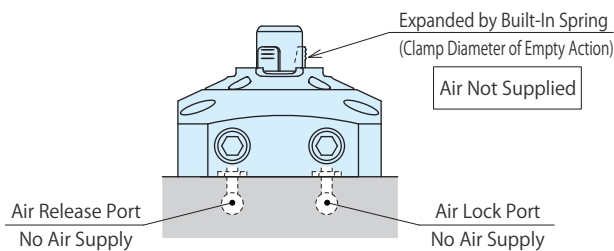

2) Working Reference Plate (Seating Surface) Z axis.

- The upper surface of the flange of this product is the seating surface of workpiece and locates in Z direction.

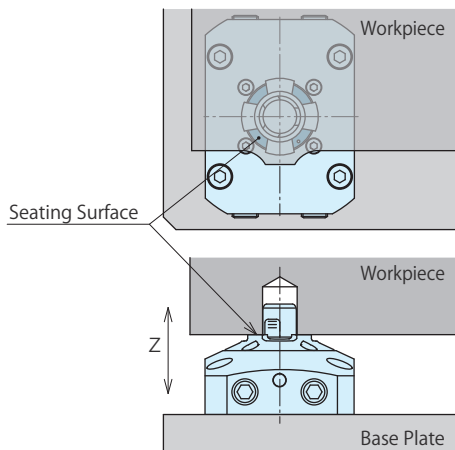

When clamping, make sure all seating surfaces touch a workpiece. When the workpiece is not touching the seating surface area, please refer to external dimension chart and calculate contacting pressure with clamping force and seating area not to deform the workpiece.

3) Seating Confirmation Mechanism

- It will be detected when a workpiece is pressed against the seating surface by locking (clamping) action.

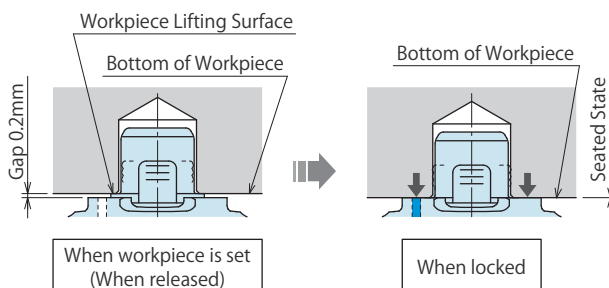

With lifting function, when a workpiece is set (before supplying lock air pressure), the workpiece is lifted by built-in spring, and there will be a gap of 0.2mm between workpiece bottom surface and seating surface.

4) Clamp Installation

- The clamping part of this product has floating structure ($\pm 0.5\text{mm}$). Please consider the center distance accuracy of each clamping installation part and each workpiece hole when used with other location clamps / location cylinders, or when using more than two of these products.

5) Clamping Force

- Clamping force shows a pressing force against the seating surface. Make sure to conduct test clamping and adjust supply pressure accordingly. Insufficient clamping force leads to workpiece detachment.

6) Workpiece hole size, slope angle and workpiece hardness should be within the range of the specification.

When workpiece hole diameter is larger than specification.	Expansion stroke is insufficient and the clamping force will not fill the specifications.
When using it with insufficient clamping force.	Leads to falling of the workpiece.
When workpiece hole diameter is smaller than specification.	Difficult to attach/detach the workpiece leading to damage.
When workpiece hole depth is shallow.	May lead to abnormal seating and damage.
When workpiece hole taper slope angle is larger than specification.	The load concentrates on the gripper point when clamping and could lead to damage.
When workpiece hole is harder than specified.	Gripper does not dig into the workpiece enough and it cannot clamp securely.

7) Wall Thickness around Workpiece Hole

- Thin wall around the workpiece hole could be deformed by clamping action, and clamping force does not fill the specification. Make sure to conduct test clamping and adjust supply pressure accordingly. Insufficient clamping force leads to workpiece detachment.

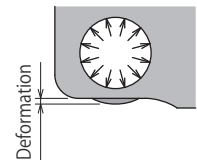

8) Air Blow Port and Seating Confirmation Port

- Continuously supply air pressure to the air blow port and the seating confirmation port. If air supply is shut off during operation, contaminants enter into the clamp leading to malfunctions.

High-Power Series
Pneumatic Series
Hydraulic Series
Valve / Coupler Hydraulic Unit
Manual Operation Accessories
Cautions / Others

High-Power Hydraulic Swing Clamp

LHE

High-Power Hydraulic Link Clamp

LKE

High-Power Pneumatic Hole Clamp
SWE

High-Power Pneumatic Swing Clamp

WHE

High-Power Pneumatic Link Clamp

WCE

High-Power Pneumatic Work Support

WNC

Rodless Hollow Pneumatic Work Support

WNA

High-Power Pneumatic Pallet Clamp

WVS

9) Release Action

- When releasing, it lifts up a workpiece which is normal. When using in a horizontal application, it is recommended to install a fall prevention of workpiece for temporal tacking.

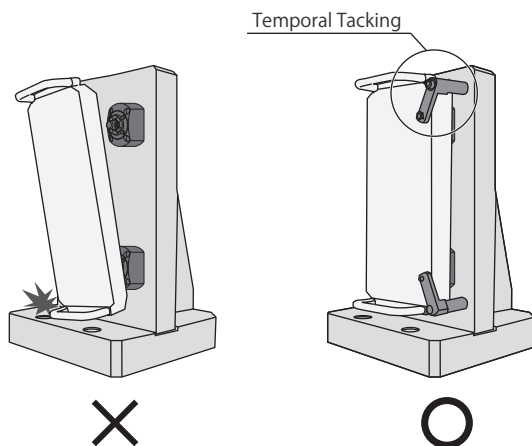
10) Horizontal Locating

- When a workpiece is set, please make sure there is no lifting or slope of the workpiece. If the clamping operation is done with lifting or slope of the workpiece, it will lead to possible damage of a clamp and deformation of the workpiece hole.

11) Please detach a workpiece with all clamps fully released.

- When a workpiece is detached during lock or release operation, it will lead to damage of clamp or fall of workpiece.

12) Please set up rough guides.

- When detaching a workpiece with slope it may cause damage of clamp or fall of workpiece.

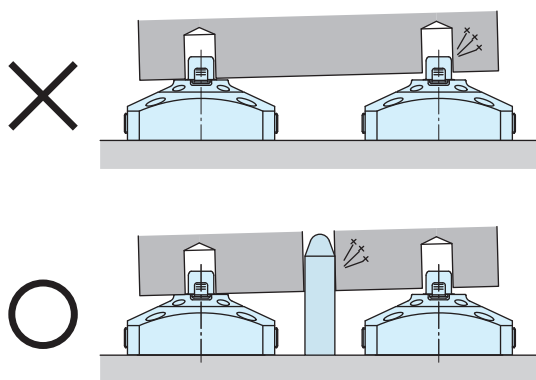

When using the product with other location clamps / cylinders, please set rough guides considering the center distance accuracy of each mounting hole and workpiece hole of location clamp / cylinder.

13) Damage Prevention during Robot Handling, etc.

- When inserting the SWE tip into/taking it out of a workpiece hole, the SWE tip has to be vertical to the workpiece hole. Especially after releasing a workpiece, the SWE tip must be fully taken out from the workpiece hole before moving to a next coordinate.

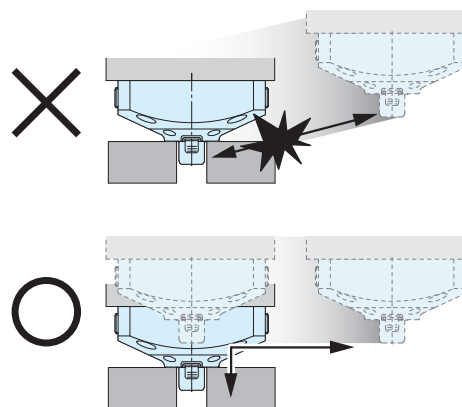

- If the SWE tip touches a workpiece when inserting, control the insertion speed to avoid damage on the workpiece and the SWE tip.

- When SWE is clamping/releasing a workpiece, make sure that the robot operates only after SWE completes clamping/releasing action by using a sensor or a timer. If the robot starts operating in the middle of clamping/releasing action, the workpiece may be fallen off.

- When clamping/releasing a workpiece, it may be tilted due to a gap between the workpiece and the stand. This causes damage of SWE. The gap has to be minimized as much as possible when clamping/releasing.

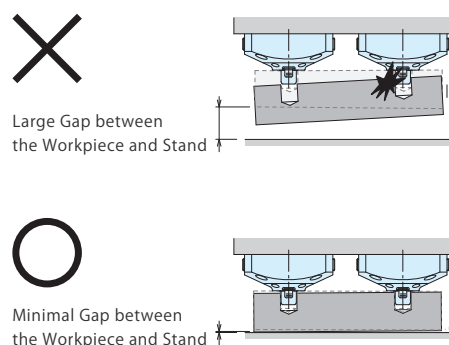

Cautions

Installation Notes

- 1) Check the Usable Fluid
 - Make sure to supply filtered clean dry air.
 - Oil supply with a lubricator etc. is unnecessary.
- 2) Procedure before Piping
 - The pipeline, piping connector and fixture circuits should be cleaned by thorough flushing.
Dust and cutting chips in the circuit may lead to air leakage and malfunction.
 - There is no filter provided with this product to prevent contaminants from getting into the air circuit.
- 3) Applying Sealing Tape
 - Wrap with tape 1 to 2 times following the screw direction.
 - Pieces of the sealing tape can lead to air leakage and malfunction.
 - In order to prevent contamination during the piping work, it should be carefully cleaned before working.
- 4) Installation of the Product
 - When mounting the product, use all hexagon socket bolts (with tensile strength of 12.9) and tighten them with the torque shown in the following table.

Model No.	Mounting Bolt Size	Tightening Torque (N·m)
SWE	M5×0.8	6.3

- 5) Port Position of the Hole Clamp
 - The port names are marked on the product surface.
Be careful of installation direction.
(LOCK : Air Lock Port, RELEASE : Air Release Port,
FC : Seating Confirmation Port, BLOW : Air Blow Port)
- 6) Use air piping with outer diameter $\phi 6$ (inner diameter $\phi 4$) or larger for air blow.
 - In order to conduct an effective air blow, it is recommended to use air piping with outer diameter $\phi 6$ (inner diameter $\phi 4$) or larger.

Notes on Handling

- 1) It should be handled by qualified personnel.
 - Machines and devices with hydraulic and pneumatic equipment should be handled and maintained by qualified personnel.
- 2) Do not handle or remove the product unless the safety protocols are ensured.
 - ① The machine and equipment can only be inspected or prepared when it is confirmed that the preventive devices are in place.
 - ② Before the product is removed, make sure that the above-mentioned safety measures are in place. Shut off the pressure and power source, and make sure no pressure exists in the air and hydraulic circuits.
 - ③ After stopping the product, do not remove until the temperature drops.
 - ④ Make sure there is no abnormality in the bolts and respective parts before restarting the machine or equipment.
- 3) Do not touch workpieces (pallets) or clamps while they are working. Otherwise, your hands may be injured due to clinching.



- 4) Do not disassemble or modify.
 - If the equipment is taken apart or modified, the warranty will be voided even within the warranty period.
 - Built-in spring is very strong and can be dangerous.

**High-Power
Series**

Pneumatic Series

Hydraulic Series

Valve / Coupler
Hydraulic UnitManual Operation
Accessories

Cautions / Others

High-Power Hydraulic
Swing Clamp

LHE

High-Power Hydraulic
Link Clamp

LKE

**High-Power Pneumatic
Hole Clamp**
SWE
High-Power Pneumatic
Swing Clamp

WHE

High-Power Pneumatic
Link Clamp

WCE

High-Power Pneumatic
Work Support

WNC

Rodless Hollow
Pneumatic Work Support

WNA

High-Power Pneumatic
Pallet Clamp

WVS

● Maintenance and Inspection

- 1) Please refer to P.1357 for general maintenance and inspection.
- 2) Regularly clean the clamping part and the seating surface.
 - There is an air blow mechanism in this product, and cutting chips and coolant can be removed. However, as it may be hard to remove clinging cutting chips, sludge, etc., please confirm there are no contaminants when a workpiece is set. If operating with dirt adhering to the clamping part, it will lead to a workpiece fall due to insufficient clamping force, defective operation, and air leakage etc.

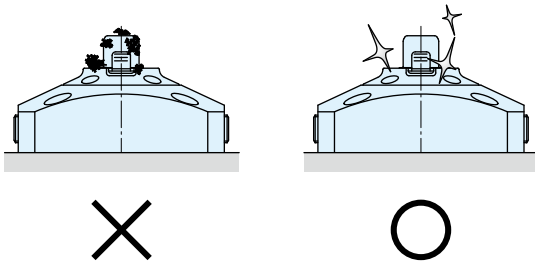

Even with general cleaning on exterior of hole clamp, there may be contaminants within internal parts of the component. If necessary, please call us for repair. If repair or modifications are carried out by anyone other than Kosmek, or without our approval or confirmation, it will void warranty.

- 3) Clamping force will be decreased by friction of a gripper surface due to repeated operation. Replacement period differs depending on operating pressure, workpiece material and shape of hole. When you find friction on gripper surface, the gripper needs to be replaced. Please contact us for overhaul.

Material of Clamping Hole	Gripper Replacement Frequency Guide
A2017 Aluminum	Locking operation 1 million cycles
SCM435 Thermal Refined Steel	Locking operation 500,000 cycles

※ It varies depending on the operating conditions. Please request an overhaul after confirming its suitability for the actual machine.

- 4) Please contact us for overhaul and repairs.
Built-in spring is very strong and can be dangerous.

※ Please refer to P.1357 for common cautions.

• Notes on Handling

• Maintenance/Inspection

• Warranty

ⓘ Cautions

● Notes on Handling

- 1) It should be operated by qualified personnel.
 - The hydraulic machine and air compressor should be operated and maintained by qualified personnel.
- 2) Do not operate or remove the product unless the safety protocols are ensured.
 - ① The machine and equipment can only be inspected or prepared when it is confirmed that the safety devices are in place.
 - ② Before the product is removed, make sure that the above-mentioned safety devices are in place. Shut off the pressure and power source, and make sure no pressure exists in the air and hydraulic circuits.
 - ③ After stopping the product, do not remove until the temperature drops.
 - ④ Make sure there is no abnormality in the bolts and respective parts before restarting the machine or equipment.
- 3) Do not touch a clamp (cylinder) while it is working. Otherwise, your hands may be injured due to clinching.

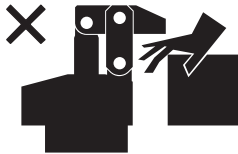

- 4) Do not disassemble or modify.
 - If the equipment is taken apart or modified, the warranty will be voided even within the warranty period.

● Maintenance and Inspection

- 1) Removal of the Machine and Shut-off of Pressure Source
 - Before the machine is removed, make sure that safety devices and preventive devices are in place. Shut off the pressure and power source, and make sure no pressure exists in the air and hydraulic circuits.
 - Make sure there is no abnormality in the bolts and respective parts before restarting.
- 2) Regularly clean the area around the piston rod and plunger.
 - If it is used when the surface is contaminated with dirt, it may lead to packing seal damage, malfunctioning and fluid leakage.

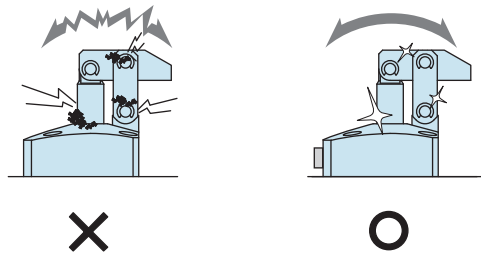

- 3) Please clean out the reference surfaces on a regular basis (taper reference surface and seating surface) of the locating products. (VS/VT/VFL/VFM/VFJ/VFK/WVS/VWM/VWK/VX/VXE/VXF)
 - The locating products, except VX/VXE/VXF model, can remove contaminants with cleaning functions. However, hardened cutting chips, adhesive coolant and others may not be removed. Make sure there are no contaminants before installing a workpiece/pallet.
 - Continuous use with contaminant on components will lead to locating accuracy failure, malfunction and fluid leakage.

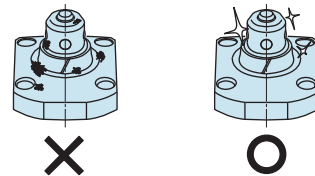

- 4) If disconnecting by couplers, air bleeding should be carried out on a regular basis to avoid air mixed in the circuit.
- 5) Regularly tighten nut, bolt, pin, cylinder, pipe line and others to ensure proper use.
- 6) Make sure the hydraulic fluid has not deteriorated.
- 7) Make sure there is a smooth action without an irregular noise.
 - Especially when it is restarted after left unused for a long period, make sure it can be operated correctly.
- 8) The products should be stored in the cool and dark place without direct sunshine or moisture.
- 9) Please contact us for overhaul and repair.

● Warranty

1) Warranty Period

- The product warranty period is 18 months from shipment from our factory or 12 months from initial use, whichever is earlier.

2) Warranty Scope

- If the product is damaged or malfunctions during the warranty period due to faulty design, materials or workmanship, we will replace or repair the defective part at our expense.

Defects or failures caused by the following are not covered.

- ① If the stipulated maintenance and inspection are not carried out.
- ② If the product is used while it is not suitable for use based on the operator's judgment, resulting in defect.
- ③ If it is used or operated in an inappropriate way by the operator. (Including damage caused by the misconduct of the third party.)
- ④ If the defect is caused by reasons other than our responsibility.
- ⑤ If repair or modifications are carried out by anyone other than Kosmek, or without our approval and confirmation, it will void warranty.
- ⑥ Other caused by natural disasters or calamities not attributable to our company.
- ⑦ Parts or replacement expenses due to parts consumption and deterioration. (Such as rubber, plastic, seal material and some electric components.)

Damages excluding from direct result of a product defect shall be excluded from the warranty.

High-Power
Series

Pneumatic Series

Hydraulic Series

Valve / Coupler
Hydraulic Unit

Manual Operation
Accessories

Cautions / Others

Cautions

Installation Notes
(For Hydraulic Series)

Hydraulic Fluid List

Notes on Hydraulic Cylinder
Speed Control Circuit

Notes on Handling

Maintenance/
Inspection

Warranty

Company Profile

Company Profile

Our Products

History

Index

Search by
Alphabetical Order

Sales Offices

Sales Offices

Sales Offices across the World

Japan	KOSMEK LTD. HEAD OFFICE	TEL. +81-78-991-5162 FAX. +81-78-991-8787 1-5, 2-chome, Murotani, Nishi-ku, Kobe-city, Hyogo, Japan 651-2241
USA	KOSMEK (USA) LTD. Overseas Subsidiary	TEL. +1-630-620-7650 FAX. +1-630-620-9015 650 Springer Drive, Lombard, IL 60148 USA
	KOSMEK USA ATLANTA BRANCH OFFICE	TEL. +1-630-620-7650 303 Perimeter Center North, Suite 300, Atlanta, GA 30346 USA
Mexico	KOSMEK USA MEXICO BRANCH OFFICE	TEL. +52-442-851-1377 Av. Loma Pinal de Amoles 320-piso PH oficina 504 interior 13, Vista Dorada, 76060 Santiago de Querétaro, Qro. Mexico
Europe	KOSMEK EUROPE GmbH Overseas Subsidiary	TEL. +43-463-287587 FAX. +43-463-287587-20 Schleppeplatz 2 9020 Klagenfurt am Wörthersee Austria
China	KOSMEK (CHINA) LTD. Overseas Subsidiary	TEL.+86-21-54253000 FAX. +86-21-54253709 Room601, RIVERSIDE PYRAMID No.55, Lane21, Pusan Rd, Pudong Shanghai China
	KOSMEK (CHINA) LTD. Dongguan Office Overseas Subsidiary (Sales Office)	TEL.+86-769-85300880 Room 603, Xinchuang Power Building (No. 122-1 West Houjie Avenue), Houjie Town, Dongguan City, Guangdong Province, China
	KOSMEK (CHINA) LTD. Wuhan Office Overseas Subsidiary (Sales Office)	TEL.+86-15802172393 Room 309, Chuanggu Technology Building, 266 Taizihu Rd, Zhuankou Subdistrict, Caidian District, Wuhan 430056, Hubei Province, China
India	KOSMEK LTD. - INDIA Branch	TEL. +91-9880561695 4A/Old No:649, Ground Floor, 4th D cross, MM Layout, Kavalbyrasandra, RT Nagar, Bangalore -560032 India
Thailand	KOSMEK Thailand Representative Office Representative Office	TEL. +66(0)2-059-2010 No.139, Blue Chips Building, 4th Floor, Room No.422, Soi Sukhumvit 63 (Thong Lor 10), Sukhumvit Road, Khlong Tan Nuea, Wattana, Bangkok 10110, Thailand
Taiwan	FULL LIFE TRADING CO., LTD. Distributor	TEL. +886-2-82261860 FAX. +886-2-82261890 16F-4, No.2, Jian Ba Rd., Zhonghe District, New Taipei City Taiwan 23511
Philippines	G.E.T. Inc, Phil. Distributor	TEL.+63-2-310-7286 FAX. +63-2-310-7286 Victoria Wave Special Economic Zone Mt. Apo Building, Brgy. 186, North Caloocan City, Metro Manila, Philippines 1427
Indonesia	PT. Yamata Machinery Sales Distributor	TEL. +62-21-29628607 FAX. +62-21-29628608 Delta Commercial Park I, Jl. Kenari Raya B-08, Desa Jayamukti Kec. Cikarang Pusat Kab. Bekasi 17530 Indonesia

Sales Offices in Japan

Head Office Osaka Sales Office Overseas Sales	TEL. 078-991-5162 FAX. 078-991-8787 1-5, 2-chome, Murotani, Nishi-ku, Kobe-city, Hyogo, 651-2241, Japan
Tokyo Sales Office	TEL. 048-652-8839 FAX. 048-652-8828 81, 4-chome, Onari-cho, Kita-ku, Saitama City, Saitama, 331-0815, Japan
Nagoya Sales Office	TEL. 0566-74-8778 FAX. 0566-74-8808 10-1, 2-chome, Misono-cho, Anjo City, Aichi, 446-0076, Japan
Fukuoka Sales Office	TEL. 092-433-0424 FAX. 092-433-0426 8-10-101, 1-chome, Kamimuta, Hakata-ku, Fukuoka City, Fukuoka, 812-0006, Japan

Global Network

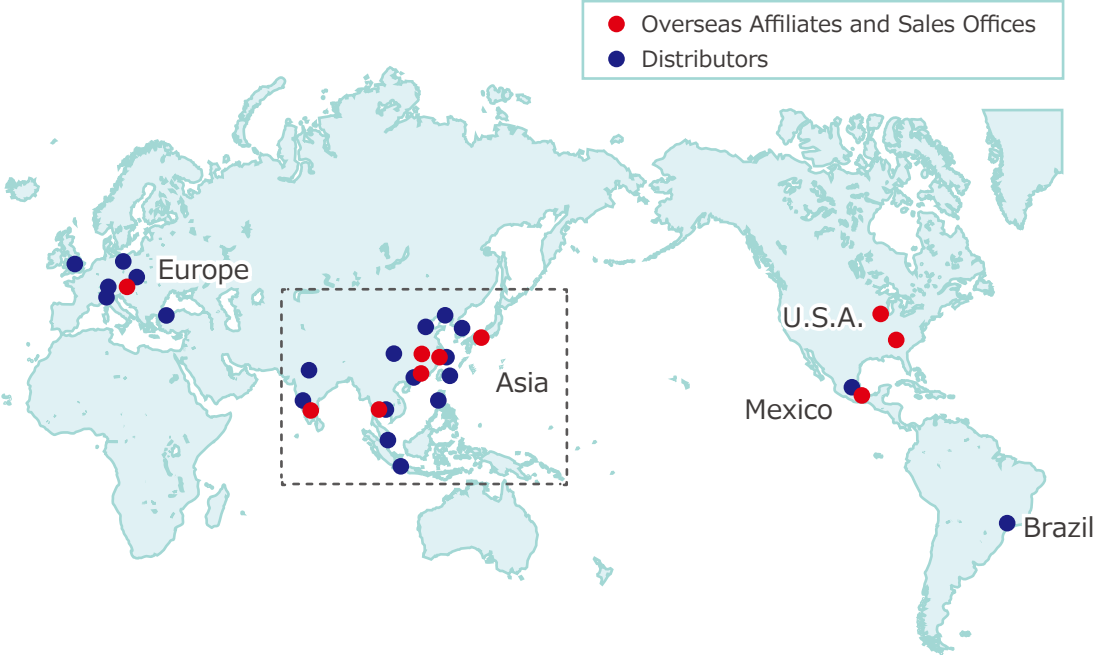

Asia Detailed Map



● FOR FURTHER INFORMATION ON UNLISTED SPECIFICATIONS AND SIZES, PLEASE CALL US.
● SPECIFICATIONS IN THIS CATALOG ARE SUBJECT TO CHANGE WITHOUT NOTICE.

