

# Pneumatic Hole Clamp

Model SWA



Gripper expands and pulls workpiece in.

PAT.

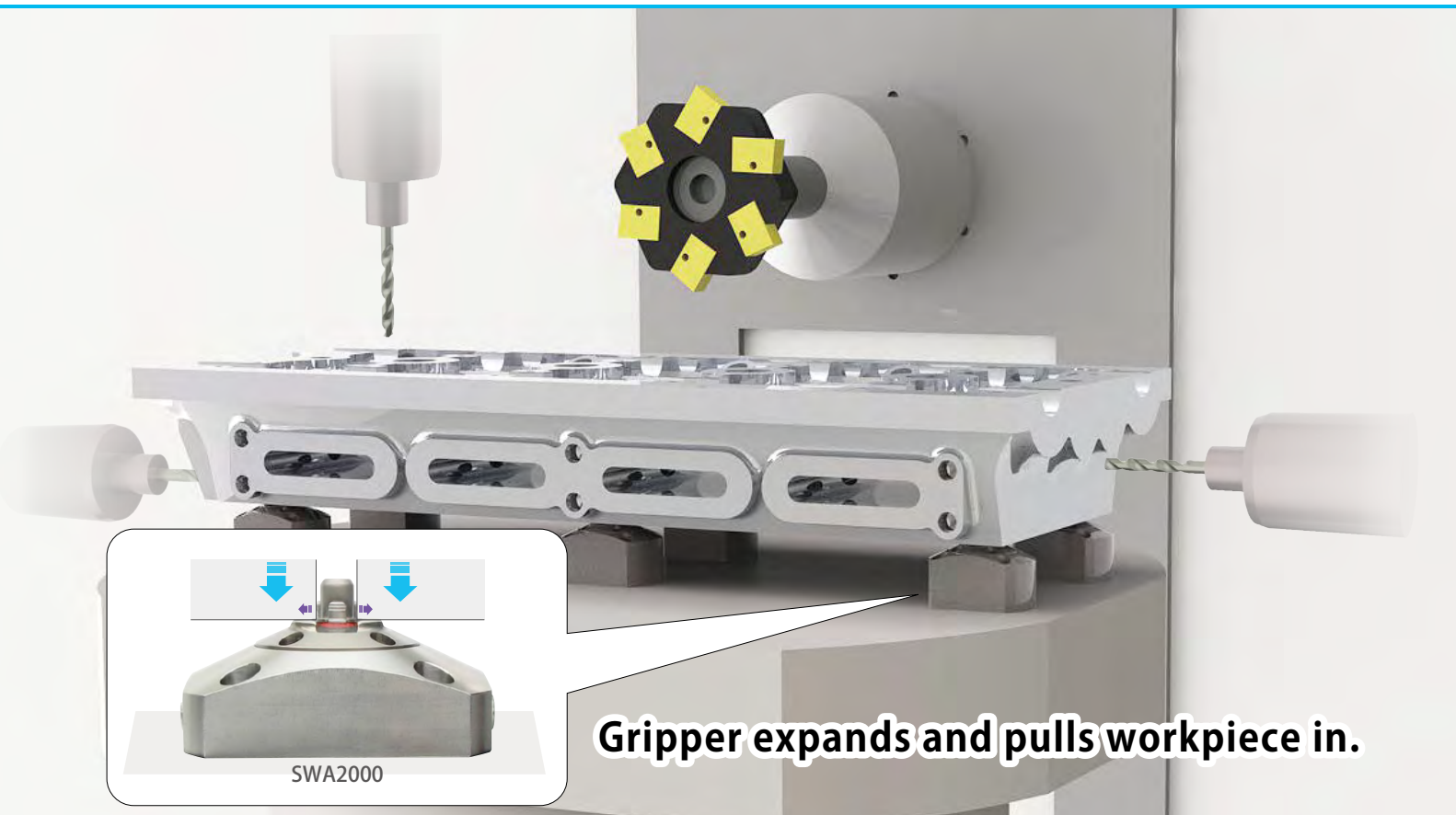

## Action Description (The Tip of Hole Clamp)

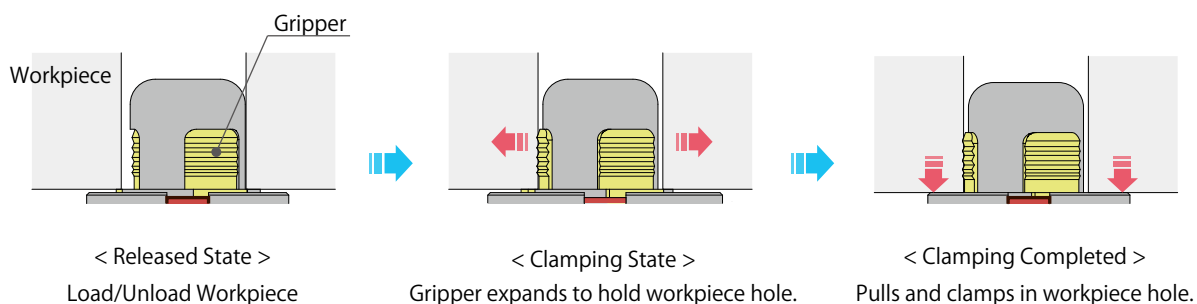

## Advantages

 High-Power  
Series

Pneumatic Series

Hydraulic Series

 Valve / Coupler  
Hydraulic Unit

 Manual Operation  
Accessories

Cautions / Others

 Pneumatic  
Hole Clamp

SWA

 Pneumatic  
Swing Clamp

WHA

 Double Piston  
Pneumatic Swing Clamp

WHD

 Pneumatic  
Link Clamp

WCA

 Air Flow  
Control Valve

BZW

 Pneumatic  
Expansion Locating Pin

VWM

VWK

 Pneumatic  
Sensor Pin

WWA

### ● To Workpiece

- Zero interference with 5 faces except clamping face.
- Possible to use standard length tool which provides for better machining accuracy.
- Possible to enhance cutting parameters which leads to shorter cycle times.

### ● To Machining Equipment

- Fixture could be extremely downsized.
- Turn-table could be downsized.
- The movement of tool could be shorten.
- For saving weight of fixture.
- Machining equipment could be more simple.
- Good design for easy flow of chips and reduction in coolant usage.

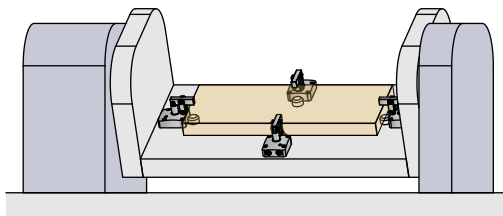

<Before> Clamping around the Workpiece

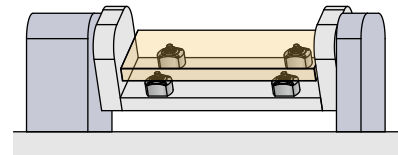

<After> Using the Hole Clamps

### ● To Machining Line

- 5-face machining makes it possible to put process together.
- Machining line is kept small and simple.
- Possible to enhance cutting parameters which leads to shorter cycle times.

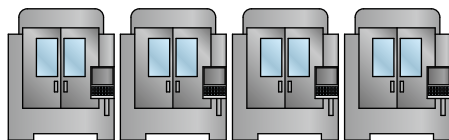

<Before> Large Machining Centers  
and Long Machining Lines.

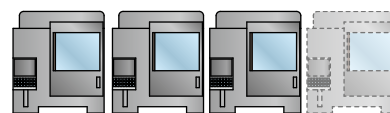

<After> Smaller Machining Centers  
and Shorter Machining Lines.

### ● To Transfer Equipment

- Hand part can be compact and light.
- Transfer equipment can be compact.

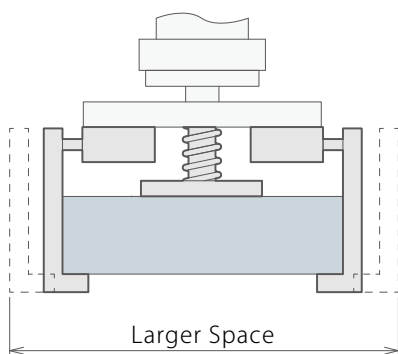

<Before> Transfer Hand with Linear Cylinder

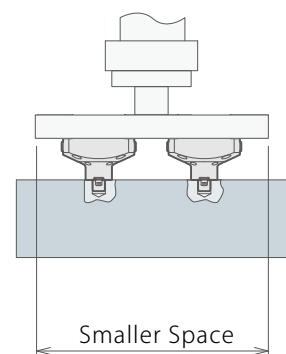

<After> Transfer Hand with Hole Clamp

Features

• Variable Mounting Dimensions to Suit the Equipment

All pipes are set in flange so plate thickness would be much thinner.

The body below flange is shorter and lighter than high-power pneumatic hole clamp (model SWE).

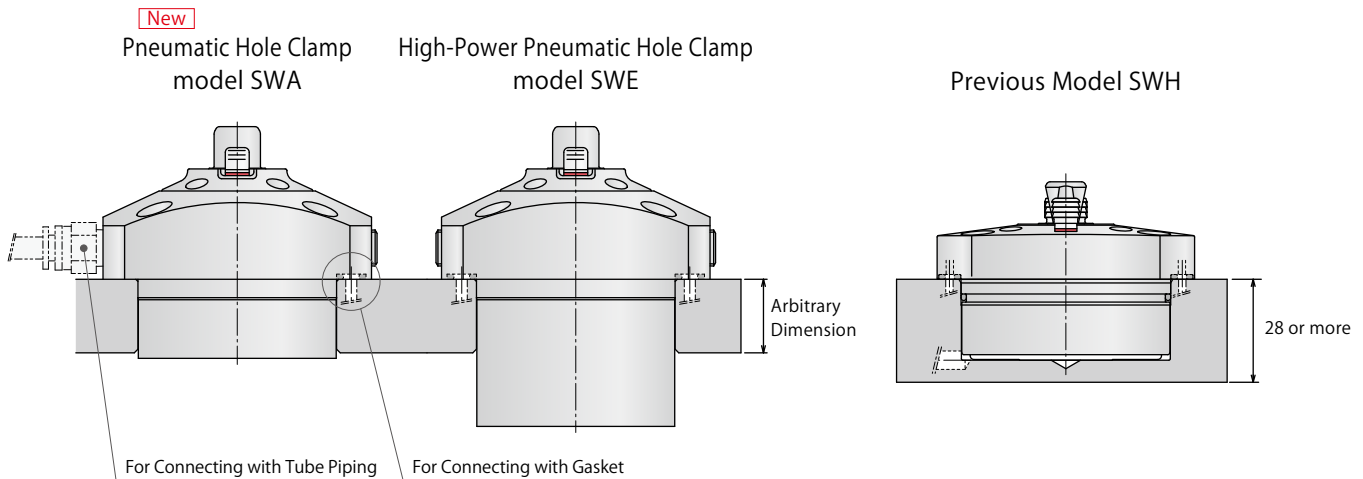

• Seating Surface Height Suitable to Workpiece

Level the height in 5mm increments according to the phase of workpiece seating surface.

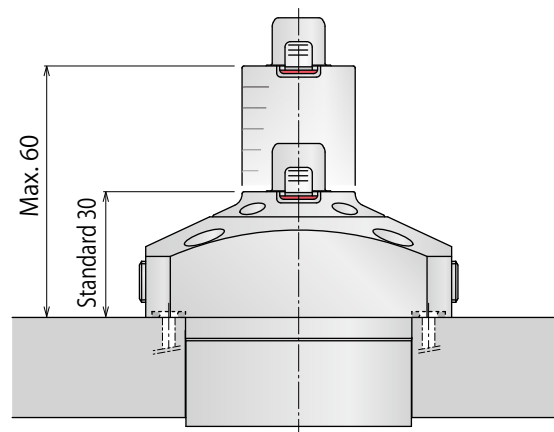

• Hole Diameter to Suit a Variety of Workpieces

In order to suit different hole diameters and tolerances, hole diameters can be specified in 0.5mm increments.

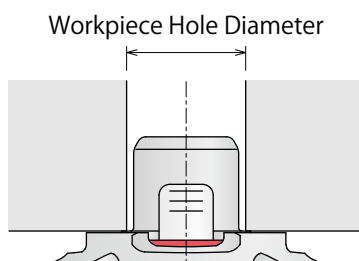

Model No.	Workpiece Hole Diameter (mm)													
	6	6.5	7	7.5	8	8.5	9	9.5	10	10.5	11	11.5	12	12.5
SWA1000	Body Size – Type 1													
SWA2000								Body Size – Type 2						

※ Refer to the specifications for the tolerance of workpiece hole diameter.

## ● Without Pulling Function (Option)

It has expanding force only, and minimizes deformation caused by clamping.

※ Workpiece pulling stroke per clamp is max. 0.1mm.

### 【Standard】

Built-in locking spring and lift spring enable secure clamping and self-locking at zero air pressure.

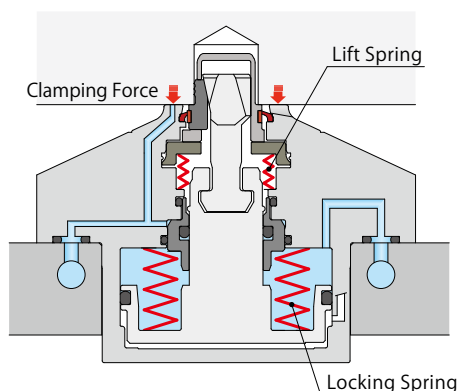

### 【Option : Without Pulling Function】

Not equipped with lift spring, and workpiece pulling stroke is minimum. It clamps a workpiece with expanding force only.

※ This option has no seating confirmation function, but clamp abnormality detection function.

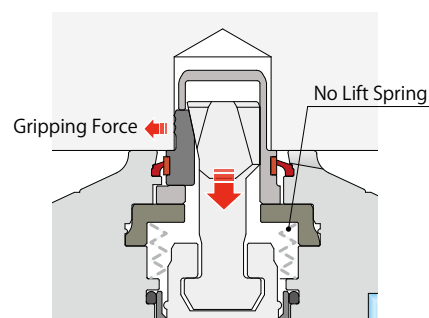

<Deformation Analysis> Color Indication : Less Deformation (Blue)  (Red) Lager Deformation

Since clamping force is applied toward the pulling direction, the workpiece hole might be deformed.

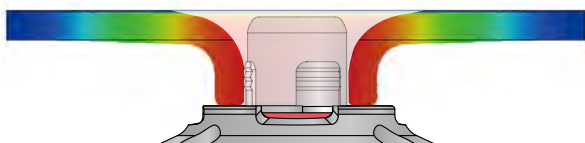

By clamping with expanding force only, there is no force applied or deformation occurred toward the pulling direction.

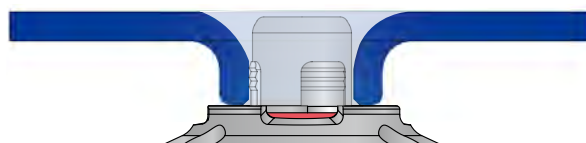

<Application Example of 'Without Pulling Function' Option : Supports the Displacement of Lifting Direction with Hole Clamp>

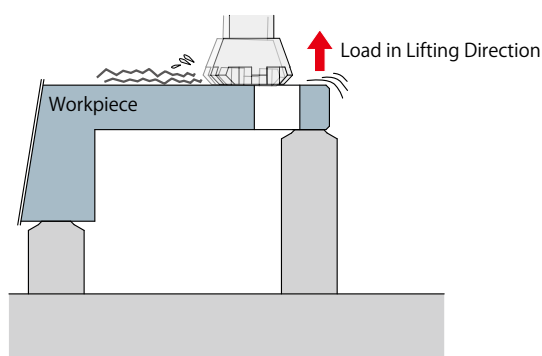

#### 【Without Hole Clamp】

Due to the load in lifting direction, there is deflection when machining the workpiece.

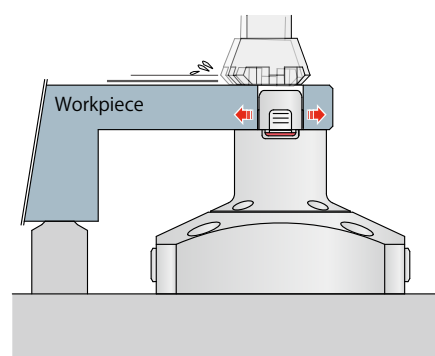

#### 【Support with Hole Clamp】

Grips the workpiece, prevents deflection in lifting direction and improves machining accuracy.

Note : In case there is thrust load (vertical load toward the hole clamp axis), 'without pulling function' has no clamping force, so the product will be damaged or broken when thrust load is applied to the hole clamp.

Make sure to use a support, etc. for thrust load.

## Features

### • Various Kinds of Protection by Cap Structure

All sizes are equipped with the cap.



- Minimum clearance between cap and gripper prevents cutting chips from entering inside.

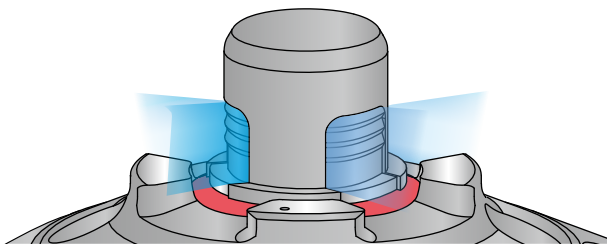

- Small clearance leads to effective purging. Even with a little air flow it prevents coolant from entering inside.

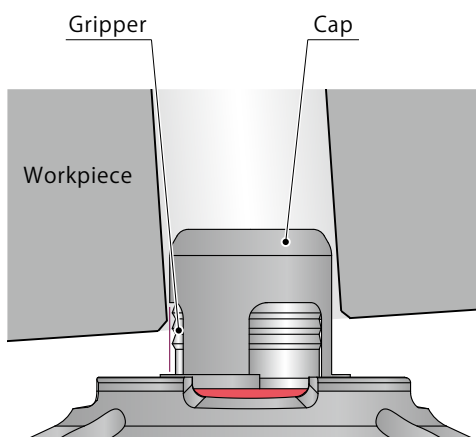

- Workpiece does not have contact with gripper. It makes loading-unloading smooth.
- Not necessary to have rough guide on fixture.

※ Depends on the condition of loading speed, etc.

## ● Pursuit of Good Design for Efficient Swarf Management

Having smaller seating surface and wide sweep area on the flange enables easy flow of chips and reduction in coolant usage.

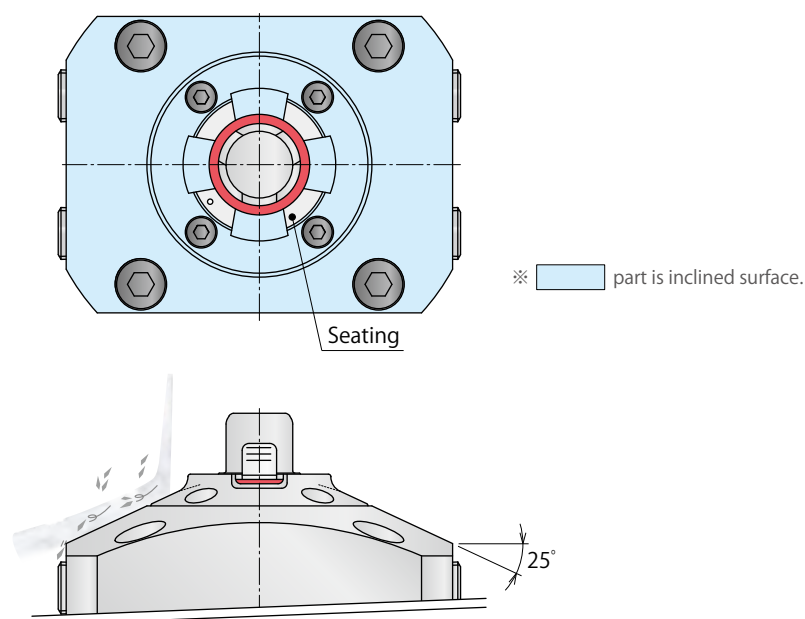

## ● Secure Clamp Action Out of Sight

Lift spring grips a workpiece strongly and pulls it in.※1

Even when air pressure is at zero, self-lock function with locking spring ensures safety.

※1. 'Without pulling function' (option) does not pull down the workpiece to the seating surface.

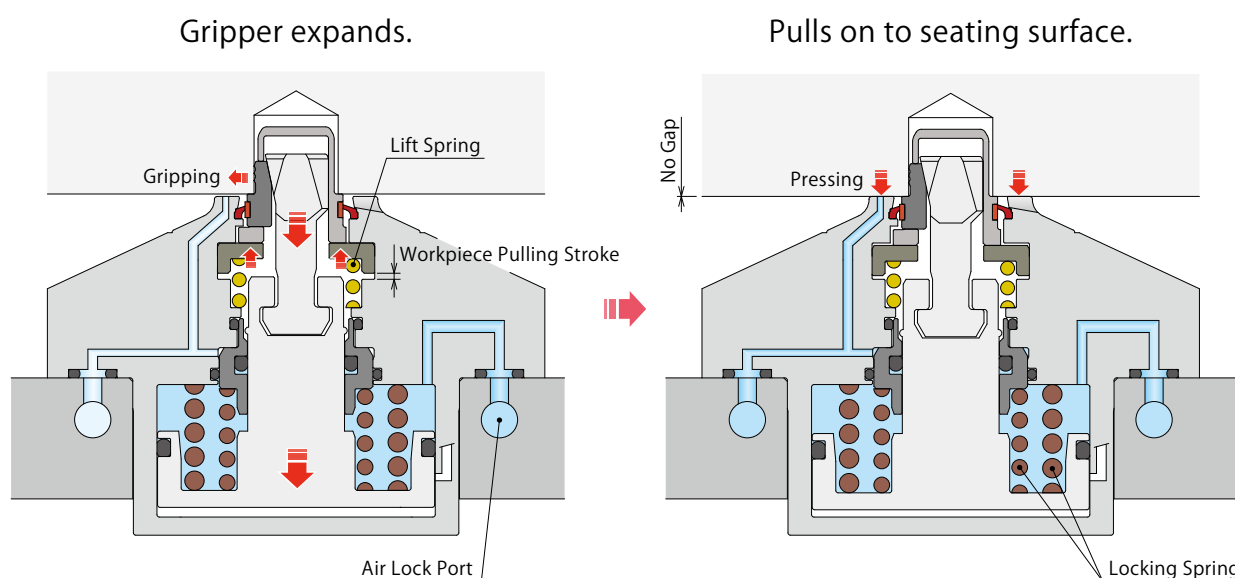

※This is a simplified drawing. Actual components are different.

● Features

● Action Confirmation of Clamping

Lift-up function allows to check the movement of pulling and lifting off the workpiece. It can be used in automated line.

※ Lift-up function is the function of "workpiece lifting option: with lift option".

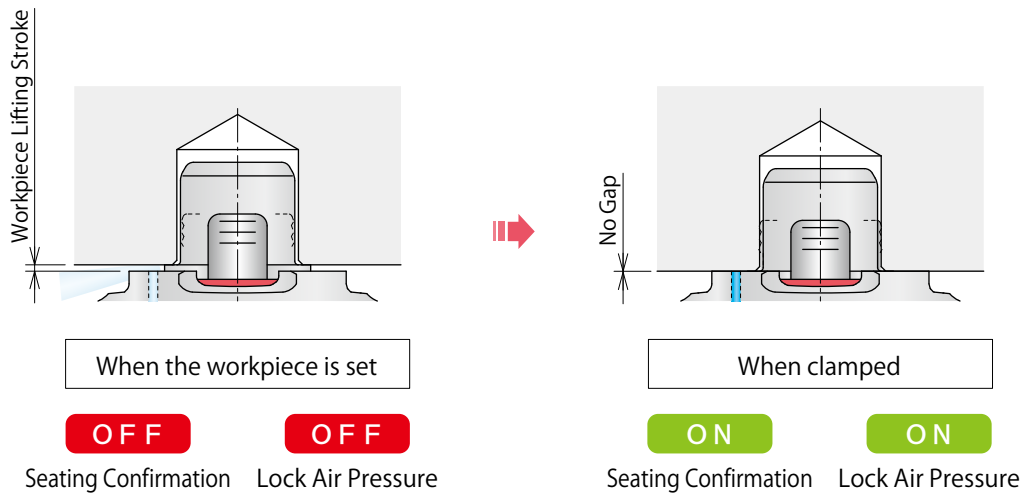

● Abnormality Detection for Unpredictable Troubles

Error detection for unpredictable troubles when machining or transferring. It can be used in automated line.

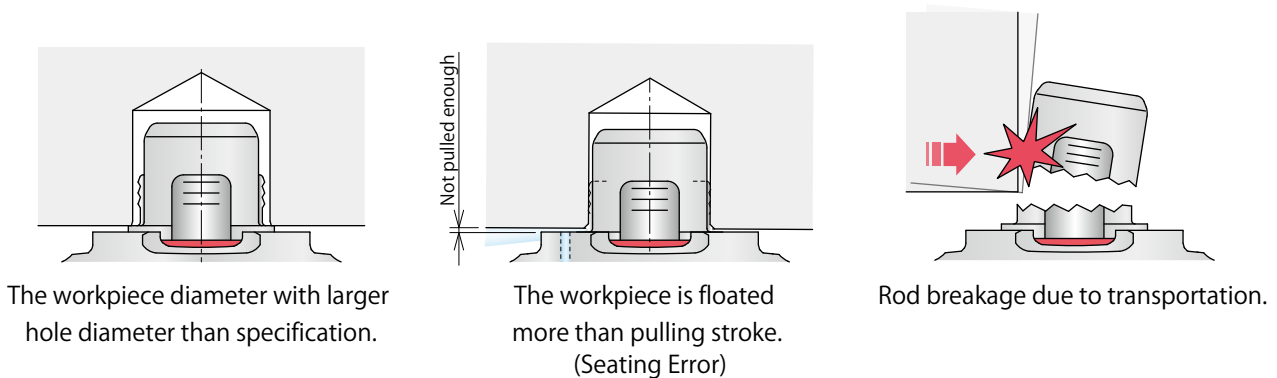

## Action Description

※This is a simplified drawing. Actual components are different.

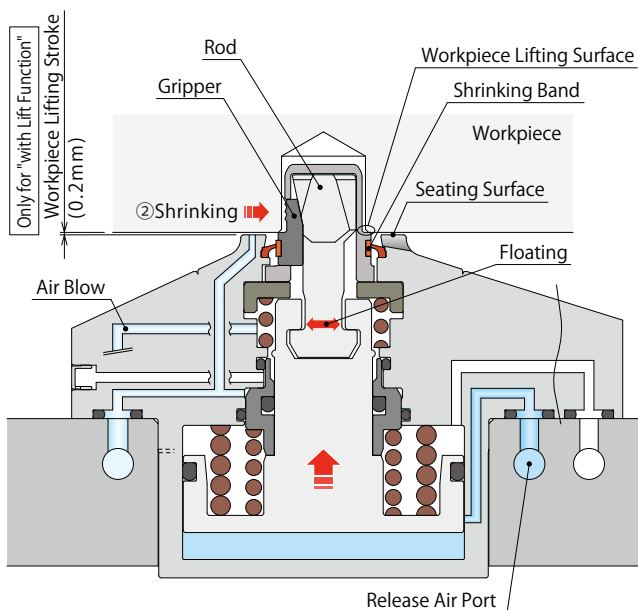

### Released State

- ① Air pressure is supplied to the release port.
- ↓
- ② The rod is lifted up and the gripper retracts.  
(For workpiece lifting option, there is a gap between workpiece bottom surface and seating surface.)

Air Pressure Switch		Seat Check Detection (Air Sensor)
Release Air Pressure	Lock Air Pressure	
<b>ON</b>	OFF	<b>OFF</b>

※ Continuously supply air pressure to the air blow port and seating confirmation port. If clamps are used without air supply, foreign substances enter into clamps resulting in clamping error.  
Option : Without Pulling Function has no seating confirmation detection and only detects abnormality shown below.

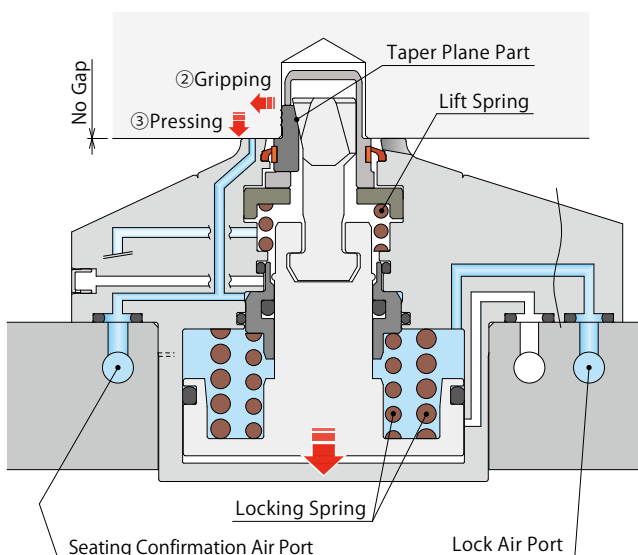

### Locked State

- ① Air pressure is supplied to the lock port.
- ↓
- ② The rod descends and the gripper expands along the taper plane. (Since the gripper is lifted by spring force, it does not pull down.)
- ↓
- ③ When pulling force exceeds the spring force for lift up, pulling force works after the gripper digs into workpiece. Then, it presses workpiece onto seating surface. (Clamping force = Pressing force onto seating surface.)

Air Pressure Switch		Seat Check Detection (Air Sensor)
Release Air Pressure	Lock Air Pressure	
OFF	<b>ON</b>	<b>ON</b>

( Without Pulling Function (Option) clamps a workpiece )  
with expansion of grippers. There is no action of ③.

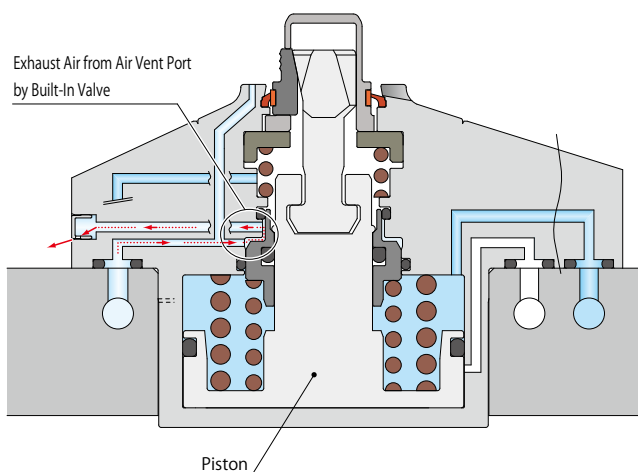

### Abnormality Detected State (Clamping without Workpiece)

The built-in check valve function and seating confirmation air pressure detect abnormal condition as follows.

- When clamping workpiece which has larger workpiece hole diameter or clamping without workpiece (In this state the gripper expands but the lifting spring does not have pulling force so the workpiece lifting surface does not descend.)
- When rod or gripper is broken.
- If the piston is fully stroked when it has to stop at the bottom.
- In the case workpiece is floated more than 1mm when setting it.

Air Pressure Switch		Seat Check Detection (Air Sensor)
Release Air Pressure	Lock Air Pressure	
OFF	<b>ON</b>	<b>OFF</b>

High-Power Series

Pneumatic Series

Hydraulic Series

Valve / Coupler Hydraulic Unit

Manual Operation Accessories

Cautions / Others

Pneumatic Hole Clamp

SWA

Pneumatic Swing Clamp

WHA

Double Piston Pneumatic Swing Clamp

WHD

Pneumatic Link Clamp

WCA

Air Flow Control Valve

BZW

Pneumatic Expansion Locating Pin

VWM

VWK

Pneumatic Sensor Pin

WWA

Model No. Indication (Workpiece Hole Shape : Straight)

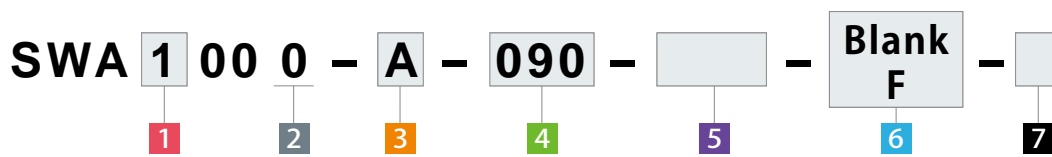

**1 Body Size** ※ Please refer to specifications, performance curve and external dimensions for details.

- 1 : Available in diameters between  $\phi 6$  and  $\phi 9$ mm
- 2 : Available in diameters between  $\phi 9$  and  $\phi 13$ mm

**2 Design No.**

0 : Revision Number

**3 Workpiece Lifting Option**

- A : With Lifting Function (Workpiece Lifting Option)
- N : Without Lifting Function

The lifting function lifts the workpiece 0.2mm up from the seating surface when the clamp is released.

Note : When using SWA with expansion locating pin(s) (model VWH, VWM, VWK, VFH, VFL, VFM, VFJ, VFK, VX), please choose **N** : Without Lifting Function.

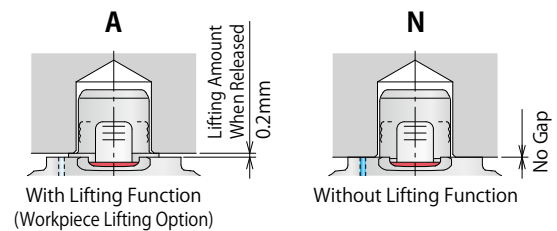

**4 Workpiece Hole Diameter (Workpiece Hole Code)**

**Workpiece Hole Code** : Workpiece Hole Diameter  $\phi d$

- ※ Workpiece hole diameter should be specified in 0.5mm increments from the allowable range in the following table.
- ※ Refer to the specifications for the tolerance.

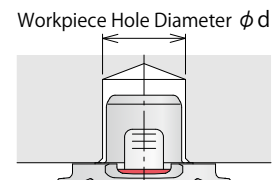

Workpiece Hole Code	060	065	070	075	080	085	090	095	100	105	110	115	120	125	130	
Workpiece Hole Diameter $\phi d$ (mm)	6	6.5	7	7.5	8	8.5	9	9.5	10	10.5	11	11.5	12	12.5	13	
<b>SWA1000</b>	▲	▲	Allowable Range													
<b>SWA2000</b>							Allowable Range									

※ Maximum operating pressure for the workpiece hole diameters marked ▲ : 0.5MPa.

## 5 Seating Height Dimension

**Blank** : Standard Height (30mm)

**H** **Seating Height** : Specifying Seating Height (In 5mm increments)

Model	Seating Height H (mm)								
	Standard	30	35	40	45	50	55	60	
<b>SWA1000</b>	30	★	H□ Range						
<b>SWA2000</b>	30	★	H□ Range						

※ ★ part is standard height, and seating height dimension code is "Blank".

※ Entry example when specifying non-standard seating height.  
In case of seating height 50mm : **H50**

H□ Seating Height  
H35 : 35  
H40 : 40  
H45 : 45  
H50 : 50  
H55 : 55  
H60 : 60

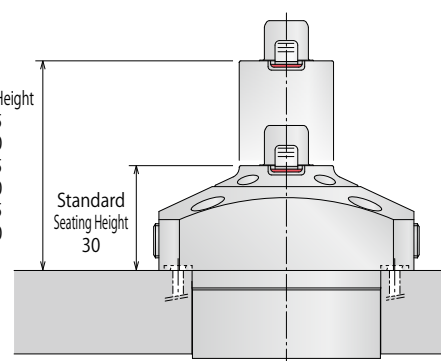

## 6 Workpiece Hole (Gripper) Shape

**Blank** : With Serration (Workpiece Hole Shape: Straight)

**F** : Without Serration (Workpiece Hole Shape: Straight)

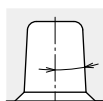
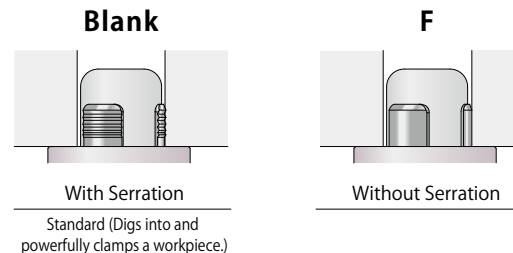

Slope Angle  
Less than 3°

**Refer to P.239 ~ P.240 for the taper workpiece hole.**

※ Contact us when ordering the taper hole model.

Taper Hole

## 7 Option

**Blank** : Standard Model (With Pulling Function)

**W** : Without Pulling Function ※2 ※3

※2. It has no air blow-out hole for seating confirmation or its function.  
With built-in valve it detects clamp abnormality except seating confirmation.

※3. **3** Workpiece lifting function is **N**.

Air Blow-out Hole for  
Seating Confirmation  
Not Equipped for **W**

Lift Spring

Not Equipped for **W**

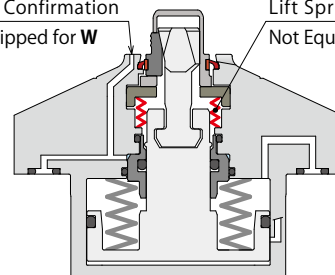



## 5 Seating Height Dimension

**Blank** : Standard Height (30mm)

**H Seating Height** : Specifying Seating Height (In 5mm increments)

Model	Seating Height H (mm)							
	Standard	30	35	40	45	50	55	60
<b>SWA1000</b>	30	★						
<b>SWA2000</b>	30	★						

※ ★ part is standard height, and seating height dimension code is "**Blank**".

※ Entry example when specifying non-standard seating height.  
In case of seating height 50mm : **H50**

H □ Seating Height  
 H35 : 35  
 H40 : 40  
 H45 : 45  
 H50 : 50  
 H55 : 55  
 H60 : 60

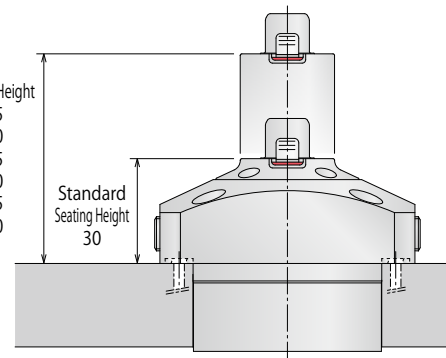

## 6 Workpiece Hole (Gripper) Shape

**T** : Taper Hole (with Serration)

When ordering this model, please inform us of the detailed dimensions of the workpiece hole.

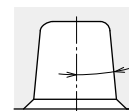

Slope Angle  
Less than 3°

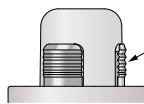

With Serration

Standard (Digs into and powerfully clamps a workpiece.)

Workpiece Hole Shape : Taper Hole (with Serration)

(\*No Serration\* is not available.)

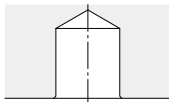

Hole Shape: Straight

Refer to P.237 ~ P.238 for the straight workpiece hole.

Specifications (Workpiece Hole Shape : Straight)

Applicable Model No.

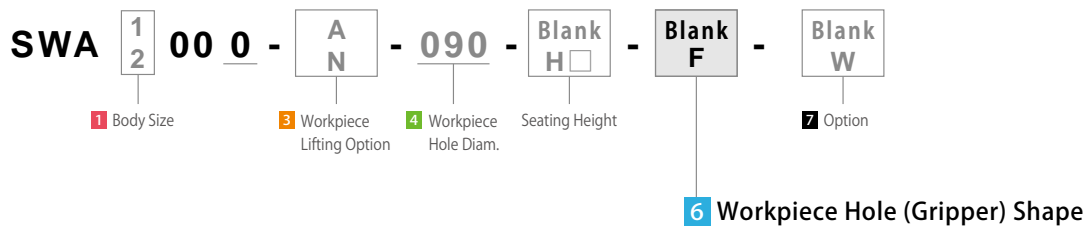

Model No.	SWA1000 -□-□-□-□ SWA1000 -□-□-□-□-□								SWA2000 -□-□-□-□ SWA2000 -□-□-□-□-□								
	4 Workpiece Hole Code	060	065	070	075	080	085	090	090	095	100	105	110	115	120	125	130
Workpiece Hole	3 Lifting Option A	6 <sup>±0.3</sup>	6.5 <sup>±0.3</sup>	7 <sup>±0.3</sup>	7.5 <sup>±0.3</sup>	8 <sup>±0.3</sup>	8.5 <sup>±0.3</sup>	9 <sup>±0.3</sup>	9 <sup>+0.7</sup>	9.5 <sup>+0.7</sup>	10 <sup>+0.7</sup>	10.5 <sup>+0.7</sup>	11 <sup>+0.7</sup>	11.5 <sup>+0.7</sup>	12 <sup>+0.7</sup>	12.5 <sup>+0.7</sup>	13 <sup>+0.7</sup>
Diam. φd	3 Lifting Option N	6 <sup>+0.7</sup>	6.5 <sup>+0.7</sup>	7 <sup>+0.7</sup>	7.5 <sup>+0.7</sup>	8 <sup>+0.7</sup>	8.5 <sup>+0.7</sup>	9 <sup>+0.7</sup>	9 <sup>-0.3</sup>	9.5 <sup>-0.3</sup>	10 <sup>-0.3</sup>	10.5 <sup>-0.3</sup>	11 <sup>-0.3</sup>	11.5 <sup>-0.3</sup>	12 <sup>-0.3</sup>	12.5 <sup>-0.3</sup>	13 <sup>-0.3</sup>
Workpiece Hardness		HB250 or less															
Allowable Offset (Floating Clearance of Expanding Area) <sup>※1</sup>	mm	±0.3								±0.5							
Full Stroke	mm	4.2															
Workpiece	7 Option Blank	1.0															
Pulling Stroke	7 Option W	0.1 or less															
Workpiece Lifting Stroke <sup>※2</sup> (Only for 3 A)	mm	0.2															
Workpiece Lifting Force <sup>※2</sup> (Only for 3 A)	kN	0.09								0.15							
Cylinder Capacity (Empty Action)	Release	4.8								7							
	Lock	4.3								6.1							
Max. Operating Pressure	MPa	0.5	0.7									0.7					
Min. Releasing Pressure	MPa	0.25															
Withstanding Pressure	MPa	0.75	1.0									1.0					
Recommended Air Blow Pressure	MPa	0.2 ~ 0.3															
Operating Temperature	°C	0 ~ 70															
Usable Fluid		Dry Air															
Weight		Please refer to the external dimensions for the product weight.															

Notes:

※1. The clamping part is an adjusting structure and the clamping operation is done by locating the workpiece hole. The numerical value in the table shows the amount of tolerance value of single clamp. Please consider the center distance accuracy of each clamping installation part and each workpiece hole when used with another location clamp / location cylinder, or when using more than two of these products.

※2. Workpiece lifting stroke and workpiece lifting force are functions only for lifting option.



Performance Curve (Option **7** Blank : Standard)

Applicable Model No.

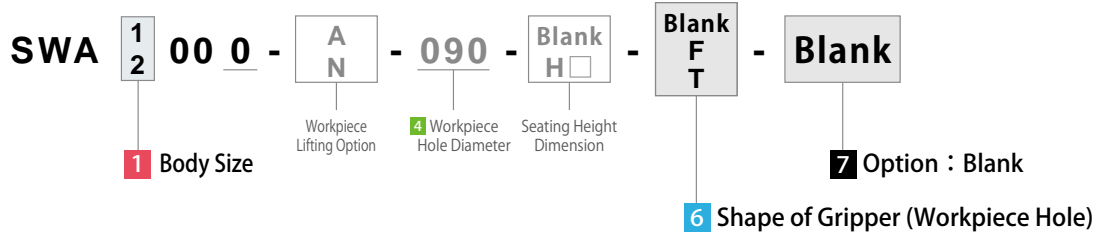

Clamping Force Curve

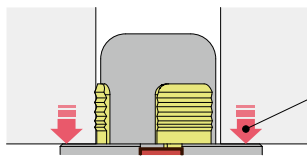

Clamping Force

It shows the pressing force against the seating surface.

Model No.	Clamping Force (kN)										
	6 Blank / T : With Serration			6 F : Without Serration							
4 Workpiece Hole Code	SWA1000-□-□-□	SWA1000-□-□-□-090	SWA1000-□-□-□-090	SWA2000-□-□-□-090~130	SWA2000-□-□-□-090~130	SWA2000-□-□-□-090~130					
Air Pressure 0.7 MPa	-	-	0.75	-	-	0.75	1.1	-	-	0.21	0.30
Air Pressure 0.6 MPa	-	-	0.65	-	-	0.65	0.95	-	-	0.19	0.26
Air Pressure 0.5 MPa	0.55		-	0.55		0.80	0.16		0.22		
Air Pressure 0.4 MPa	0.45		-	0.45		0.65	0.13		0.18		
Air Pressure 0.3 MPa	0.35		-	0.35		0.50	0.11		0.14		
Air Pressure 0.25 MPa	0.30		-	0.30		0.45	0.10		0.12		
Air Pressure 0 MPa	0.10		-	0.10		0.10	0.02		0.03		
Clamping Force Calculation Formula <sup>※1</sup> kN	Fc = 0.93P + 0.1		-	Fc = 0.93P + 0.1		Fc = 1.43P + 0.1	Fc = 0.27P + 0.02		Fc = 0.39P + 0.03		

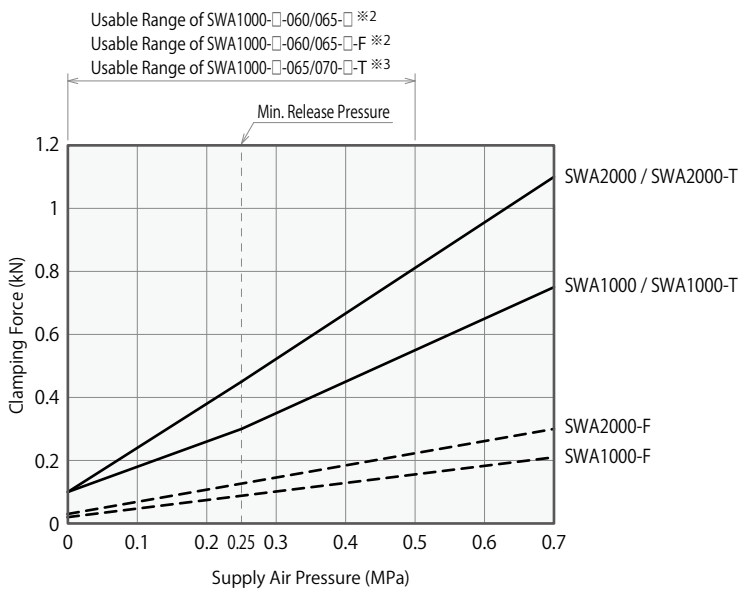

Notes:

- The table and graph show the relationship between clamping force (kN) and supply air pressure (MPa).
- Clamping force shows a pressing force against the seating surface.
- Thin wall around the workpiece hole can be deformed by clamping action, and the clamping force will not fill the specification.
- Clamping force of **F**: Without Serration shows the calculated value when the friction coefficient of workpiece and gripper is  $\mu 0.1$ .

※1. Fc: Clamping Force (kN), P: Supply Air Pressure (MPa)

※2. When selecting SWA1000-□-□-□, SWA1000-□-□-□-F with workpiece hole code **060 / 065**, it cannot be used with 0.5MPa or more.

※3. When selecting SWA1000-□-□-□-T with workpiece hole code **065 / 070**, it cannot be used with 0.5MPa or more.

## Performance Curve (Option **W** : Without Pulling Function)

Applicable Model No.

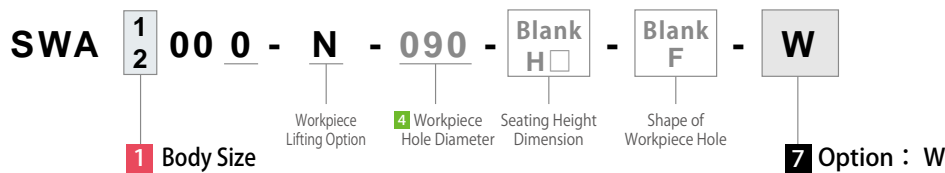

### Expanding Force Curve

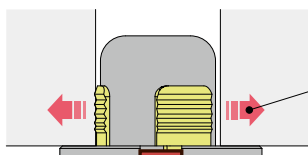

### Expanding Force

It shows the gripping force generated inside workpiece hole.

Model No.	Expanding Force (kN)			
	SWA1000-N-□-□- <b>W</b>		SWA2000-N-□-□- <b>W</b>	
	SWA1000-N-□-□- <b>F-W</b>		SWA2000-N-□-□- <b>F-W</b>	
<b>4</b> Workpiece Hole Code	<b>060</b>	<b>065</b>	<b>070 ~ 090</b>	<b>090 ~ 130</b>
Air Pressure 0.7 MPa	-	-	2.4	3.5
Air Pressure 0.6 MPa	-	-	2.1	3.1
Air Pressure 0.5 MPa			1.9	2.7
Air Pressure 0.4 MPa			1.6	2.3
Air Pressure 0.3 MPa			1.3	1.9
Air Pressure 0.25 MPa			1.1	1.7
Air Pressure 0 MPa			0.50	0.75
Expanding Force Calculation Formula <sup>※4</sup> kN	Fc = 2.71P + 0.5		Fc = 3.89P + 0.75	

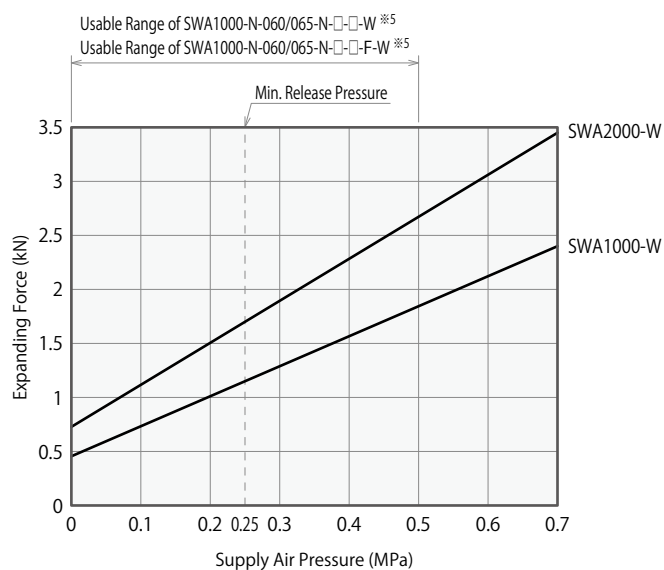

#### Notes:

- The table and graph show the relationship between expanding force (kN) and supply air pressure (MPa).
  - Expanding force shows the gripping force generated inside workpiece hole.
  - Expanding force shows the calculated value when the friction coefficient of expanding part is  $\mu 0.15$ .
  - Thin wall around the workpiece hole can be deformed by expanding action, and expanding force will not fill the specification.
  - 0.1mm or less pulling stroke can be generated by accumulated tolerance of internal parts.
- ※4. Fh: Expanding Force (kN), P : Supply Air Pressure (MPa)
- ※5. When selecting SWA1000-N-□-□-**W**, SWA1000-N-□-□-**F-W** with workpiece hole code **060 / 065**, it cannot be used with 0.5MPa or more.

High-Power  
Series

Pneumatic Series

Hydraulic Series

Valve / Coupler  
Hydraulic Unit

Manual Operation  
Accessories

Cautions / Others

Pneumatic  
Hole Clamp

SWA

Pneumatic  
Swing Clamp

WHA

Double Piston  
Pneumatic Swing Clamp

WHD

Pneumatic  
Link Clamp

WCA

Air Flow  
Control Valve

BZW

Pneumatic  
Expansion Locating Pin

VWM

VWK

Pneumatic Sensor Pin

WWA

External Dimensions

※This drawing shows the released state of SWA1000-A-□.

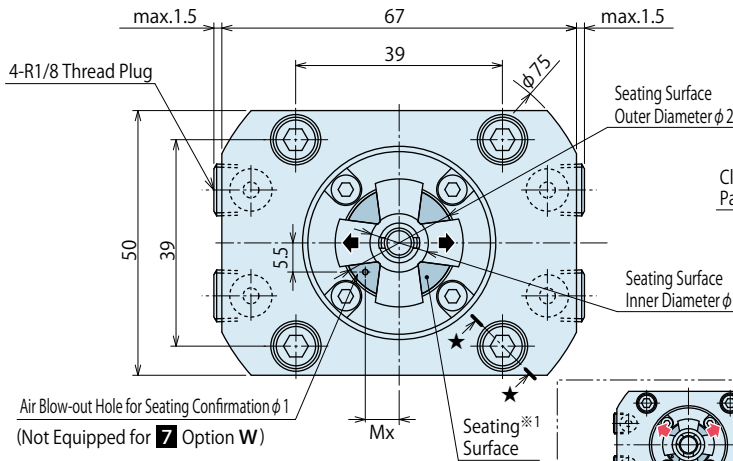

Expanding Area Detail

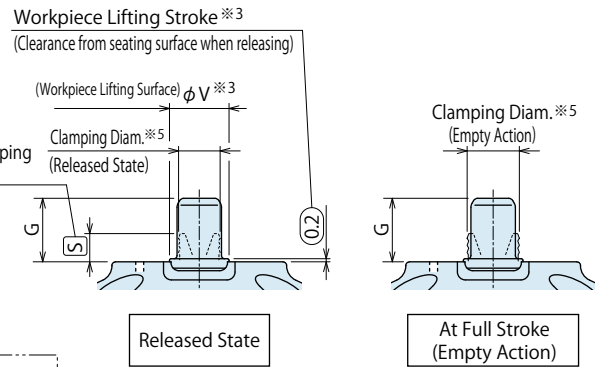

Seating Height: Standard

SWA1000-□-090: Gripper Expanding Direction shows the expanding direction of the gripper.

Workpiece Hole (Gripper Shape): T

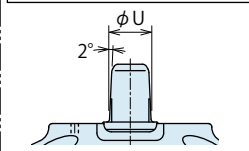

4-Mounting Bolt (Included) M5×0.8×20

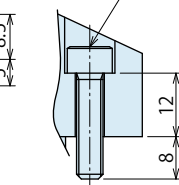

Cross Section ★-★

SWA1000-□-060 ~ 085: 2 Grippers 180° Distance

SWA1000-□-090 : 3 Grippers 120° Distance

◆ shows the expanding direction of the gripper. (The direction of gripper is as indicated in this drawing.)

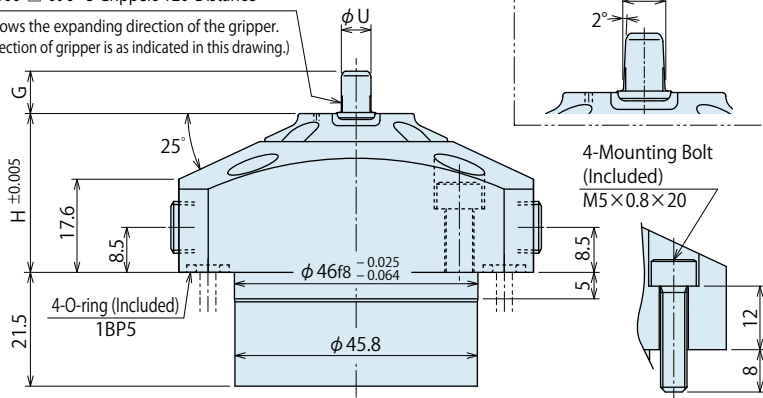

Specifying Seating Height

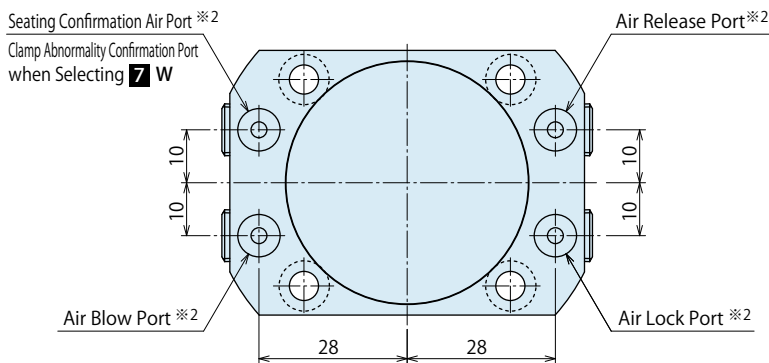
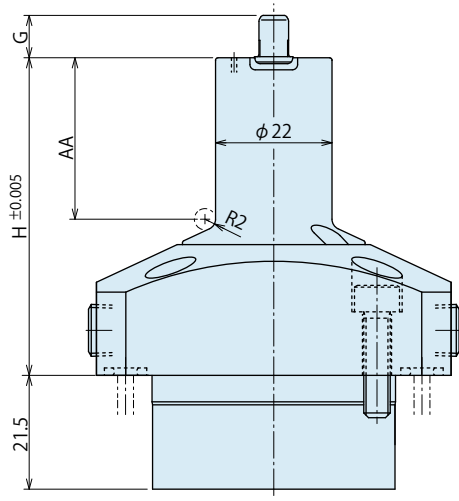

Workpiece (Pallet) Hole Dimensions

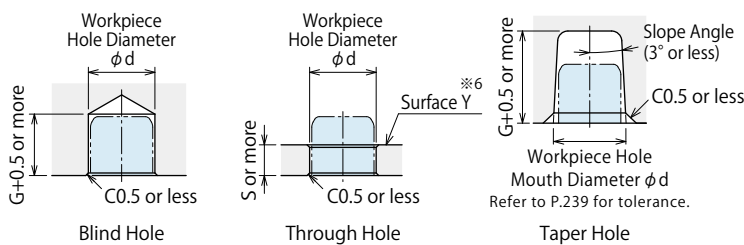

Notes:

- ※1. The workpiece must be resting on all seating surfaces when clamping. If this is not done the workpiece can be deformed by the clamping force.
- ※2. The port names are marked on the product surface. (LOCK: Air Lock Port, RELEASE: Air Release Port, BLOW: Air Blow Port, FC: Seating Confirmation Port, SENSOR: Clamp Abnormality Confirmation Port) Continuously supply air pressure to the air blow port, and the seating confirmation port or clamp abnormality confirmation port.
- ※3. The numerical value is only for the workpiece lifting option.
- ※4. Please refer to Seating Height: Standard for unlisted dimensions.
- ※5. For -T: Taper Hole model, the first gripper ridge is the reference diameter.

Notes:

- 1. Workpiece hole that is extremely thin can be deformed by clamping action and the specifications will not be fulfilled. Please make sure to test the clamping function before using and adjust to the appropriate supply of pressure.
- ※6. When the clamp head is sticking above the surface Y of the workpiece, please make sure there is no interference with the clamp cylinders during machining.

## Machining Dimensions of Mounting Area

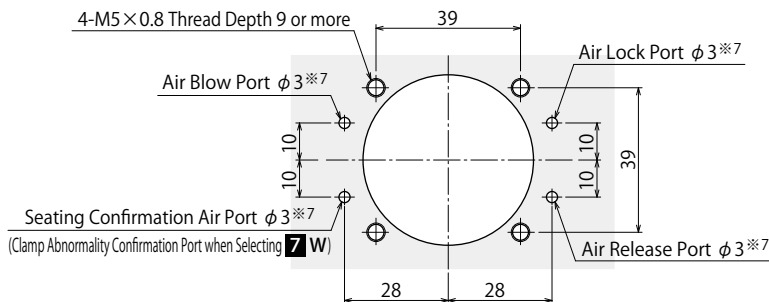

Through Hole

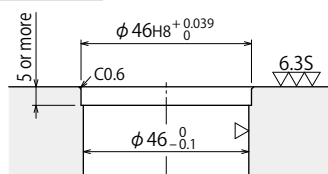

Blind Hole

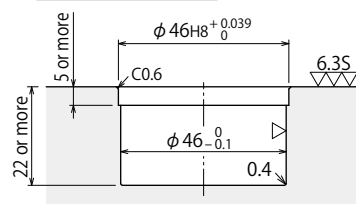

### Notes:

1. There should be no burrs at the hole contact surface.

※7. It is not required to machine each port if removing SWA R1/8 thread plug (4 plugs) and setting air fitting and air hose directly.

## Model No. Indication

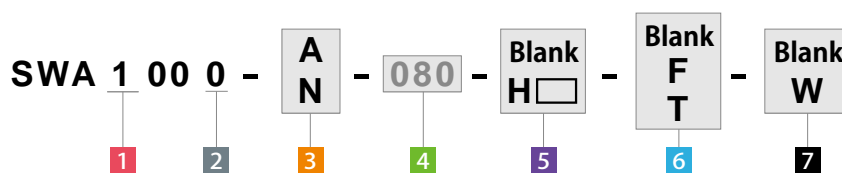

1 Body Size (When selecting 1)

2 Design No.

3 Workpiece Lifting Option

4 Workpiece Hole Diameter (Workpiece Hole Code)

5 Seating Height Dimension

6 Shape of Gripper (Workpiece Hole)

7 Option

## External Dimensions and Machining Dimensions for Mounting (mm)

Model No.	SWA1000-□-□-□-□-□							
4 Workpiece Hole Code	060	065	070	075	080	085	090	
Workpiece Hole	3 Lifting Option A ※10	6 ±0.3	6.5 ±0.3	7 ±0.3	7.5 ±0.3	8 ±0.3	8.5 ±0.3	9 ±0.3
Diam. φ d ※10	3 Lifting Option N ※10	6 +0.7/-0.3	6.5 +0.7/-0.3	7 +0.7/-0.3	7.5 +0.7/-0.3	8 +0.7/-0.3	8.5 +0.7/-0.3	9 +0.7/-0.3
Clamping Diameter	Released State	5.5	6	6.5	7	7.5	8	8.5
	Empty Action	7.2	7.7	8.2	8.7	9.2	9.7	10.2
Allowable Offset (Floating Clearance of Expanding Area) ※8								±0.3
Full Stroke								4.2
Workpiece	7 Option Blank							1.0
Pulling Stroke	7 Option W							0.1 or less
Workpiece Lifting Stroke ※9 (Only for 3 A)								0.2
6 Shape of Gripper Blank, F	G	8	8	8	8	8	8	9.5
	S	3.3	3.3	3.3	3.3	3.3	3.3	4.3
	U	5.6	6.1	6.6	7.1	7.6	8.1	8.6
6 Shape of Gripper T	G	-	8	8	8	8	8	9.5
	S	-	3.3	3.3	3.3	3.3	3.3	4.3
	U	-	6	6.5	7	7.5	8	8.6
Mx		6.4	6.4	6.4	6.4	6.4	7	7.6
V		7.5	8	8.5	9	9.5	10	11.5
W		11	12	12	13	13	14	15

Notes : ※ 8. The clamping part is an adjusting structure and the clamping operation is done by locating the workpiece hole. The numerical value in the table shows the amount of tolerance value of single clamp. Please consider the center distance accuracy of each clamping installation part and each workpiece hole when used with other location clamps / location cylinders, or when using more than two of these products.

※ 9. Workpiece lifting stroke is the function only for lifting option.

※ 10. For -T: Taper Hole model, the allowable tolerance of the hole mouth diameter differs depending on the slope angle. (Refer to P.239)

5 Seating Height Dimension	Standard Height	Specifying Seating Height					
	Blank	H35	H40	H45	H50	H55	H60
H	30	35	40	45	50	55	60
AA	-	5.5	10.5	15.5	20.5	25.5	30.5
Weight kg	0.7	0.7	0.7	0.7	0.7	0.75	0.75

High-Power Series

Pneumatic Series

Hydraulic Series

Valve / Coupler Hydraulic Unit

Manual Operation Accessories

Cautions / Others

Pneumatic Hole Clamp

SWA

Pneumatic Swing Clamp

WHA

Double Piston Pneumatic Swing Clamp

WHD

Pneumatic Link Clamp

WCA

Air Flow Control Valve

BZW

Pneumatic Expansion Locating Pin

VWM

VWK

Pneumatic Sensor Pin

WWA



## Machining Dimensions of Mounting Area

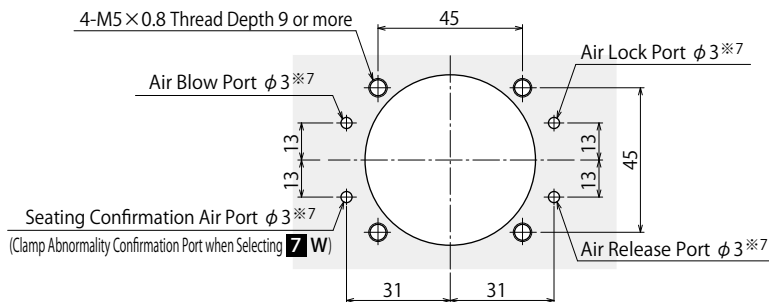

Through Hole

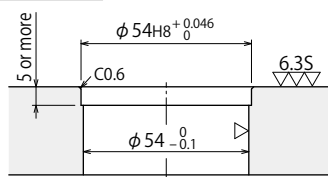

Blind Hole

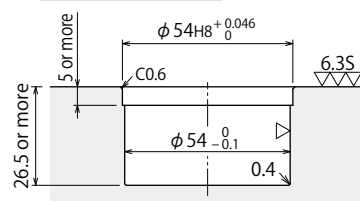

### Notes:

1. There should be no burrs at the hole contact surface.

※7. It is not required to machine each port if removing SWA R1/8 thread plug (4 plugs) and setting air fitting and air hose directly.

## Model No. Indication

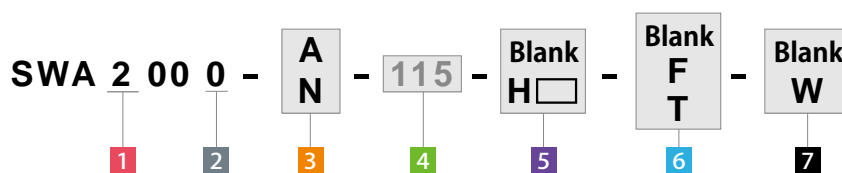

1 Body Size (When selecting 2)

2 Design No.

3 Workpiece Lifting Option

4 Workpiece Hole Diameter (Workpiece Hole Code)

5 Seating Height Dimension

6 Shape of Gripper (Workpiece Hole)

7 Option

## External Dimensions and Machining Dimensions for Mounting

(mm)

Model No.		SWA2000-□-□-□-□-□								
4 Workpiece Hole Code		090	095	100	105	110	115	120	125	130
Workpiece Hole Diam. $\phi d$	6 Blank, F ※10	$9^{+0.7}_{-0.3}$	$9.5^{+0.7}_{-0.3}$	$10^{+0.7}_{-0.3}$	$10.5^{+0.7}_{-0.3}$	$11^{+0.7}_{-0.3}$	$11.5^{+0.7}_{-0.3}$	$12^{+0.7}_{-0.3}$	$12.5^{+0.7}_{-0.3}$	$13^{+0.7}_{-0.3}$
Clamping Diameter	Released State	8.5	9	9.5	10	10.5	11	11.5	12	12.5
	Empty Action	10.2	10.7	11.2	11.7	12.2	12.7	13.2	13.7	14.2
Allowable Offset (Floating Clearance of Expanding Area) ※8						±0.5				
Full Stroke						4.2				
Workpiece Pulling St. ※9	7 Option Blank	1.0								
	7 Option W	0.1 or less								
Workpiece Lifting Stroke ※9 (Only for 3 A)						0.2				
6 Shape of Gripper Blank, F	G	10	10	10	11.5	11.5	11.5	11.5	11.5	11.5
	S	4.3	4.3	4.3	5.8	5.8	5.8	5.8	5.8	5.8
	U	8.6	9.1	9.6	10.1	10.6	11.1	11.6	12.1	12.6
6 Shape of Gripper T	G	10	10	10	10	11.5	11.5	11.5	11.5	11.5
	S	4.3	4.3	4.3	4.3	5.8	5.8	5.8	5.8	5.8
	U	8.6	9	9.5	10	10.4	10.9	11.4	11.9	12.4
	Mx	8	8	8	8	8	8.6	8.6	9.3	9.3
	R	R2	R2	R2	R3	R3	R3	R3	R3	R3
	V	11.5	12	12.5	13	13.5	14	14.5	15	15.5
	W	15	16	16	17	17	18	18	19	19
	X	24	24	24	24	24	25	25	26	26
	Y	25	25	25	25	25	26	26	27	27

Notes: ※ 8. The clamping part is an adjusting structure and the clamping operation is done by locating the workpiece hole. The numerical value in the table shows the amount of tolerance value of single clamp. Please consider the center distance accuracy of each clamping installation part and each workpiece hole when used with other location clamps / location cylinders, or when using more than two of these products.

※ 9. Workpiece lifting stroke is the function only for lifting option.

※ 10. For -T: Taper Hole model, the allowable tolerance of the hole mouth diameter differs depending on the slope angle. (Refer to P.239.)

(mm)

5 Seating Height Dimension	Standard Height	Specifying Seating Height					
	Blank	H35	H40	H45	H50	H55	H60
H	30	35	40	45	50	55	60
AA	-	5.5	10.5	15.5	20.5	25.5	30.5
Weight kg	1.0	1.0	1.0	1.0	1.1	1.1	1.1

High-Power Series

Pneumatic Series

Hydraulic Series

Valve / Coupler Hydraulic Unit

Manual Operation Accessories

Cautions / Others

Pneumatic Hole Clamp

SWA

Pneumatic Swing Clamp

WHA

Double Piston Pneumatic Swing Clamp

WHD

Pneumatic Link Clamp

WCA

Air Flow Control Valve

BZW

Pneumatic Expansion Locating Pin

WVM

WVK

Pneumatic Sensor Pin

WWA

Layout Sample

※This drawing shows a combination mounting reference of SWA-N (Hole Clamp) and VWM (Expansion Locating Pin).

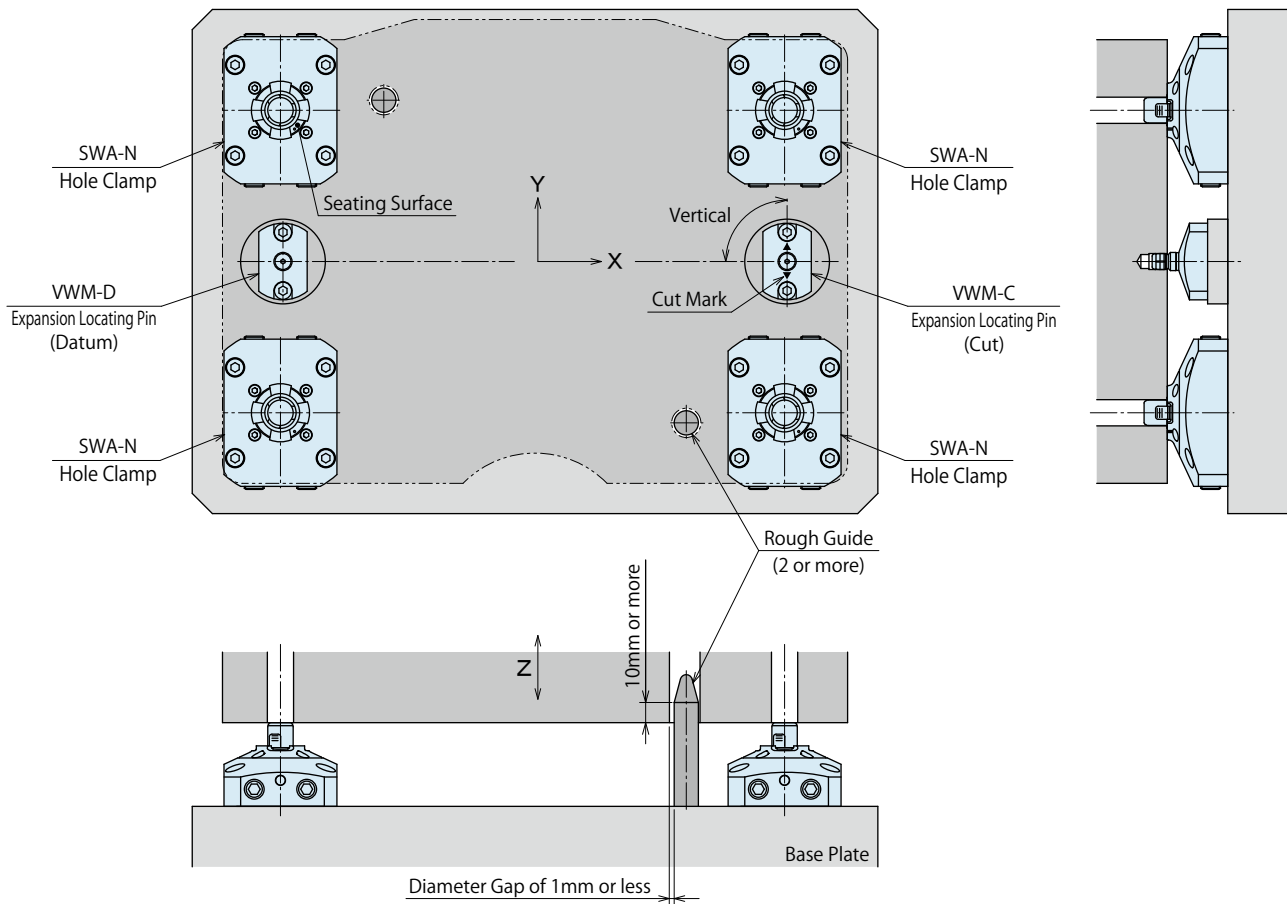

Notes:

1. In order to prevent the clamping part from damage, please set up rough guide of 2 or more when detaching a workpiece. Please refer to the above drawing for the length of rough guide and the diameter gap. (Use of rough guides depends on the loading / unloading condition of the workpiece.)
2. When using a combination of VWM (Expansion Locating Pin) and SWA (Hole Clamp), please choose N:Without lifting function.

## Pneumatic Circuit Reference

※ This drawing shows a combination circuit reference of SWA-N (Hole Clamp) and VWM (Pneumatic Expansion Locating Pin).

When controlled with one solenoid valve

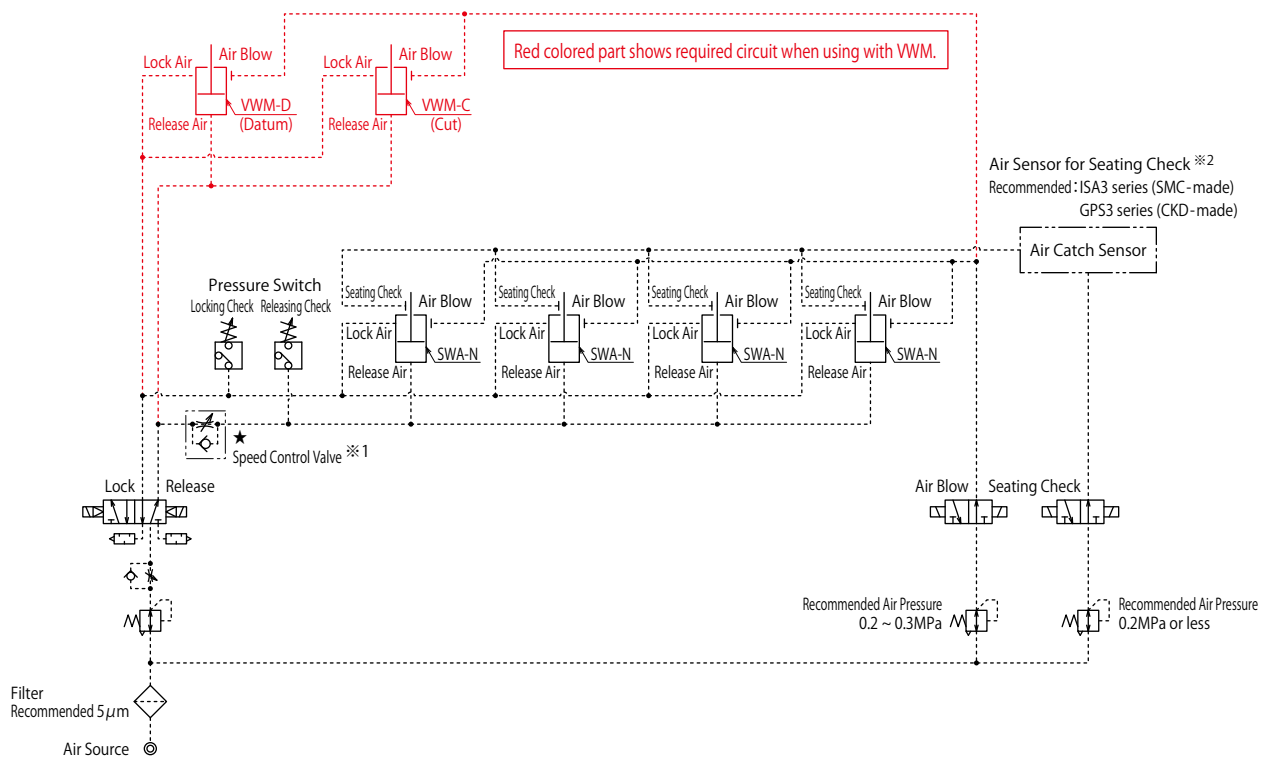

When controlled with two solenoid valves

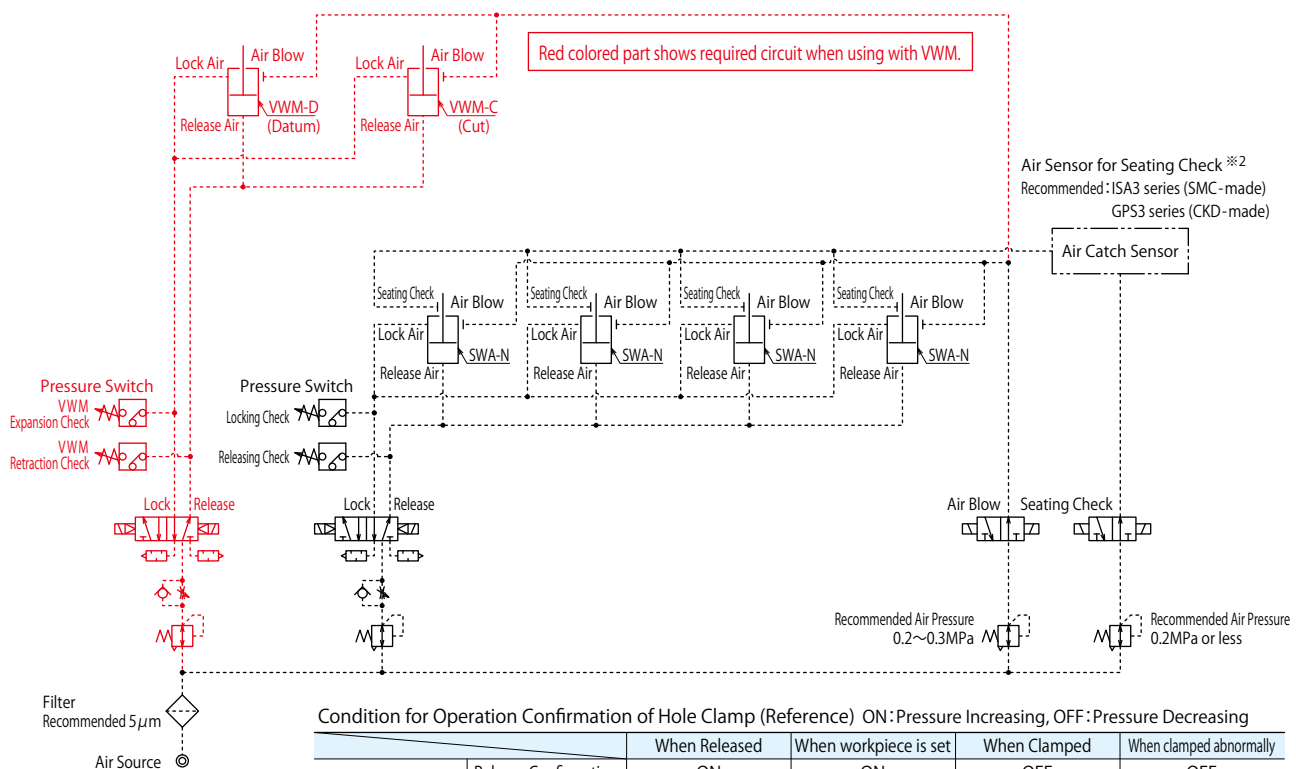

Condition for Operation Confirmation of Hole Clamp (Reference) ON: Pressure Increasing, OFF: Pressure Decreasing

		When Released	When workpiece is set	When Clamped	When clamped abnormally
Pressure Switch	Release Confirmation	ON	ON	OFF	OFF
	Lock Confirmation	OFF	OFF	ON	ON (OFF when air leaks)
Air Sensor for Seating Confirmation		OFF	ON (OFF) <sup>※3</sup>	ON	OFF

### Notes :

- ※1. Please use solenoid valve to make a sequence operation that SWA (hole clamp) starts working after VWM (Expansion Locating Pin) completes the movement. When unable to use solenoid valve, please prepare flow control valve with check valve at ★ (1 piece) to adjust sequencing speed. If SWA operates before VWM, there is a possibility for the product to be damaged due to a thrust load on SWA.
- ※2. In case high accuracy is required for air sensor setting, please install an air sensor for individual clamp.
- ※3. With lifting function it shows "OFF" since there is a gap between seating surface and workpiece. Without lifting function, it shows "ON" depending on set pressure of the air sensor.

High-Power Series

Pneumatic Series

Hydraulic Series

Valve / Coupler Hydraulic Unit

Manual Operation Accessories

Cautions / Others

Pneumatic Hole Clamp

SWA

Pneumatic Swing Clamp

WHA

Double Piston Pneumatic Swing Clamp

WHD

Pneumatic Link Clamp

WCA

Air Flow Control Valve

BZW

Pneumatic Expansion Locating Pin

VWM

VWK

Pneumatic Sensor Pin

WWA

**Cautions**

**Notes for Design**

- 1) Check Specifications
  - Please use each product according to the specifications.
  - This product is an air double-acting model which locks with air pressure and spring force, and releases with air pressure. Even when air is not supplied to either lock port or release port, built-in spring maintains locked condition (clamp diameter is expanded):
    - ① Maintains clamping force even when air pressure is at 0MPa. (Refer to the clamping force curve : clamping force at supply air pressure 0MPa on P.243).
    - ② Supply release air when loading/unloading a workpiece. If release air is not supplied, the workpiece contacts with the gripper leading to breakage of the workpiece and the clamp.

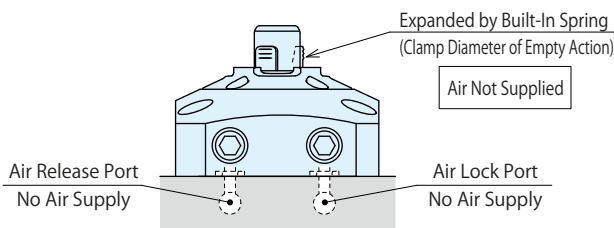

- 2) Working Reference Plate (Seating Surface) Z axis.
  - The upper surface of the flange of this product is the seating surface of workpiece and locates in Z direction.

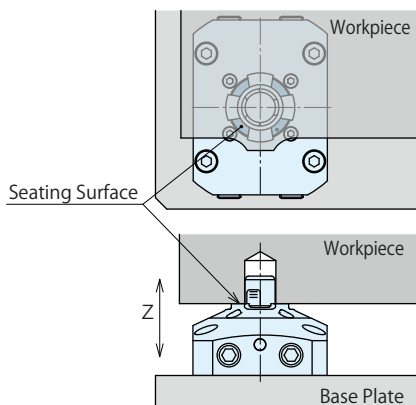

When clamping, make sure all seating surfaces touch a workpiece. When the workpiece is not touching the seating surface area, please refer to external dimension chart and calculate contacting pressure with clamping force and seating area not to deform the workpiece.

- 3) Seating Confirmation Mechanism
  - It will be detected when a workpiece is pressed against the seating surface by locking (clamping) action. (No seating confirmation for the option : without pulling function.)

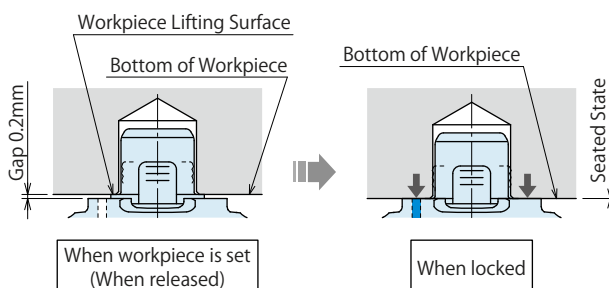

With lifting function, when a workpiece is set (before supplying lock air pressure), the workpiece is lifted by built-in spring, and there will be a gap of 0.2mm between workpiece bottom surface and seating surface.

- 4) Distance Accuracy of Clamp Mounting Hole and Workpiece Hole
  - The clamping part of this product has floating structure ( $\pm 0.3\text{mm}$  for SWA1000 and  $\pm 0.5\text{mm}$  for SWA2000 per clamp). Please consider the center distance accuracy of each clamping installation part and each workpiece hole when used with another location clamp / location cylinder, or when using more than two of these products.

- 5) Clamping Force and Expanding Force
  - Clamping force shows the pressing force against the seating surface. Expanding force shows the gripping force generated inside workpiece hole. Make sure to conduct test clamping and adjust supply pressure accordingly. Insufficient clamping force and/or expanding force leads to workpiece detachment.

- 6) Workpiece hole size, slope angle and workpiece hardness should be within the range of the specification.

When workpiece hole diameter is larger than specification.	Expansion stroke is insufficient and the clamping force • expanding force will not fill the specifications.
When using it with insufficient clamping force • expanding force.	Leads to falling of the workpiece.
When workpiece hole diameter is smaller than specification.	Difficult to attach/detach the workpiece leading to damage.
When workpiece hole depth is shallow.	Could lead to abnormal seating and damage.
When workpiece hole taper slope angle is larger than specification.	The load concentrates on the gripper point when clamping and could lead to damage.
When workpiece hole is harder than specified.	Gripper does not dig into the workpiece enough and it cannot clamp securely.

- 7) Wall Thickness around Workpiece Hole

- Thin wall around the workpiece hole could be deformed by clamping action, and clamping force/expanding force do not fill the specification. Please conduct clamping test and adjust to proper air pressure before use. Using with insufficient clamping force and expanding force leads to workpiece detachment.

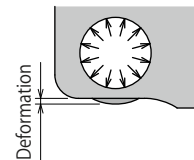

- 8) Air Blow Port and Seating Confirmation Port (Clamp Abnormality Confirmation Port)

- Continuously supply air pressure to the air blow port, and the seating confirmation port or clamp abnormality confirmation port. If air supply is shut off during operation, contaminants enter into the clamp leading to malfunctions.

## 9) Release Action

- When releasing, it lifts up the workpiece which is normal. When using in a horizontal application, it is recommended to install a fall prevention of workpiece for temporal tacking.

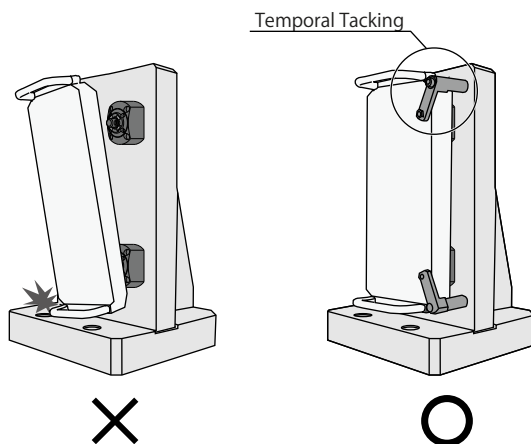

## 10) Horizontal Locating

- When a workpiece is set, please make sure there is no lifting or slope of the workpiece. If the clamping operation is done with lifting or slope of the workpiece, it will lead to possible damage of a clamp and deformation of the workpiece hole.

## 11) Please detach a workpiece with all clamps fully released.

- When a workpiece is detached during lock or release operation, it will lead to damage of clamp or fall of workpiece.

## 12) Please set up rough guides.

- When detaching a workpiece with slope it may cause the damage of clamp or fall of workpiece.

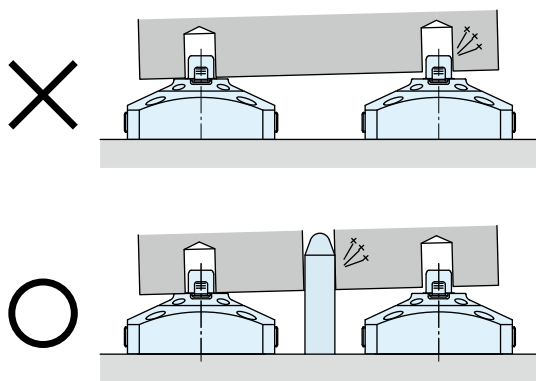

When using the product with other location clamps / cylinders, please set rough guides considering the center distance accuracy of each mounting hole and workpiece hole of location clamp / cylinders.

## 13) Damage Prevention during Robot Handling, etc.

- When inserting the SWA tip into/taking it out of a workpiece hole, the SWA tip has to be vertical to the workpiece hole. Especially after releasing a workpiece, the SWA tip must be fully taken out from the workpiece hole before moving to a next coordinate.

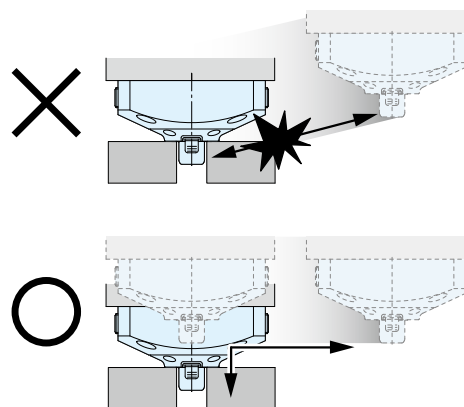

- If the SWA tip touches a workpiece when inserting, control the insertion speed to avoid damage on the workpiece and the SWA tip.

- When SWA is clamping/releasing a workpiece, make sure that the robot operates only after SWA completes clamping/releasing action by using a sensor or a timer. If the robot starts operating in the middle of clamping/releasing action, the workpiece may be fallen off.

- When clamping/releasing a workpiece, it may be tilted due to a gap between the workpiece and the stand. This causes damage of SWA. The gap has to be minimized as much as possible when clamping/releasing.

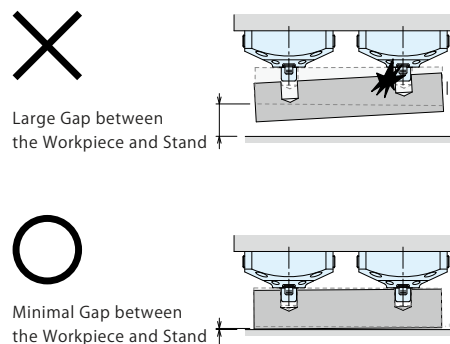

**Cautions**

**Installation Notes**

- 1) Check the Usable Fluid
  - Make sure to supply filtered clean dry air.
  - Oil supply with a lubricator etc. is unnecessary.
- 2) Procedure before Piping
  - The pipeline, piping connector and fixture circuits should be cleaned by thorough flushing. Dust and cutting chips in the circuit may lead to air leakage and malfunction.
  - There is no filter provided with this product to prevent contamination in the air circuit.
- 3) Applying Sealing Tape
  - Wrap with tape 1 to 2 times following the screw direction.
  - Pieces of the sealing tape can lead to air leakage and malfunction.
  - In order to prevent contamination during the piping work, it should be carefully cleaned before working.
- 4) Installation of the Product
  - When mounting the product, use all hexagonal socket bolts (with tensile strength of 12.9) and tighten them with the torque shown in the following table. Tighten them evenly to prevent twisting or jamming.

Model No.	Mounting Bolt Size	Tightening Torque (N·m)
SWA	M5×0.8	6.3

- 5) Port Position of the Hole Clamp
  - The port names are marked on the product surface. Be careful of installation direction. (LOCK : Air Lock Port, RELEASE : Air Release Port, FC : Seating Confirmation Port, BLOW : Air Blow Port, SENSOR : Clamp Abnormality Confirmation Port)
- 6) Use air piping with outer diameter  $\phi 6$  (inner diameter  $\phi 4$ ) or larger for air blow.
  - In order to conduct an effective air blow, it is recommended to use air piping with outer diameter  $\phi 6$  (inner diameter  $\phi 4$ ) or larger.

**Notes on Handling**

- 1) It should be operated by qualified personnel.
  - The hydraulic machine and air compressor should be operated and maintained by qualified personnel.
- 2) Do not operate or remove the product unless the safety protocols are ensured.
  - ① The machine and equipment can only be inspected or prepared when it is confirmed that the safety devices are in place.
  - ② Before the product is removed, make sure that the above-mentioned safety devices are in place. Shut off the pressure and power source, and make sure no pressure exists in the air and hydraulic circuits.
  - ③ After stopping the product, do not remove until the temperature drops.
  - ④ Make sure there is no abnormality in the bolts and respective parts before restarting the machine or equipment.
- 3) Do not touch workpieces (pallets) or clamps while they are working. Otherwise, your hands may be injured due to clinching.

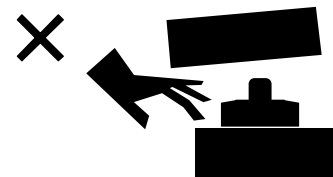

- 4) Do not disassemble or modify.
  - If the equipment is taken apart or modified, the warranty will be voided even within the warranty period.
  - Built-in spring is very strong and can be dangerous.

## ● Maintenance and Inspection

- 1) Please refer to P.1357 for general maintenance and inspection.
- 2) Regularly clean the clamping part and the seating surface.
  - There is an air blow mechanism in this product, and cutting chips and coolant can be removed. However, as it may be hard to remove clinging cutting chips, sludge and etc., please confirm there are no contaminants when a workpiece is set. If operating with dirt adhering to the clamping part, it will lead to a workpiece fall due to insufficient clamping force, defective operation and air leakage, etc.

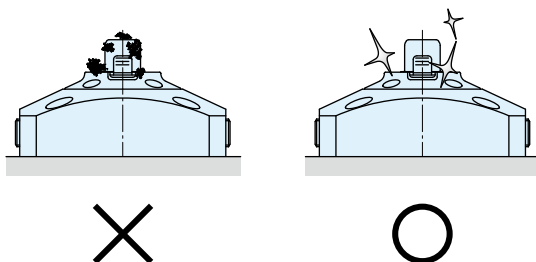

Even with general cleaning on exterior of hole clamp, there may be contaminants within internal parts of the component. If necessary, please call us for repair. If repair or modifications are carried out by anyone other than Kosmek, or without our approval or confirmation, it will void warranty.

- 3) Clamping force will be decreased by friction of a gripper surface due to repeated operation. Replacement period differs depending on operating pressure, workpiece material and shape of hole. When you find friction on gripper surface, the gripper needs to be replaced. Please contact us for overhaul.

Material of Clamping Hole	Gripper Replacement Frequency Guide
A2017 Aluminum	Locking operation 1 million cycles
SCM435 Thermal Refined Steel	Locking operation 500,000 cycles

※ It varies depending on the operating conditions. Please request an overhaul after confirming its suitability for the actual machine.

- 4) Please contact us for overhaul and repairs.  
Built-in spring is very strong and can be dangerous.

## ⓘ Cautions

### ● Notes on Handling

- 1) It should be operated by qualified personnel.
  - The hydraulic machine and air compressor should be operated and maintained by qualified personnel.
- 2) Do not operate or remove the product unless the safety protocols are ensured.
  - ① The machine and equipment can only be inspected or prepared when it is confirmed that the safety devices are in place.
  - ② Before the product is removed, make sure that the above-mentioned safety devices are in place. Shut off the pressure and power source, and make sure no pressure exists in the air and hydraulic circuits.
  - ③ After stopping the product, do not remove until the temperature drops.
  - ④ Make sure there is no abnormality in the bolts and respective parts before restarting the machine or equipment.
- 3) Do not touch a clamp (cylinder) while it is working. Otherwise, your hands may be injured due to clinching.

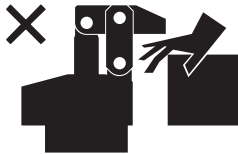

- 4) Do not disassemble or modify.
  - If the equipment is taken apart or modified, the warranty will be voided even within the warranty period.

### ● Maintenance and Inspection

- 1) Removal of the Machine and Shut-off of Pressure Source
  - Before the machine is removed, make sure that safety devices and preventive devices are in place. Shut off the pressure and power source, and make sure no pressure exists in the air and hydraulic circuits.
  - Make sure there is no abnormality in the bolts and respective parts before restarting.
- 2) Regularly clean the area around the piston rod and plunger.
  - If it is used when the surface is contaminated with dirt, it may lead to packing seal damage, malfunctioning and fluid leakage.

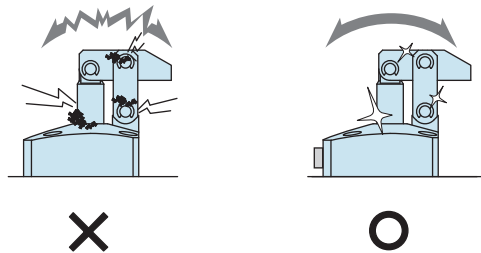

- 3) Please clean out the reference surfaces on a regular basis (taper reference surface and seating surface) of the locating products. (VS/VT/VFL/VFM/VFJ/VFK/WVS/VWM/VWK/VX/VXE/VXF)
  - The locating products, except VX/VXE/VXF model, can remove contaminants with cleaning functions. However, hardened cutting chips, adhesive coolant and others may not be removed. Make sure there are no contaminants before installing a workpiece/pallet.
  - Continuous use with contaminant on components will lead to locating accuracy failure, malfunction and fluid leakage.

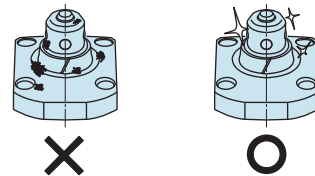

- 4) If disconnecting by couplers, air bleeding should be carried out on a regular basis to avoid air mixed in the circuit.
- 5) Regularly tighten nut, bolt, pin, cylinder, pipe line and others to ensure proper use.
- 6) Make sure the hydraulic fluid has not deteriorated.
- 7) Make sure there is a smooth action without an irregular noise.
  - Especially when it is restarted after left unused for a long period, make sure it can be operated correctly.
- 8) The products should be stored in the cool and dark place without direct sunshine or moisture.
- 9) Please contact us for overhaul and repair.

## ● Warranty

### 1) Warranty Period

- The product warranty period is 18 months from shipment from our factory or 12 months from initial use, whichever is earlier.

### 2) Warranty Scope

- If the product is damaged or malfunctions during the warranty period due to faulty design, materials or workmanship, we will replace or repair the defective part at our expense.

Defects or failures caused by the following are not covered.

- ① If the stipulated maintenance and inspection are not carried out.
- ② If the product is used while it is not suitable for use based on the operator's judgment, resulting in defect.
- ③ If it is used or operated in an inappropriate way by the operator. (Including damage caused by the misconduct of the third party.)
- ④ If the defect is caused by reasons other than our responsibility.
- ⑤ If repair or modifications are carried out by anyone other than Kosmek, or without our approval and confirmation, it will void warranty.
- ⑥ Other caused by natural disasters or calamities not attributable to our company.
- ⑦ Parts or replacement expenses due to parts consumption and deterioration. (Such as rubber, plastic, seal material and some electric components.)

Damages excluding from direct result of a product defect shall be excluded from the warranty.

High-Power  
Series

Pneumatic Series

Hydraulic Series

Valve / Coupler  
Hydraulic Unit

Manual Operation  
Accessories

Cautions / Others

#### Cautions

Installation Notes  
(For Hydraulic Series)

Hydraulic Fluid List

Notes on Hydraulic Cylinder  
Speed Control Circuit

Notes on Handling

Maintenance/  
Inspection

Warranty

Company Profile

Company Profile

Our Products

History

Index

Search by  
Alphabetical Order

Sales Offices

# Sales Offices

## Sales Offices across the World

Japan	KOSMEK LTD. HEAD OFFICE	<b>TEL. +81-78-991-5162</b> FAX. +81-78-991-8787 1-5, 2-chome, Murotani, Nishi-ku, Kobe-city, Hyogo, Japan 651-2241
USA	KOSMEK (USA) LTD. Overseas Subsidiary	<b>TEL. +1-630-620-7650</b> FAX. +1-630-620-9015 650 Springer Drive, Lombard, IL 60148 USA
	KOSMEK USA ATLANTA BRANCH OFFICE	<b>TEL. +1-630-620-7650</b> 303 Perimeter Center North, Suite 300, Atlanta, GA 30346 USA
Mexico	KOSMEK USA MEXICO BRANCH OFFICE	<b>TEL. +52-442-851-1377</b> Av. Loma Pinal de Amoles 320-piso PH oficina 504 interior 13, Vista Dorada, 76060 Santiago de Querétaro, Qro. Mexico
Europe	KOSMEK EUROPE GmbH Overseas Subsidiary	<b>TEL. +43-463-287587</b> FAX. +43-463-287587-20 Schleppeplatz 2 9020 Klagenfurt am Wörthersee Austria
China	KOSMEK (CHINA) LTD. Overseas Subsidiary	<b>TEL.+86-21-54253000</b> FAX. +86-21-54253709 Room601, RIVERSIDE PYRAMID No.55, Lane21, Pusan Rd, Pudong Shanghai China
	KOSMEK (CHINA) LTD. Dongguan Office Overseas Subsidiary (Sales Office)	<b>TEL.+86-769-85300880</b> Room 603, Xinchuang Power Building (No. 122-1 West Houjie Avenue), Houjie Town, Dongguan City, Guangdong Province, China
	KOSMEK (CHINA) LTD. Wuhan Office Overseas Subsidiary (Sales Office)	<b>TEL.+86-15802172393</b> Room 309, Chuanggu Technology Building, 266 Taizihu Rd, Zhuankou Subdistrict, Caidian District, Wuhan 430056, Hubei Province, China
India	KOSMEK LTD. - INDIA Branch	<b>TEL. +91-9880561695</b> 4A/Old No:649, Ground Floor, 4th D cross, MM Layout, Kavalbyrasandra, RT Nagar, Bangalore -560032 India
Thailand	KOSMEK Thailand Representative Office Representative Office	<b>TEL. +66(0)2-059-2010</b> No.139, Blue Chips Building, 4th Floor, Room No.422, Soi Sukhumvit 63 (Thong Lor 10), Sukhumvit Road, Khlong Tan Nuea, Wattana, Bangkok 10110, Thailand
Taiwan	FULL LIFE TRADING CO., LTD. Distributor	<b>TEL. +886-2-82261860</b> FAX. +886-2-82261890 16F-4, No.2, Jian Ba Rd., Zhonghe District, New Taipei City Taiwan 23511
Philippines	G.E.T. Inc, Phil. Distributor	<b>TEL.+63-2-310-7286</b> FAX. +63-2-310-7286 Victoria Wave Special Economic Zone Mt. Apo Building, Brgy. 186, North Caloocan City, Metro Manila, Philippines 1427
Indonesia	PT. Yamata Machinery Sales Distributor	<b>TEL. +62-21-29628607</b> FAX. +62-21-29628608 Delta Commercial Park I, Jl. Kenari Raya B-08, Desa Jayamukti Kec. Cikarang Pusat Kab. Bekasi 17530 Indonesia

## Sales Offices in Japan

Head Office Osaka Sales Office Overseas Sales	<b>TEL. 078-991-5162</b> FAX. 078-991-8787 1-5, 2-chome, Murotani, Nishi-ku, Kobe-city, Hyogo, 651-2241, Japan
Tokyo Sales Office	<b>TEL. 048-652-8839</b> FAX. 048-652-8828 81, 4-chome, Onari-cho, Kita-ku, Saitama City, Saitama, 331-0815, Japan
Nagoya Sales Office	<b>TEL. 0566-74-8778</b> FAX. 0566-74-8808 10-1, 2-chome, Misono-cho, Anjo City, Aichi, 446-0076, Japan
Fukuoka Sales Office	<b>TEL. 092-433-0424</b> FAX. 092-433-0426 8-10-101, 1-chome, Kamimuta, Hakata-ku, Fukuoka City, Fukuoka, 812-0006, Japan

# Global Network

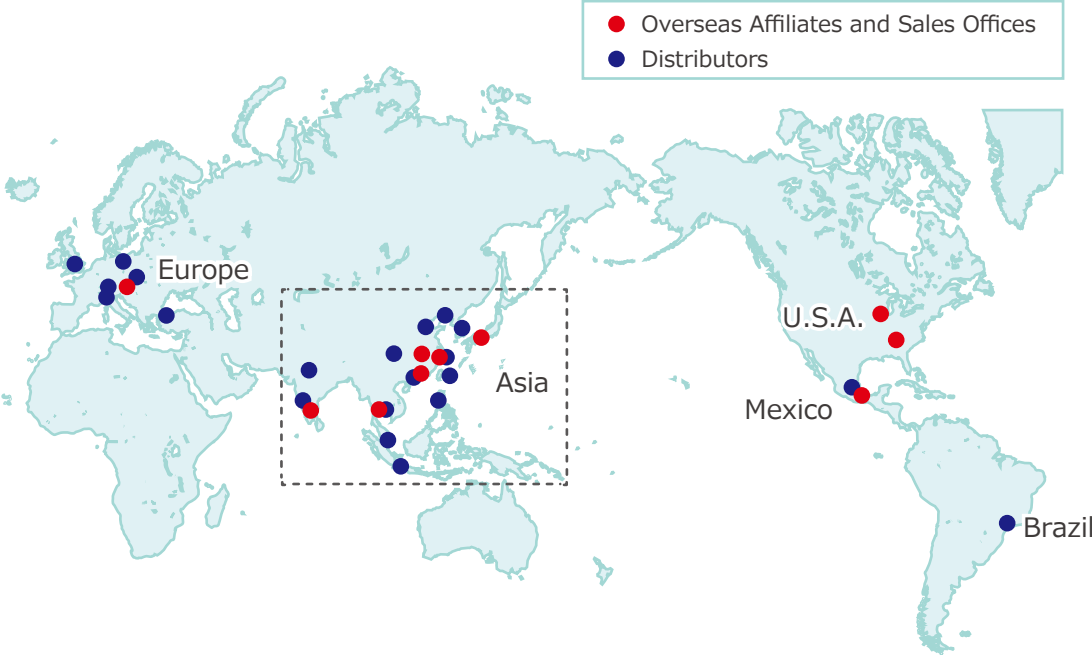

Asia Detailed Map



● FOR FURTHER INFORMATION ON UNLISTED SPECIFICATIONS AND SIZES, PLEASE CALL US.  
● SPECIFICATIONS IN THIS CATALOG ARE SUBJECT TO CHANGE WITHOUT NOTICE.

