

~Locate/Clamp~

Pallet Clamp

“How to locate and clamp the pallet w/o accuracy tests?”



Instant and Accurate Pallet Clamp

(Spring-Lock, Hydraulic-Release)

- High Locating Accuracy (3 μ m)
- Strong Clamping Force (Up to 40kN per clamp)
- Air Blow and Seating Confirmation
- Spring-Lock Mechanism

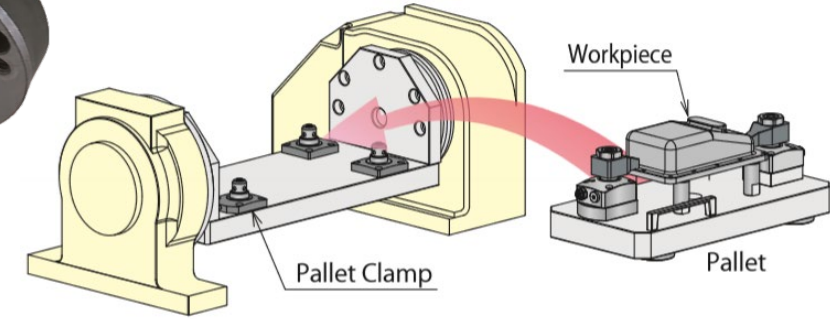
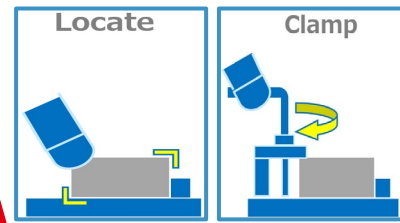

Manual Pallet Change

Pallet alignment is **Instant**

- High Accuracy Locating
- Clamping Function
- Air-Blow and Seat Check

Locating Repeatability : 3 μ m
No need to inspect the fixture alignment inside the machine.

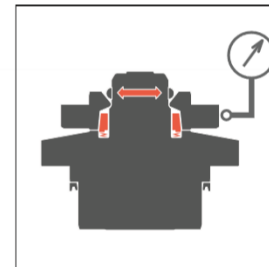

Clamping force is ranged from 2.5kN to 40kN.
Possible to select clamping force depending on purpose.

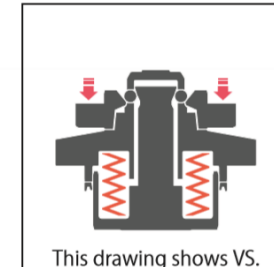

This drawing shows VS.

Contaminants are removed by air blow.
Seating surface is provided with the air hole, seat check is possible by using a gap sensor.

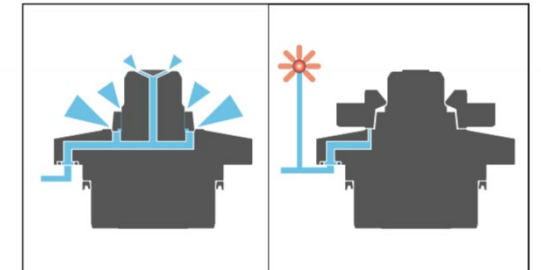

KOSMEK Exclusive Locating Function : Accuracy Guarantee with Movable Taper Sleeve

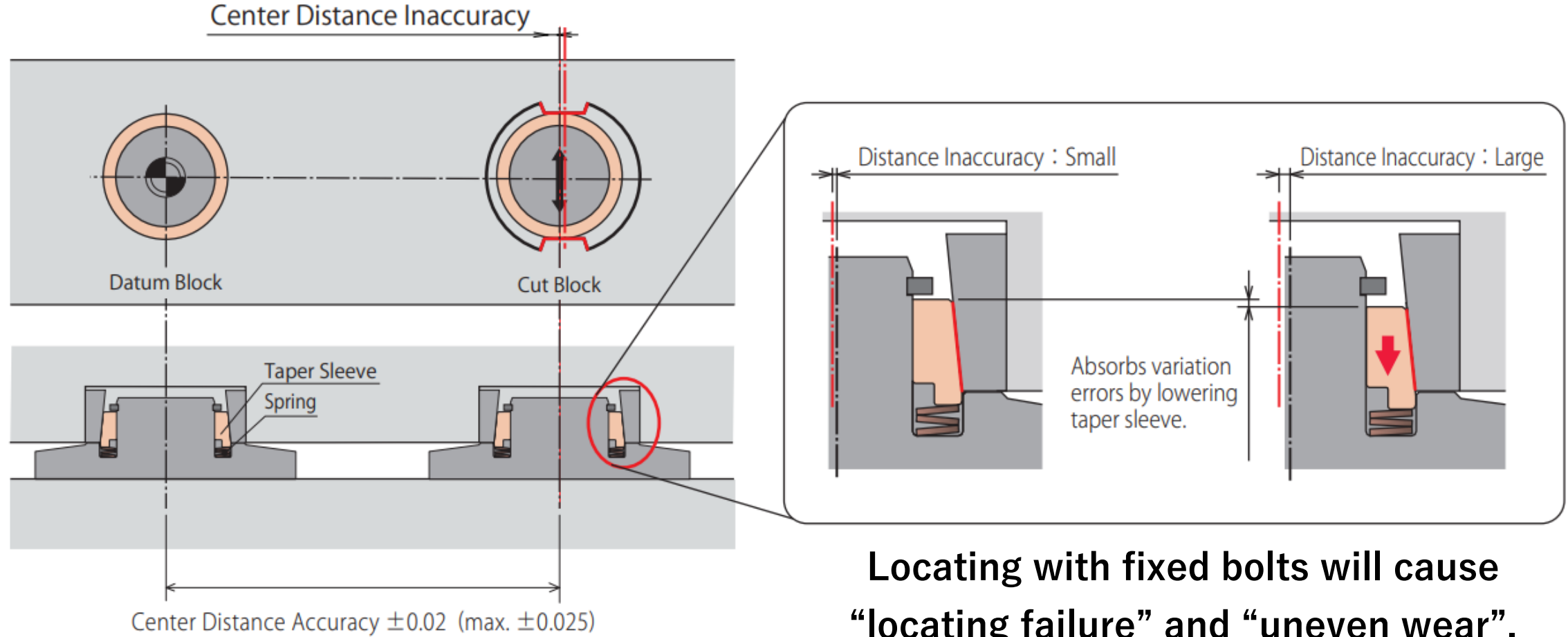

**Locating with fixed bolts will cause
“locating failure” and “uneven wear”.**

KOSMEK Exclusive Locating Function : High Rigidity and Locating Repeatability with Dual Contact

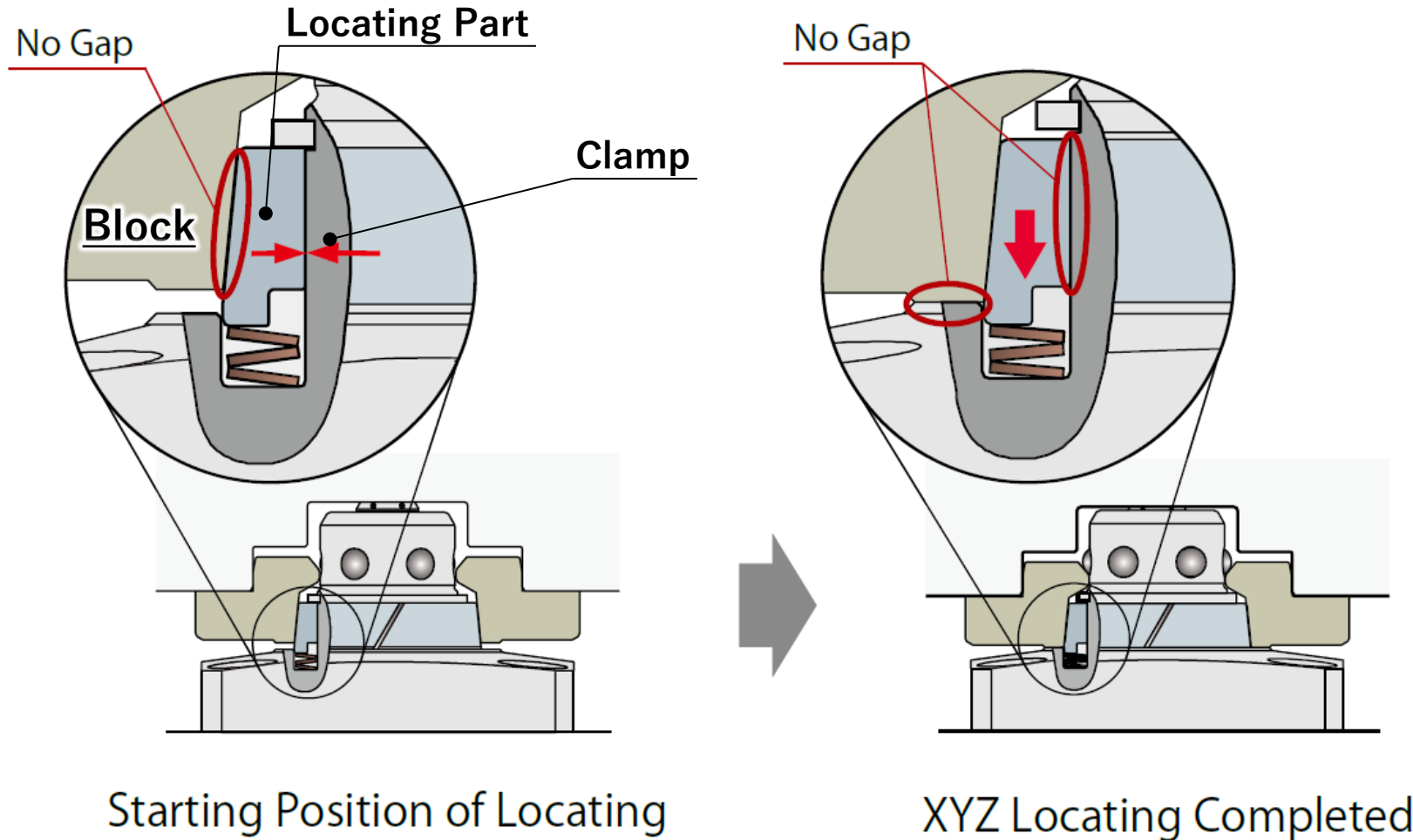

Advantage 3: Durability / Environmental Resistance

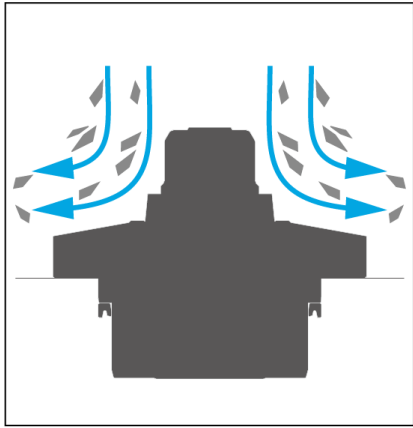

**Easy-to-Clean
Body Shape**

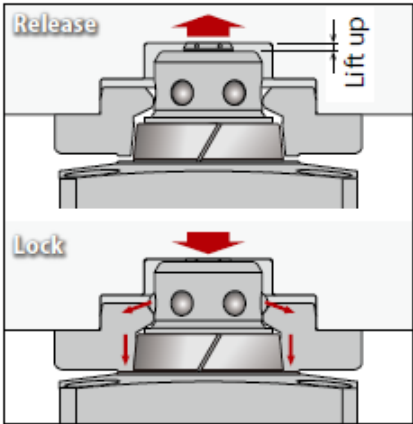

**Lift-up
Function**

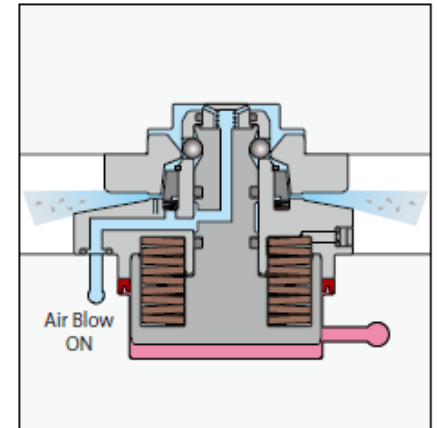
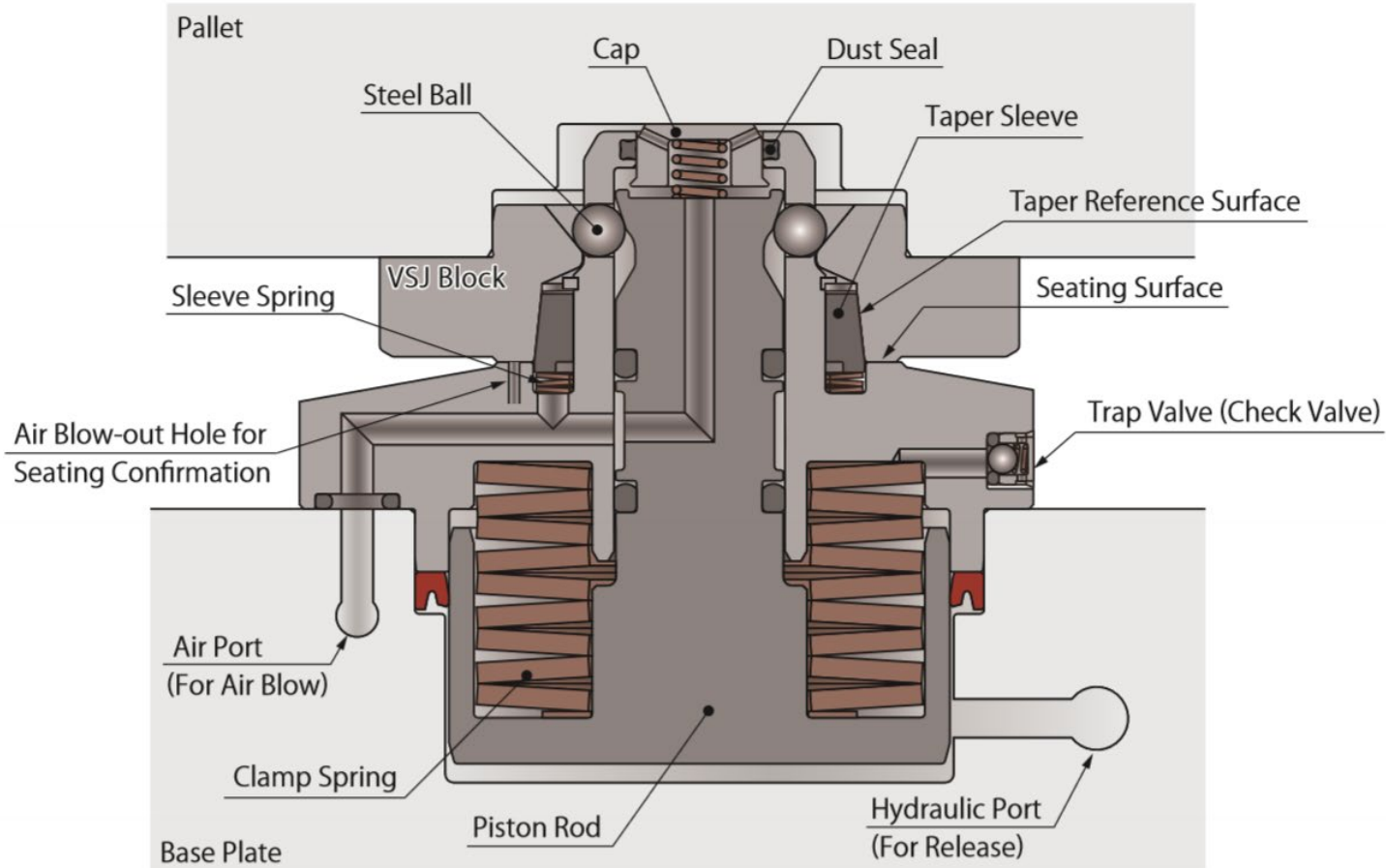

**Air Blow
Function**

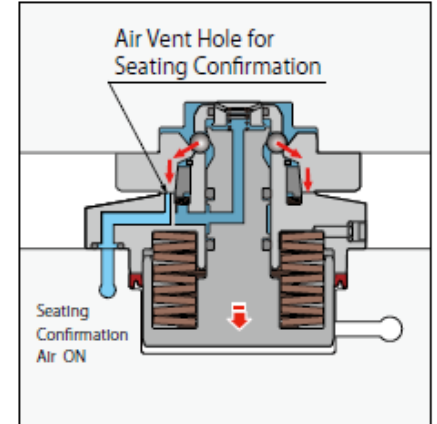

**Seat Check
Function**