

New

Hole Gripper



Model WKK

Hole Gripper

Model WKK



Transferring Workpieces with I.D. Gripping

Hole Gripper allows for 5 face accessibility. Light Weight, Compact and Mechanical Lock

- For transferring workpieces to and from various machining processes

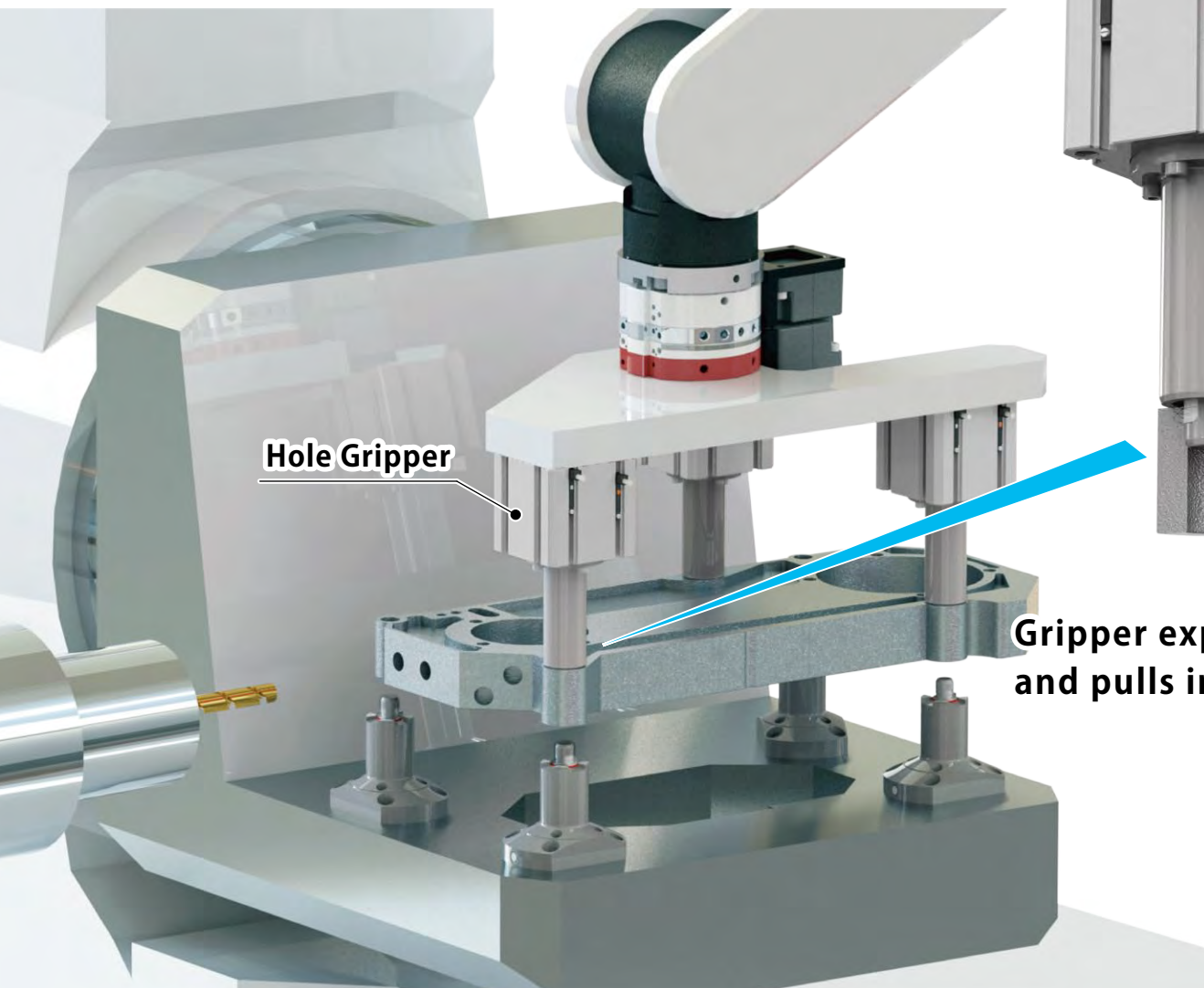

Gripper expands and pulls in.

Action Description

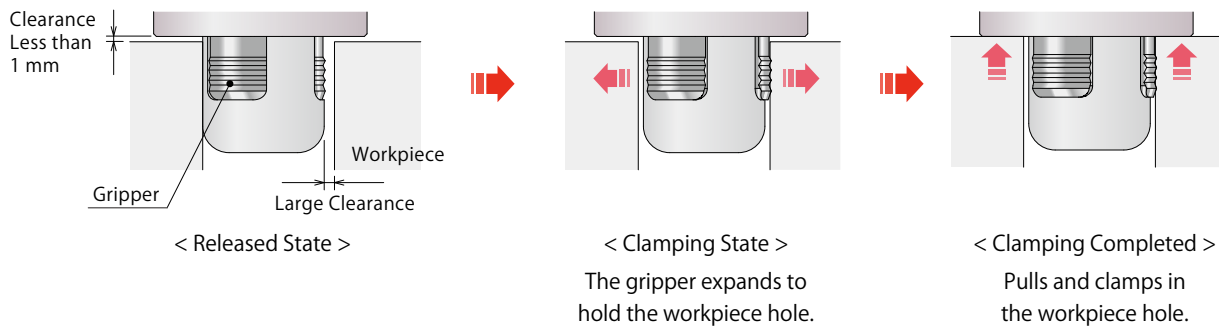

Advantages

• Space Saving for Transfer Hand • Stocker

- Less interference compared to a hand that holds an outer surface of a workpiece:

(1) Teaching will be easier.
 (2) Transfer hands can be compact.

- Removing exterior tooling clearance enables space saving for workpiece stockers.

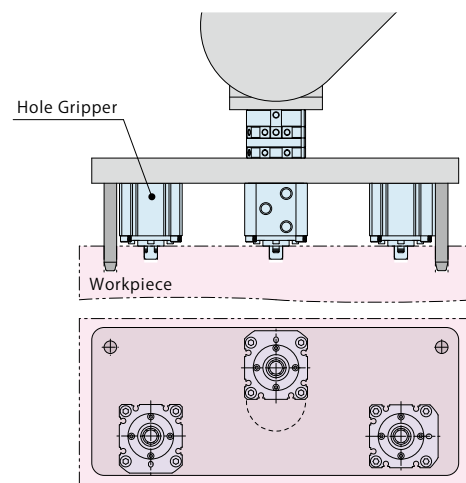

- Workpiece holding stroke is short to allow for quicker gripping cycles. Eliminating interference enables robots to operate in a smaller footprint, leading to overall reduction in transfer time.

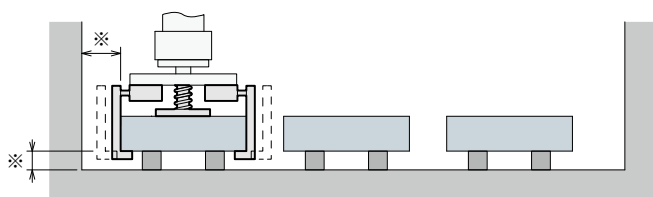

※ Operating range of the transfer hand

Traditional Exterior Transfer Stocking Method

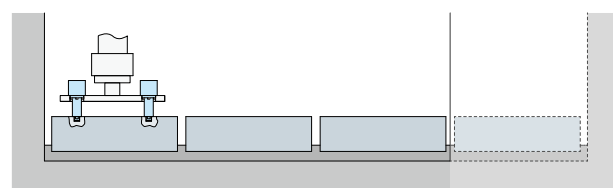

Kosmek Hole Gripper Stocking Method

• Using Transfer Hand as Fixture

- Hole gripper needs one face to hold the workpiece so 5 faces are accessible with no tooling interference. A robot can hold a workpiece and continue to the next processes by using a transfer hand as a fixture. Other processes can include deburring, washing and etc.

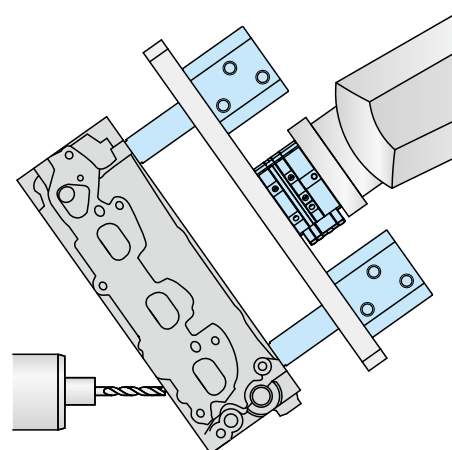

● Features

● Protective Cap for Stable Automation

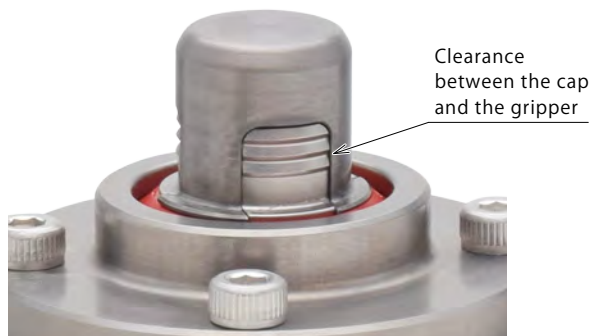

- Minimal clearance between the cap and the gripper prevents cutting chips from entering inside the hole gripper.

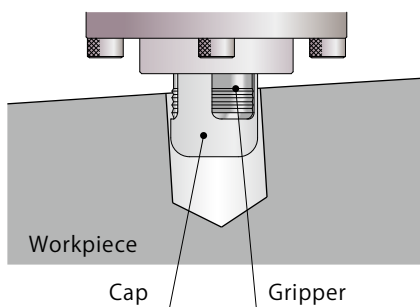

- The cap prevents the gripper from frictional wear when inserted to a workpiece hole. Loading and unloading becomes smoother with the cap preventing the gripper from touching the workpiece.

● Air Blow Function Ensures Longevity Even in Machining Environments

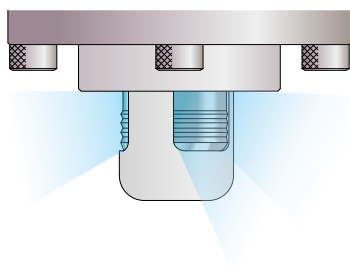

- Even with a little air flow, by air purging from the inside, it prevents coolant from entering inside the hole gripper.

● Action Confirmation Available



- Lock and release actions can be confirmed by an auto switch (sold separately).
 - ※ An auto switch is not included in WKK. Prepare it by referring to P.6.

Secured with Self-Locking Function

- A built-in spring is provided in the lock side. This prevents a workpiece from falling even when air supply is lost due to blackout or cutoff of air hose.

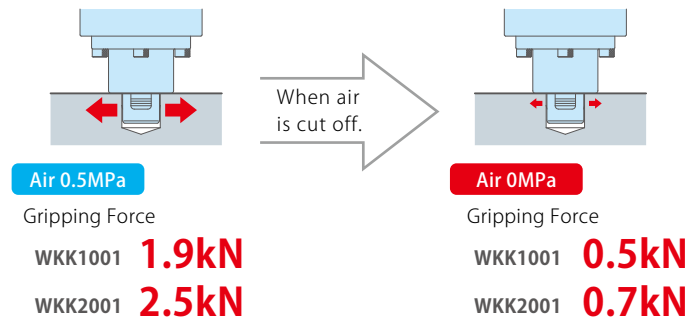

Wide Range of Hole Diameters to Suit a Variety of Workpieces

- In order to suit different hole diameters and tolerances, hole diameters can be specified in 0.5mm increments.

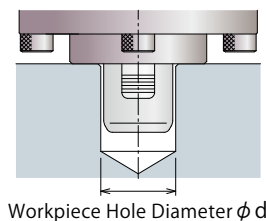

Model No.	Workpiece Hole Diameter (mm)															
	6	6.5	7	7.5	8	8.5	9	9.5	10	10.5	11	11.5	12	12.5	13	
WKK1001	Selectable Range															
WKK2001							Selectable Range									

※ Workpiece hole diameter $\phi 6$ cannot be selected for a tapered workpiece hole.

Wide Range of Seating Surface Heights

- Level the height in 10mm increments according to the workpiece seating surface. This is effective to prevent interferences with workpieces.

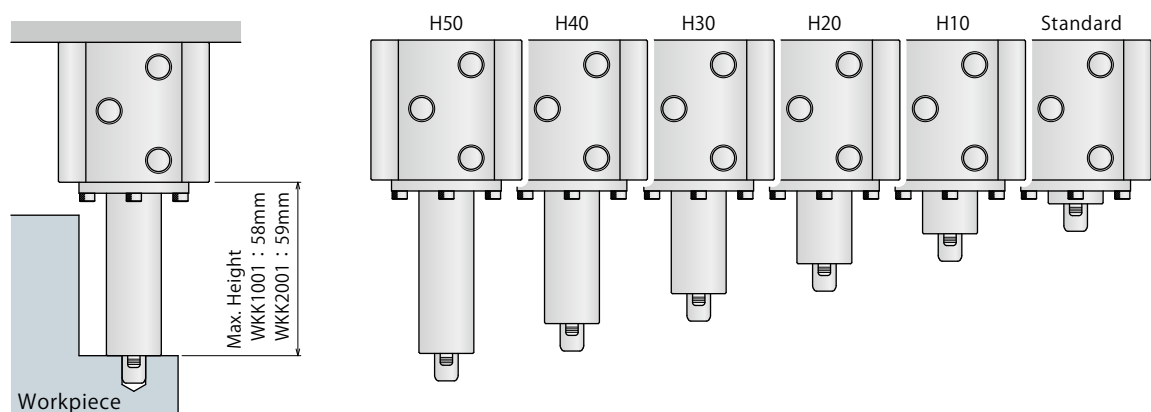

- Machining process and washing process can be used with the Hole Gripper. The available seating height options allows auto switches and air piping to be protected from coolant and cutting fluid by installing the back plate and adjusting the seating height accordingly.

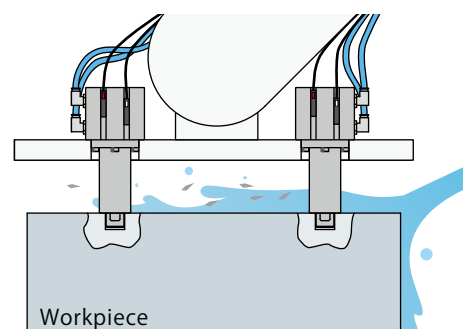

Action Description ※ This is a simplified drawing. The actual part components may be different.

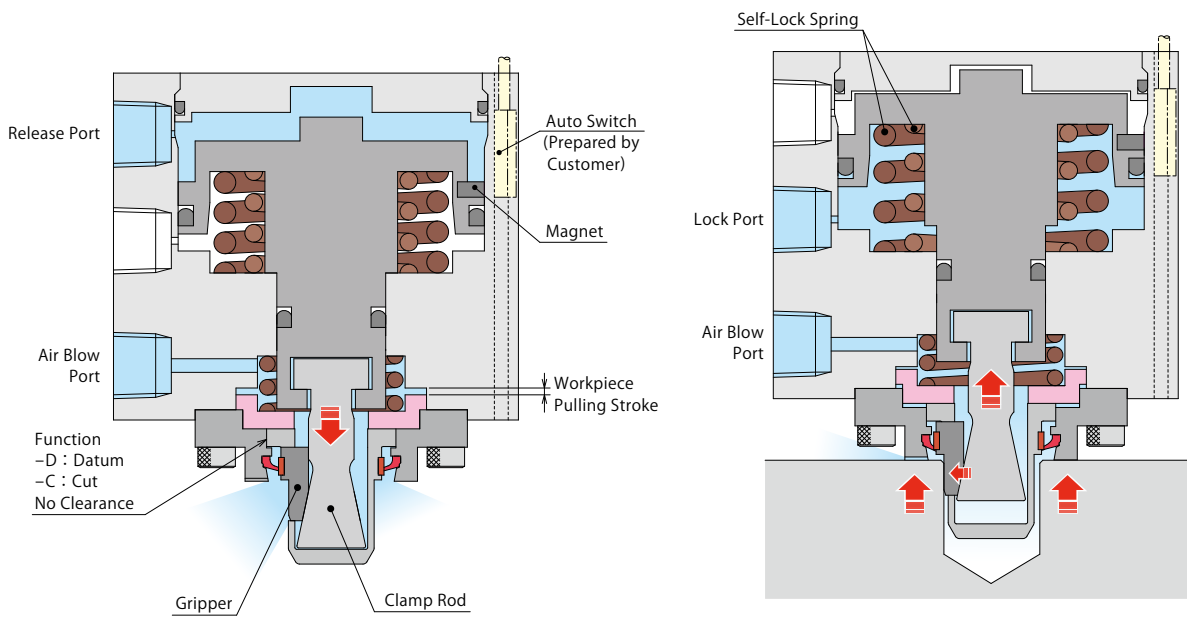

Release Action Description

- ① Air is supplied to the release port.
- ↓
- ② The clamp rod is moved forward by the air pressure, and the gripper will be retracted.
- ※ Continuously supply air to the air blow port in order to prevent contamination.

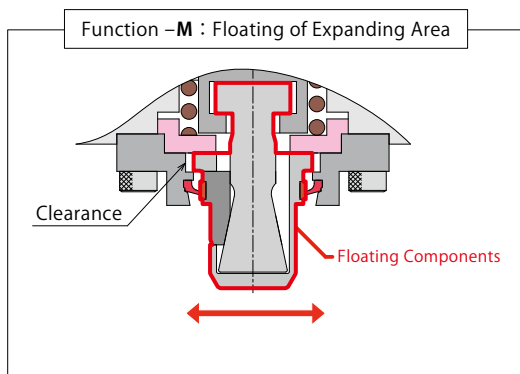

Lock Action Description

- ① Release air to the release port and supply air to the lock port.
- ↓
- ② The self-locking spring force and air pressure powerfully pulls in the clamp rod. The gripper will be expanded.
- ↓
- ③ After the gripper holds a workpiece, the pulling force pulls in the workpiece onto the seating surface. (Clamping Force = Pulling Force toward Seating Surface)

Auto Switch

Locking position and releasing position can be detected by an auto switch (prepared by customer).

Installation Sample 1



Installation Sample 2



Note :

- Depending on difference of workpiece hole diameter, the detection range of an auto switch can be insufficient.
If using an auto switch (JEP), workpiece hole diameter difference should be within $\pm 0.3\text{mm}$.

【Applicable Auto Switch / High-Accuracy Sensor for Air Cylinder】

Switch Type	Model No.	Output Method	Wiring Method	Cable Length	Shape	Protection Grade
Auto Switch	JEP0000-B2	Non-Contact : NPN Output	3-Wire	1m	Straight 	IP67
	JEP0000-B2L			3m		
	JEP0000-B3C			1m	L Shaped 	
	JEP0000-B3CL			3m		
	JEP0000-B3B	Non-Contact	2-Wire	1m	L Shaped 	
	JEP0000-B3BL			3m		
High-Accuracy Sensor for Air Cylinder ※1	JES0000-02GN	Non-Contact : NPN Output N-Pole Sensor※2	3-Wire	1m	Straight 	IP67
	JES0000-02GS	Non-Contact : NPN Output S-Pole Sensor※2				
	JES0000-02GPN	Non-Contact : PNP Output N-Pole Sensor※2				
	JES0000-02GPS	Non-Contact : PNP Output S-Pole Sensor※2				
	JES0000-02LGN	Non-Contact : NPN Output N-Pole Sensor※2			L Shaped 	
	JES0000-02LGS	Non-Contact : NPN Output S-Pole Sensor※2				
	JES0000-02LGPN	Non-Contact : PNP Output N-Pole Sensor※2				
	JES0000-02LGPS	Non-Contact : PNP Output S-Pole Sensor※2				

Notes :

- For further information, refer to the product catalogs of Auto Switch (JEP) and High-Accuracy Sensor for Air Cylinder (JES) on our website. When using an auto switch not made by Kosmek, check specifications of each manufacturer.
 - Auto Switch / High-Accuracy Sensor for Air Cylinder may be stuck out of the hole gripper depending on the installation position and direction.
- ※1. The detection range of High-Accuracy Sensor for Air Cylinder (JES) is different from Auto Switch (JEP), and even small stroke can be securely detected by JES. Refer to "Performance Curve" on the JES catalog for further information.
- ※2. When detecting both lock and release actions with High-Accuracy Sensor for Air Cylinder (JES), both N-pole sensor and S-pole sensor are required.

● Model No. Indication (Workpiece Hole Shape : Straight)

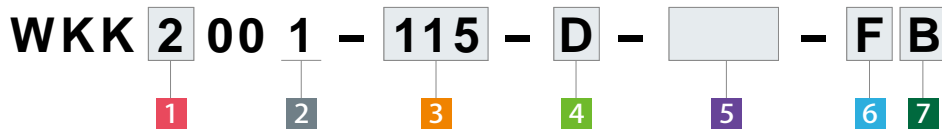

1 Body Size

- 1 : Select from workpiece hole diameters between $\phi 6$ and $\phi 9$
- 2 : Select from workpiece hole diameters between $\phi 9$ and $\phi 13$

2 Design No.

- 1 : Revision Number

3 Workpiece Hole Diameter (Workpiece Hole Code)

Workpiece Hole Code : Workpiece Hole Diameter $\phi d^{+0.7}_{-0.3}$

Workpiece Hole Code	060	065	070	075	080	085	090	095	100	105	110	115	120	125	130	
Hole Diameter $\phi d^{+0.7}_{-0.3}$ (mm)	6	6.5	7	7.5	8	8.5	9	9.5	10	10.5	11	11.5	12	12.5	13	
WKK1001	▲	▲	Allowable Range													
WKK2001								Allowable Range								

- ※ Indicate the workpiece hole diameter ϕd within the allowable range in 0.5mm increments.
- ※ For the hole diameters marked with ▲, the maximum operating pressure is 0.5MPa.
- ※ When using with Auto Switch (JEP), workpiece hole diameter variance should be within $\pm 0.3\text{mm}$.

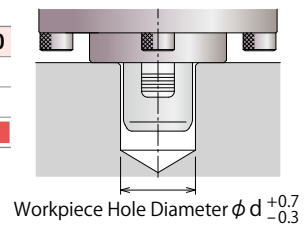

4 Functions

- D** : Datum (For Reference Locating)
- C** : Cut (For One Direction Locating)
- M** : Floating of Expanding Area (No Locating Function)

※ When using it with expansion locating pin (model VWH, VWM, VWK, VRA, VRC, VX, etc.) please select Function **M**.

Workpiece Hole Code	060 ~ 085	090 ~ 130
Function D	Not Available	Available Gripper Qty. : 3
Function C	Available Gripper Qty. : 2	Available Gripper Qty. : 2
Function M	Available Gripper Qty. : 2	Available Gripper Qty. : 3

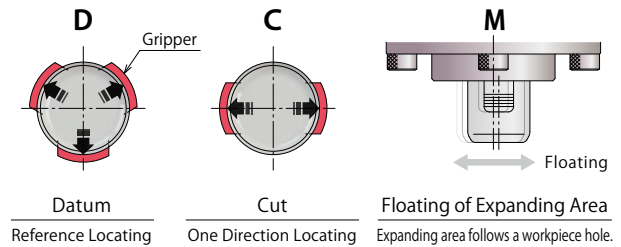

※ When roughly locating a workpiece with workpiece hole code 060 ~ 085, refer to "Hole Gripper Installation" on P.25.

5 Seating Height Dimension

Blank : Standard Height

H **Seating Height** : Specified Seating Height (In 10mm increments)
(mm)

Model No.	Symbol	Standard	Specified				
		Blank	H10	H20	H30	H40	H50
WKK1001	AA	55	65	75	85	95	105
	AB	8	18	28	38	48	58
WKK2001	AA	60	70	80	90	100	110
	AB	9	19	29	39	49	59

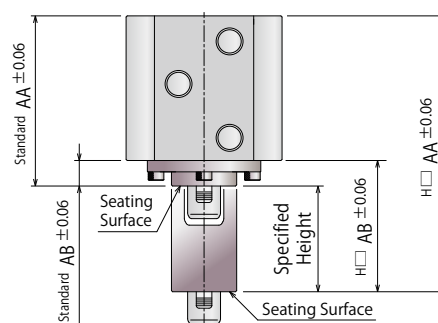

6 Shape of Gripper (Workpiece Hole)

F : No Serration (Workpiece Hole Shape : Straight)

S : With Serration (Workpiece Hole Shape : Straight)

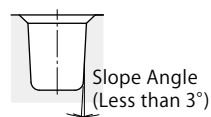
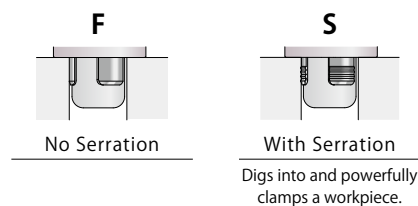

Taper Hole

Refer to P.9 ~ P.10 for the taper workpiece hole.

※ Contact us when ordering the taper hole model.

7 Shape of Cap End

Blank : Standard (Low Head Model)

B : Cone Point Model

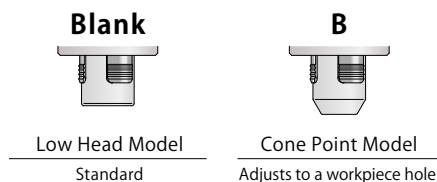

※ When inserting the cap adjusting to a workpiece hole, it should be within the floating range, or a workpiece should be light and not fixed.

● Model No. Indication (Workpiece Hole Shape : Tapered)

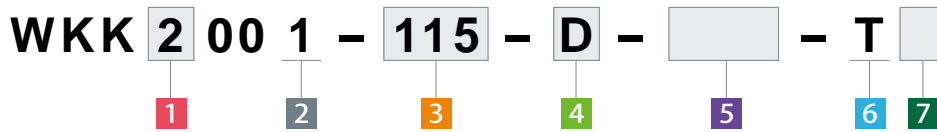

1 Body Size

- 1 : Select from workpiece hole diameters between $\phi 6.5$ and $\phi 9$
- 2 : Select from workpiece hole diameters between $\phi 9$ and $\phi 13$

2 Design No.

- 1 : Revision Number

3 Workpiece Hole Diameter (Workpiece Hole Code)

Workpiece Hole Code : Workpiece Hole Mouth Diameter ϕd

- ※ Workpiece hole mouth diameter ϕd should be specified in 0.5mm increments from the allowable range in the following table.
- ※ The allowable tolerance of the hole mouth diameter ϕd differs depending on the slope angle. Refer to the table below.

Workpiece Hole Code	060	065	070	075	080	085	090	095	100	105	110	115	120	125	130
Hole Mouth Diam. ϕd (mm)	-	6.5	7	7.5	8	8.5	9	9.5	10	10.5	11	11.5	12	12.5	13
WKK1001		▲	▲	Allowable Range											
WKK2001								Allowable Range							

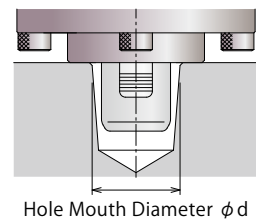

- ※ For the hole diameters marked with ▲, the maximum operating pressure is 0.5MPa.
- ※ The workpiece hole diameter : **060** cannot be selected for the taper workpiece hole model.
- ※ When using with Auto Switch (JEP), workpiece hole diameter variance should be within $\pm 0.3\text{mm}$.

Workpiece Hole Slope Angle and Allowable Tolerance of Hole Mouth Diameter

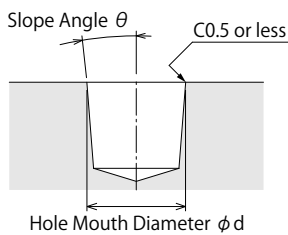

Model No.	Workpiece Hole Code	Slope Angle θ	Allowable Tolerance of Hole Mouth Diam.
WKK1001	065 ~ 085	$1 \leq \theta \leq 2.5$	$\phi d \pm 0.3$
		$2.5 < \theta \leq 3$	$\phi d \begin{smallmatrix} +0.3 \\ -0.15 \end{smallmatrix}$
	090	$1 \leq \theta \leq 2$	$\phi d \pm 0.3$
		$2 < \theta \leq 2.5$	$\phi d \begin{smallmatrix} +0.3 \\ -0.15 \end{smallmatrix}$
WKK2001	090	$2.5 < \theta \leq 3$	$\phi d \begin{smallmatrix} +0.3 \\ 0 \end{smallmatrix}$
		$1 \leq \theta \leq 2$	$\phi d \pm 0.3$
		$2 < \theta \leq 2.5$	$\phi d \begin{smallmatrix} +0.3 \\ -0.15 \end{smallmatrix}$
	095 ~ 130	$2.5 < \theta \leq 3$	$\phi d \begin{smallmatrix} +0.3 \\ 0 \end{smallmatrix}$
		$1 \leq \theta \leq 2.5$	$\phi d \pm 0.3$
		$2.5 < \theta \leq 3$	$\phi d \begin{smallmatrix} +0.3 \\ -0.15 \end{smallmatrix}$

※ Please contact us when the slope angle is less than 1° .

4 Functions

- D** : Datum (For Reference Locating)
C : Cut (For One Direction Locating)
M : Floating of Expanding Area (No Locating Function)

※ When using it with expansion locating pin (model VWH, VWM, VWK, VRA, VRC, VX, etc.) please select Function **M**.

Workpiece Hole Code	065 ~ 085	090 ~ 130
Function D	Not Available	Available Gripper Qty. : 3
Function C	Available Gripper Qty. : 2	Available Gripper Qty. : 2
Function M	Available Gripper Qty. : 2	Available Gripper Qty. : 3

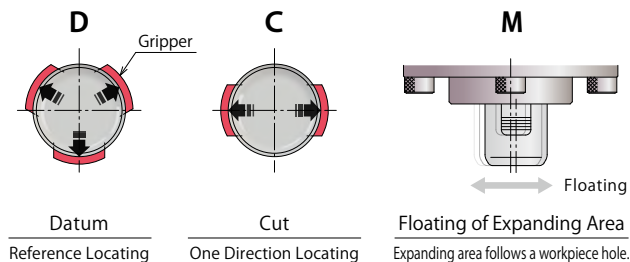

※ When roughly locating a workpiece with workpiece hole code 065 ~ 085, refer to "Hole Gripper Installation" on P.25.

5 Seating Height Dimension

Blank : Standard Height

H **Seating Height** : Specified Seating Height (In 10mm increments)
(mm)

Model No.	Symbol	Standard	Specified				
		Blank	H10	H20	H30	H40	H50
WKK1001	AA	55	65	75	85	95	105
	AB	8	18	28	38	48	58
WKK2001	AA	60	70	80	90	100	110
	AB	9	19	29	39	49	59

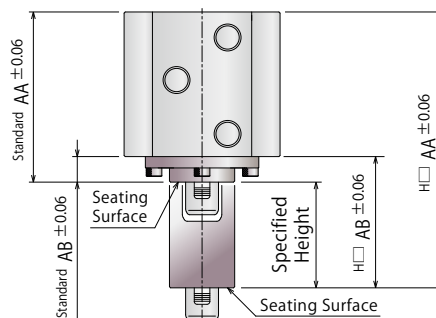

6 Shape of Workpiece Hole (Gripper)

T : Taper Hole (with Serration)

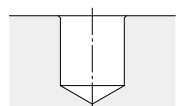
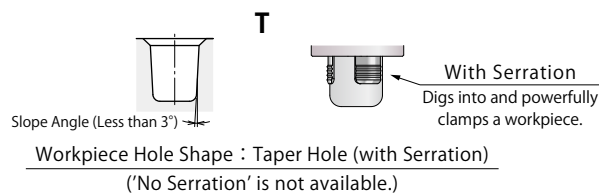

Hole Shape: Straight

Refer to P.7 ~ P.8 for the straight workpiece hole.

7 Shape of Cap End

Blank : Standard (Low Head Model)

(**B** : Cone Point Model)

Blank



Low Head Model
Standard

● Specifications (Workpiece Hole Shape : Straight)

Applicable Model No.

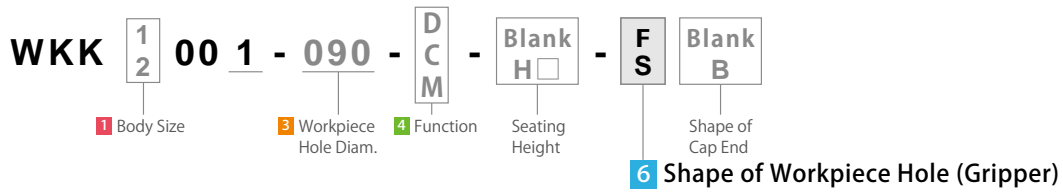

Model No.		WKK1001-□-□-□-□- F □							WKK2001-□-□-□-□- F □							
		WKK1001-□-□-□-□- S □							WKK2001-□-□-□-□- S □							
3 Workpiece Hole Code		060	065	070	075	080	085	090	095	100	105	110	115	120	125	130
Workpiece	Hole Diam. $\phi d \begin{smallmatrix} +0.7 \\ -0.3 \end{smallmatrix}$ mm	6	6.5	7	7.5	8	8.5	9	9.5	10	10.5	11	11.5	12	12.5	13
	Hardness	HB250 or less (In case of 6 S)														
Locating Repeatability ^{※1} mm		0.03 (When combining 4 D and C)														
Allowable Offset (Floating Clearance of Expanding Area) ^{※2} mm		±0.3 (In case of 4 M)							±0.5 (In case of 4 M)							
Workpiece Pulling Stroke mm		1.0														
Cylinder Capacity (Empty Action)	Release cm ³	5.3							6.7							
	Lock cm ³	4.6							5.8							
Max. Operating Pressure MPa		0.5	0.7													
Min. Releasing Pressure MPa		0.25														
Withstanding Pressure MPa		0.75	1.0													
Recommended Air Blow Pressure MPa		0.2 ~ 0.3														
Air Blow Flow Rate (per cylinder) L / min		15 or more														
Operating Temperature °C		0 ~ 70														
Usable Fluid		Dry Air														
Weight		Refer to the external dimensions for the product weight.														

Notes :

※ 1. Locating repeatability under the same condition (no load).

※ 2. The expanding part of option M is an adjusting structure and the clamping operation is done by locating a workpiece hole. The value in the table shows the amount of tolerance value of single hole gripper. Please consider the distance accuracy of each cylinder mounting hole and each workpiece machining hole when using with another location clamp / location cylinder, or when using more than two of these products.

● Gripping Force • Clamping Force Curve

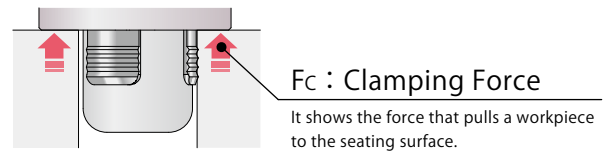
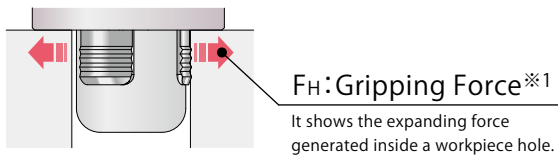

Model No.	3 Workpiece Hole Code	6 S / T : with Serration				6 F : No Serration				
		WKK1001-□-□-□-□-□		WKK1001-□-□-□-□-□		WKK2001-□-□-□-□-□ WKK2001-□-□-□-□-□		WKK1001-□-□-□-□-□		WKK2001-□-□-□-□-□
		060 065	070~090	060 065 070 075~090	090 ~ 130	060 065	070 ~ 090	090 ~ 130		
Gripping Force ^{※1}	N	Air Pressure 0.7 MPa	- - 2500	- - - 2500	3300	- - 2500	3300			
		Air Pressure 0.6 MPa	- - 2200	- - - 2200	2900	- - 2200	2900			
		Air Pressure 0.5 MPa	1900	- 1900	2500	1900	2500			
		Air Pressure 0.4 MPa	1600	- 1600	2200	1600	2200			
		Air Pressure 0.3 MPa	1300	- 1300	1800	1300	1800			
		Air Pressure 0.25 MPa	1200	- 1200	1600	1200	1600			
		Air Pressure 0 MPa (Zero Air Pressure)	480	- 480	700	480	700			
		Calculation Formula ^{※3}	$F_H = 2870P + 480$	- $F_H = 2870P + 480$	$F_H = 3700P + 700$	$F_H = 2870P + 480$	$F_H = 3700P + 700$			
Clamping Force	N	Air Pressure 0.7 MPa	- - 800	- - - 800	1000	- - 210	300			
		Air Pressure 0.6 MPa	- - 700	- - - 700	870	- - 180	260			
		Air Pressure 0.5 MPa	600	- 600	740	160	220			
		Air Pressure 0.4 MPa	490	- 490	610	130	190			
		Air Pressure 0.3 MPa	390	- 390	480	100	150			
		Air Pressure 0.25 MPa	340	- 340	420	88	130			
		Air Pressure 0 MPa (Zero Air Pressure)	80	- 80	90	20	30			
		Calculation Formula ^{※3}	$F_c = 1030P + 80$	- $F_c = 1030P + 80$	$F_c = 1300P + 90$	$F_c = 270P + 20$	$F_c = 390P + 30$			

Gripping Force Curve

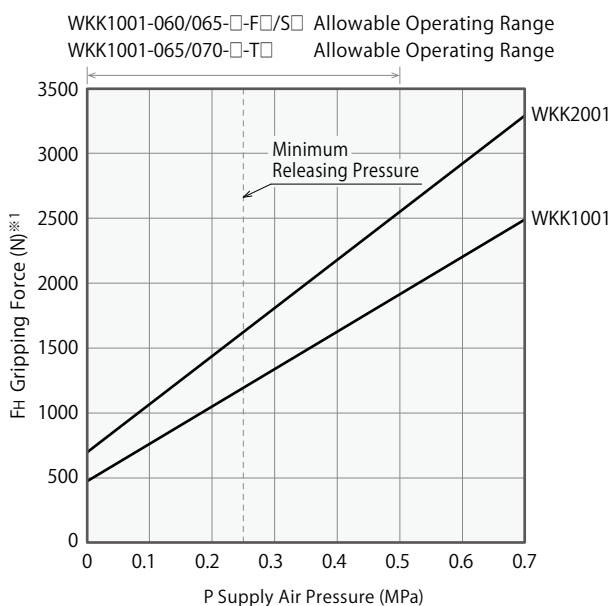

Clamping Force Curve

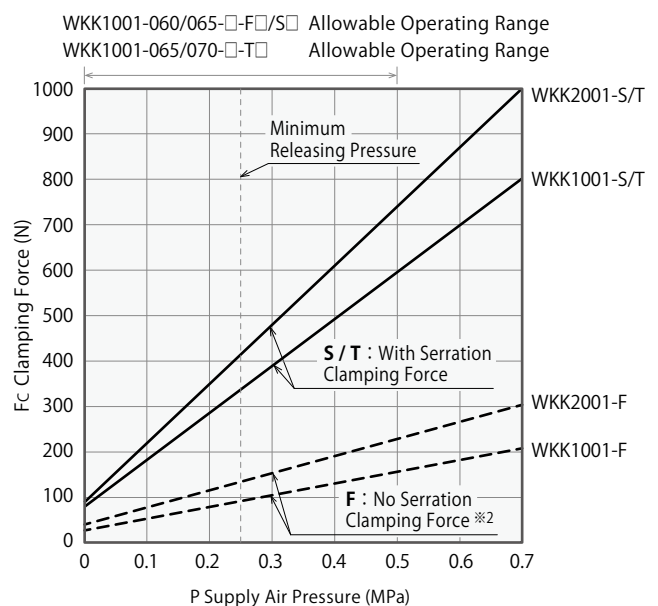

Notes :

1. The table and graph show the relationship among supply air pressure, gripping force and clamping force.

2. Gripping force shows the expanding force acting perpendicular to the hole gripper's center axis.

Clamping force shows the force that pulls a workpiece to the seating surface.

3. Thin wall around the workpiece hole can be deformed by clamping action and the specifications may not be filled.

※1. Gripping force shows the calculated value when the friction coefficient of expanding area is $\mu 0.15$.

※2. Clamping force of F:No Serration shows the calculated value when the friction coefficient of workpiece and gripper is $\mu 0.1$.

※3. F_H:Gripping Force (N), F_c:Clamping Force (N), P:Supply Air Pressure (MPa).

 **MEMO**

External Dimensions

※ The drawing shows the released state of WKK1001-□-C-F.

※ Expanding Area Detail

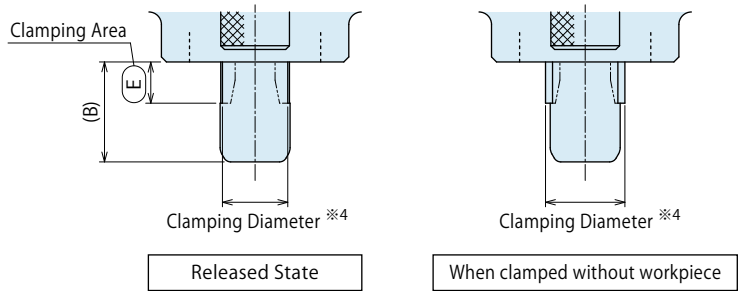
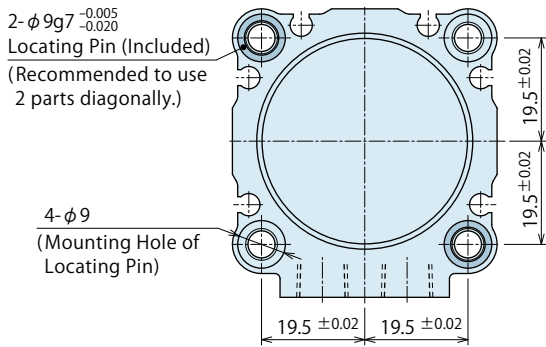

Seating Height: Standard

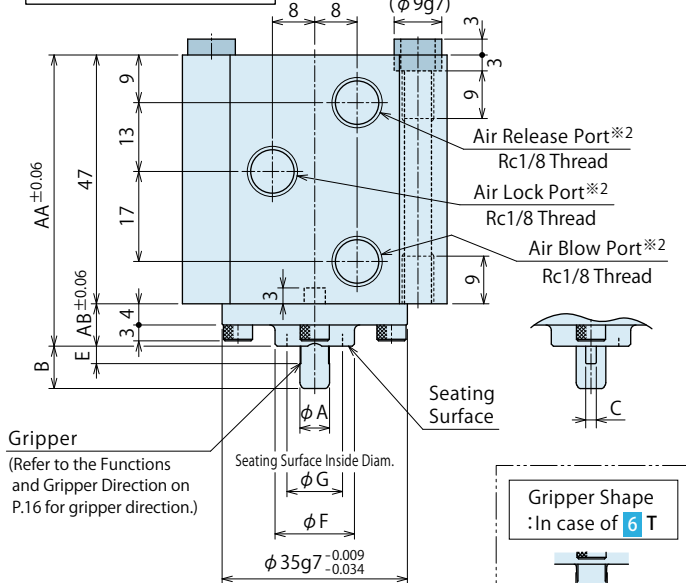

Specified Seating Height: H □ ※3

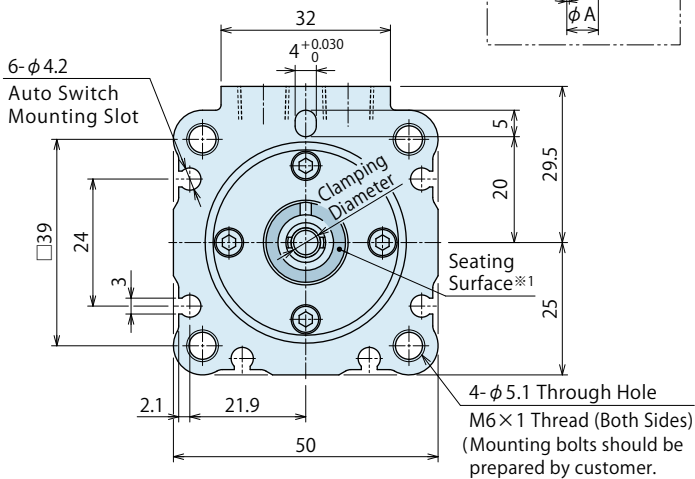
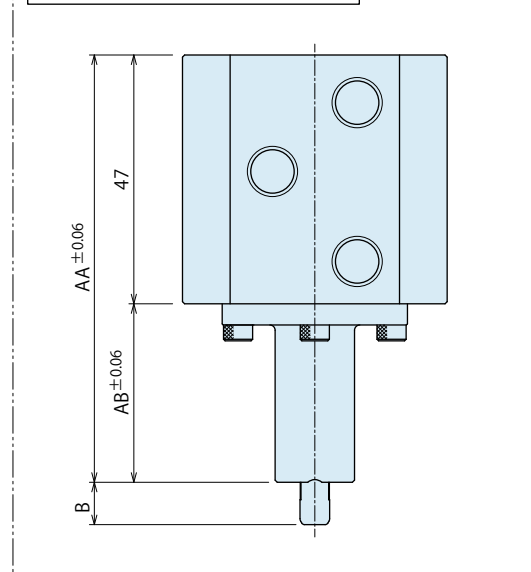

Notes :

1. Mounting bolts are not provided. Please prepare them according to the mounting position. (Refer to "Installation of Hole Gripper" on P.27.)
2. This product locks with air pressure and self-locking spring and releases with air pressure. (When air drops to 0MPa, it will be in the locked state with gripper expansion.)

- ※1. The workpiece must be resting on all seating surfaces when clamping. Otherwise the workpiece can be deformed by the clamping force.
- ※2. The name of each port is marked on the port. (LOCK: Air Lock Port, RELEASE: Air Release Port, BLOW: Air Blow Port) Continuously supply air pressure to the air blow port when in use.

※3. Please refer to the drawing on the left side : Seating Height: Standard for unlisted dimensions.

※4. For -T: Taper Hole model, the first gripper ridge is the reference diameter.

Machining Dimensions of Workpiece (Pallet) Hole

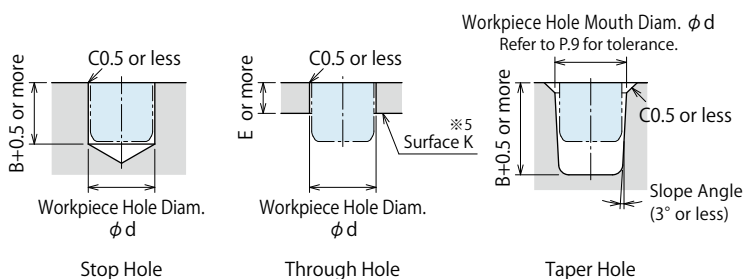

Notes :

1. Thin wall around the workpiece hole can be deformed by clamping action, gripping force and clamping force will not fill the specification. Please make sure to test the clamping function before using and adjust to the appropriate supply of pressure.

※5. When the hole gripper head is sticking above the surface K of the workpiece, please make sure there is no interference with the hole gripper during machining.

Functions and Gripper Direction

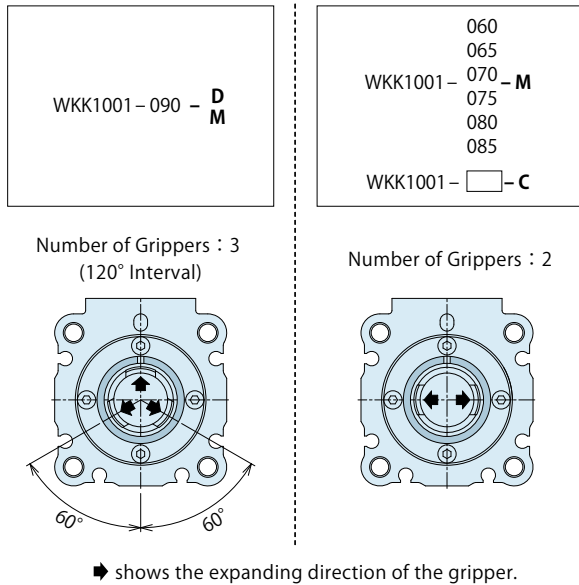

Mounting Direction of WKK1001-□

When locating with workpiece hole code **060 ~ 085**

- ※ Rotate 90° of the expanding direction of two hole grippers toward the line connecting the centers of two WKK1001-□-C. (Accuracy is not guaranteed since there is no reference locating.)

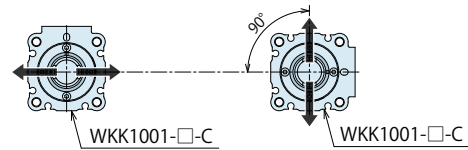

When locating with workpiece hole code **090**

- ※ The expanding direction of WKK1001□-C must be vertical toward the line connecting the centers of WKK1001-□-D and WKK1001-□-C.

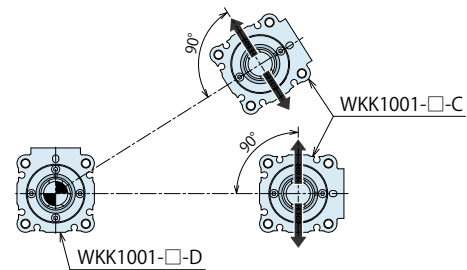

➡ shows the expanding direction of the gripper.

Model No. Indication

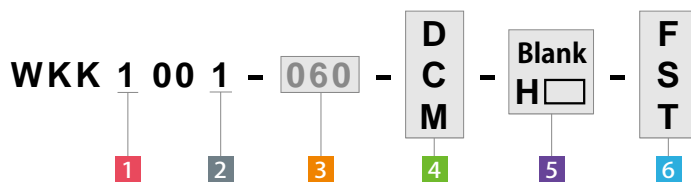

- 1 Body Size
- 2 Design No.
- 3 Workpiece Hole Diam. (Hole Code)
- 4 Functions
- 5 Seating Height Dimension
- 6 Shape of Gripper (Workpiece Hole)

External Dimension List

Model No.	WKK1001-□-□-□-□ (mm)							
Workpiece Hole Code	060 ^{※6}	065	070	075	080	085	090	
Workpiece Hole Diam. ϕd In case of 6 F,S ⁹	$6^{+0.7}_{-0.3}$	$6.5^{+0.7}_{-0.3}$	$7^{+0.7}_{-0.3}$	$7.5^{+0.7}_{-0.3}$	$8^{+0.7}_{-0.3}$	$8.5^{+0.7}_{-0.3}$	$9^{+0.7}_{-0.3}$	
Clamping Diameter At Release	5.5	6.0	6.5	7.0	7.5	8.0	8.5	
In case of 6 F,S At Idle	7.2	7.7	8.2	8.7	9.2	9.7	10.2	
Clamping Diameter At Release	-	5.7	6.2	6.7	7.2	7.7	8.2	
In case of 6 T At Idle	-	7.4	7.9	8.4	8.9	9.4	9.9	
Workpiece Pulling Stroke	1.0							
In case of 6 F,S	A	5.6	6.1	6.6	7.1	7.6	8.1	8.6
	B	8	8	8	8	8	8	9.5
	C	2	2	2.5	2.5	3	3	4.5
	E	3.3	3.3	3.3	3.3	3.3	3.3	4.3
In case of 6 T	A	-	6	6.5	7	7.5	8	8.6
	B	-	8	8	8	8	8	9.5
	C	-	2	2	2.5	2.5	3	4.5
	E	-	3.3	3.3	3.3	3.3	3.3	4.3
F	16	17	17	18	18	19	20	
G	10.5	11.5	11.5	12.5	12.5	13.5	14.5	
4 Function D Locating Repeatability ^{※7}	Not Available							0.03
4 Function M Allowable Offset (Floating Clearance of Expanding Area) ^{※8}	±0.3							

Notes : ^{※6} The workpiece hole diameter : **060** cannot be selected when selecting **6 T** : Taper Hole model.

^{※7} Locating repeatability under the same condition (no load).

^{※8} The expanding part is an adjusting structure and the clamping operation is done by locating a workpiece hole. The value in the table shows the amount of tolerance value of single hole gripper. Please consider the distance accuracy of each cylinder mounting hole and each workpiece machining hole when using with another location clamp / location cylinder, or when using more than two of these products.

^{※9} The allowable tolerance of workpiece hole mouth diameter varies depending on the slope angle in case of **T** : Taper Hole model. (Please refer to P.9.)

5 Seating Height Dimension	Standard	Specified				
	Blank	H10	H20	H30	H40	H50
AA	55	65	75	85	95	105
AB	8	18	28	38	48	58
Weight kg	0.38	0.40	0.42	0.44	0.46	0.48

External Dimensions

※ The drawing shows the released state of WKK1001-□-C-FB.

※ Expanding Area Detail

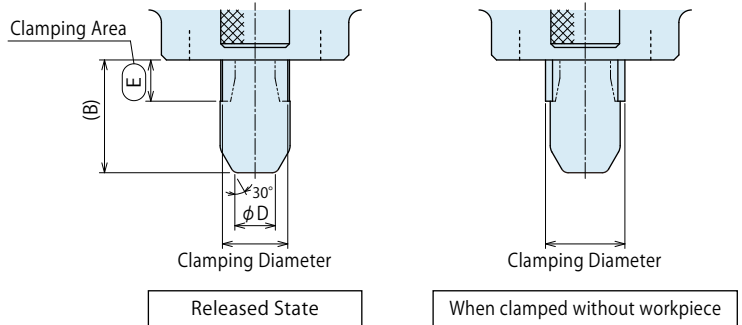
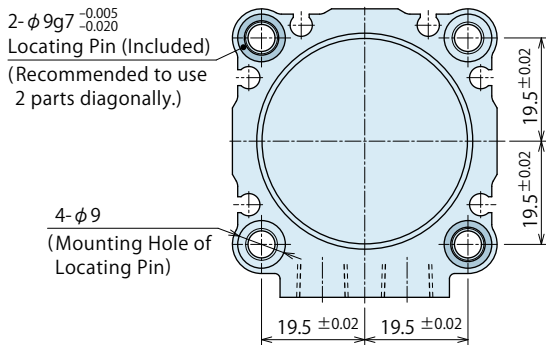

Seating Height: Standard

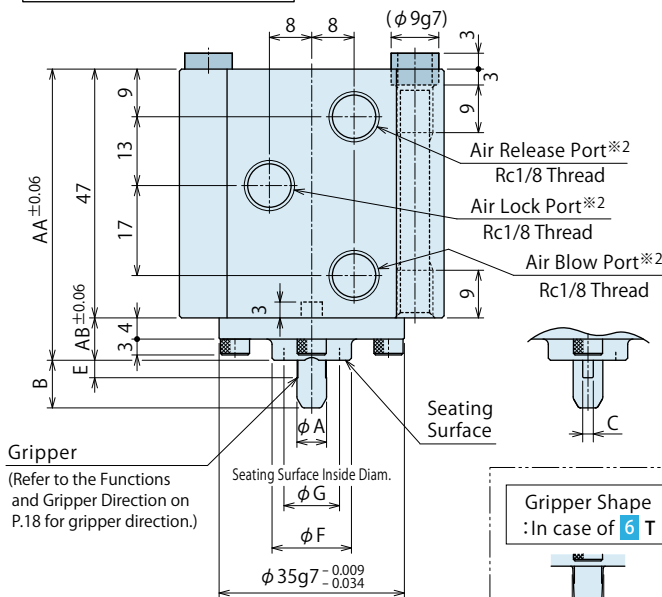

Specified Seating Height: H□※3

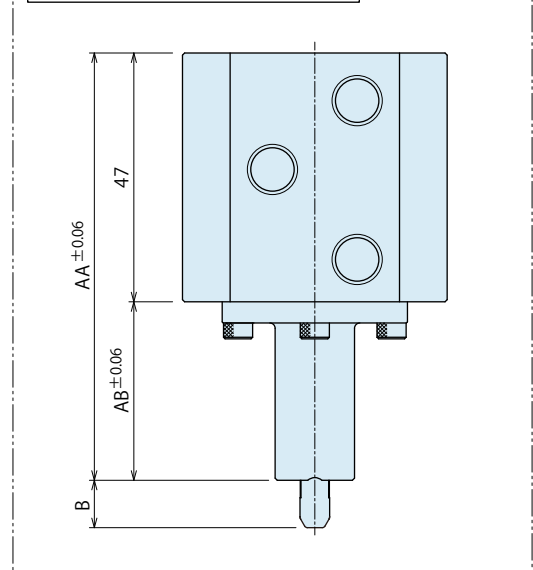

Notes :

1. Mounting bolts are not provided. Please prepare them according to the mounting position. (Refer to "Installation of Hole Gripper" on P.27.)
2. This product locks with air pressure and self-locking spring and releases with air pressure. (When air drops to 0MPa, it will be in the locked state with gripper expansion.)

- ※1. The workpiece must be resting on all seating surfaces when clamping. Otherwise the workpiece can be deformed by the clamping force.
- ※2. The name of each port is marked on the port. (LOCK: Air Lock Port, RELEASE: Air Release Port, BLOW: Air Blow Port) Continuously supply air pressure to the air blow port when in use.

※3. Please refer to the drawing on the left side : Seating Height: Standard for unlisted dimensions.

※4. For -T: Taper Hole model, the first gripper ridge is the reference diameter.

Machining Dimensions of Workpiece (Pallet) Hole

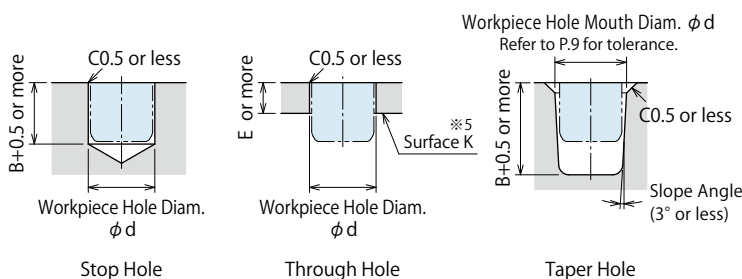

Notes :

1. Thin wall around the workpiece hole can be deformed by clamping action, gripping force and clamping force will not fill the specification. Please make sure to test the clamping function before using and adjust to the appropriate supply of pressure.
- ※5. When the hole gripper head is sticking above the surface K of the workpiece, please make sure there is no interference with the hole gripper during machining.

Functions and Gripper Direction

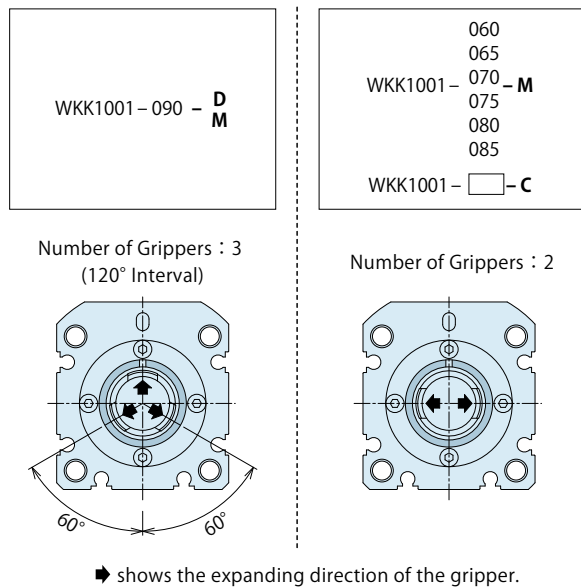

Mounting Direction of WKK1001-□

When locating with workpiece hole code **060 ~ 085**

- ※ Rotate 90° of the expanding direction of two hole grippers toward the line connecting the centers of two WKK1001-□-C. (Accuracy is not guaranteed since there is no reference locating.)

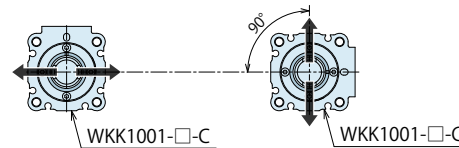

When locating with workpiece hole code **090**

- ※ The expanding direction of WKK1001-□-C must be vertical toward the line connecting the centers of WKK1001-□-D and WKK1001-□-C.

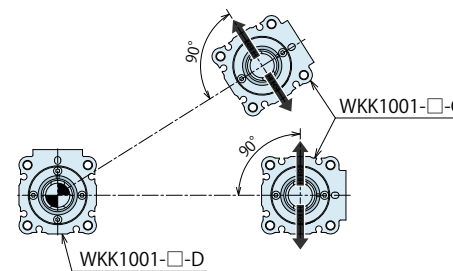

▶ shows the expanding direction of the gripper.

Model No. Indication

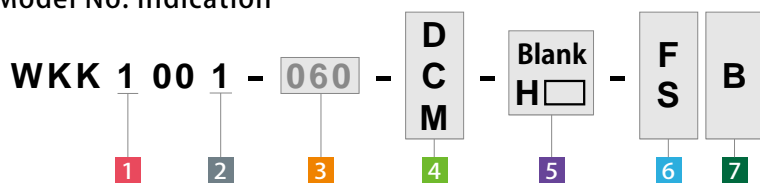

- 1 Body Size
- 2 Design No.
- 3 Workpiece Hole Diam. (Hole Code)
- 4 Functions
- 5 Seating Height Dimension
- 6 Shape of Gripper (Workpiece Hole)
- 7 Shape of Cap End (In case of B)

External Dimension List

Model No.		WKK1001-□-□-□-□B (mm)							
3 Workpiece Hole Code		060 ^{※6}	065	070	075	080	085	090	
Workpiece Hole Diam. φd	In case of 6 F,S ^{※9}	6 ^{+0.7} _{-0.3}	6.5 ^{+0.7} _{-0.3}	7 ^{+0.7} _{-0.3}	7.5 ^{+0.7} _{-0.3}	8 ^{+0.7} _{-0.3}	8.5 ^{+0.7} _{-0.3}	9 ^{+0.7} _{-0.3}	
Clamping Diameter	At Release	5.5	6.0	6.5	7.0	7.5	8.0	8.5	
	In case of 6 F,S	7.2	7.7	8.2	8.7	9.2	9.7	10.2	
Clamping Diameter	At Release	-	5.7	6.2	6.7	7.2	7.7	8.2	
	In case of 6 T	-	7.4	7.9	8.4	8.9	9.4	9.9	
Workpiece Pulling Stroke		1.0							
In case of 6 F,S	A	5.6	6.1	6.6	7.1	7.6	8.1	8.6	
	B	9	9	9	10	10	10	11	
	C	2	2	2.5	2.5	3	3	4.5	
	D	3.5	4	4.5	4	4.5	5	5.4	
	E	3.3	3.3	3.3	3.3	3.3	3.3	4.3	
In case of 6 T	A	-	6	6.5	7	7.5	8	8.6	
	B	-	9	9	9	10	10	11	
	C	-	2	2	2.5	2.5	3	4.5	
	D	-	3.2	3.7	4.2	3.6	4.1	5.2	
	E	-	3.3	3.3	3.3	3.3	3.3	4.3	
F		16	17	17	18	18	19	20	
G		10.5	11.5	11.5	12.5	12.5	13.5	14.5	
4 Function D	Locating Repeatability ^{※7}	Not Available							0.03
4 Function M	Allowable Offset (Floating Clearance of Expanding Area) ^{※8}	±0.3							

Notes : ※6. The workpiece hole diameter : **060** cannot be selected when selecting **6 T** : Taper Hole model.

※7. Locating repeatability under the same condition (no load).

※8. The expanding part is an adjusting structure and the clamping operation is done by locating a workpiece hole. The value in the table shows the amount of tolerance value of single hole gripper. Please consider the distance accuracy of each cylinder mounting hole and each workpiece machining hole when using with another location clamp / location cylinder, or when using more than two of these products.

※9. The allowable tolerance of workpiece hole mouth diameter varies depending on the slope angle in case of **T** : Taper Hole model. (Please refer to P.9.)

5 Seating Height Dimension	Standard		Specified			
	Blank	H10	H20	H30	H40	H50
AA	55	65	75	85	95	105
AB	8	18	28	38	48	58
Weight kg	0.38	0.40	0.42	0.44	0.46	0.48

External Dimensions

※ The drawing shows the released state of WKK2001-□-D-F.

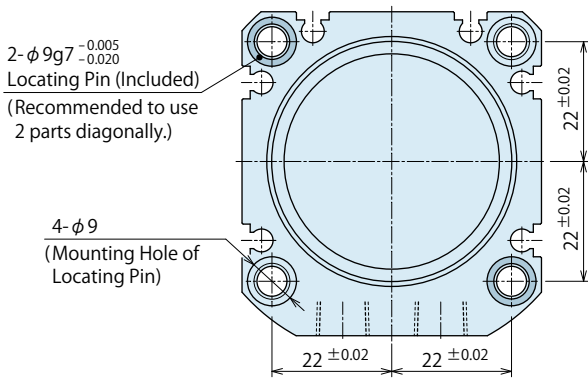

Expanding Area Detail

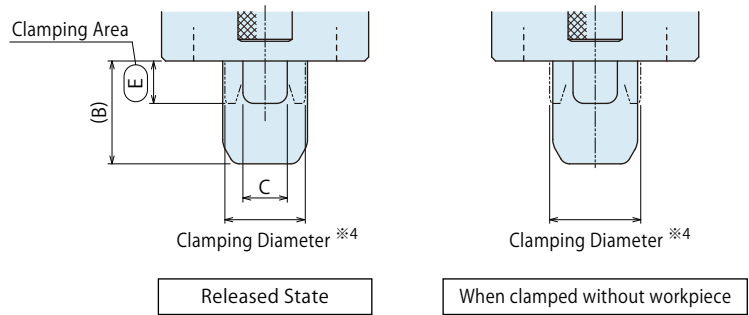

Seating Height: Standard

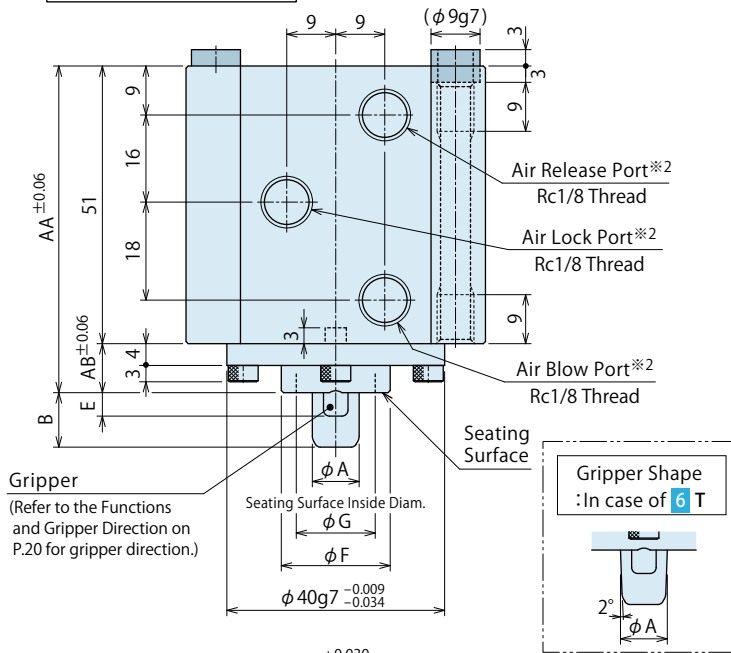

Specified Seating Height: H □ ※3

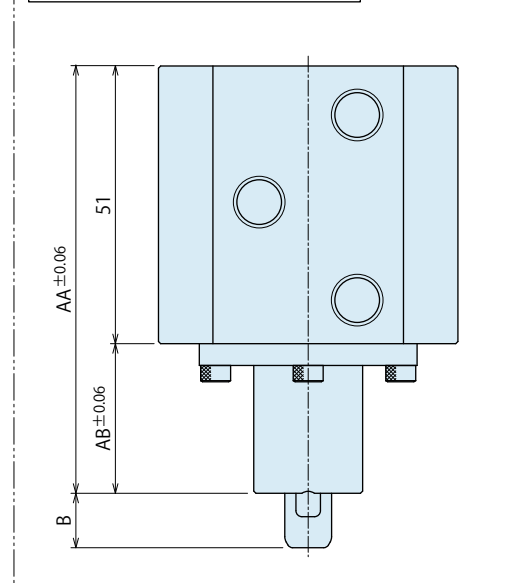

Notes :

1. Mounting bolts are not provided. Please prepare them according to the mounting position. (Refer to "Installation of Hole Gripper" on P.27.)
2. This product locks with air pressure and self-locking spring and releases with air pressure. (When air drops to OMPa, it will be in the locked state with gripper expansion.)
- ※1. The workpiece must be resting on all seating surfaces when clamping. Otherwise the workpiece can be deformed by the clamping force.
- ※2. The name of each port is marked on the port. (LOCK: Air Lock Port, RELEASE: Air Release Port, BLOW: Air Blow Port) Continuously supply air pressure to the air blow port when in use.
- ※3. Please refer to the drawing on the left side : Seating Height: Standard for unlisted dimensions.
- ※4. For -T: Taper Hole model, the first gripper ridge is the reference diameter.

Machining Dimensions of Workpiece (Pallet) Hole

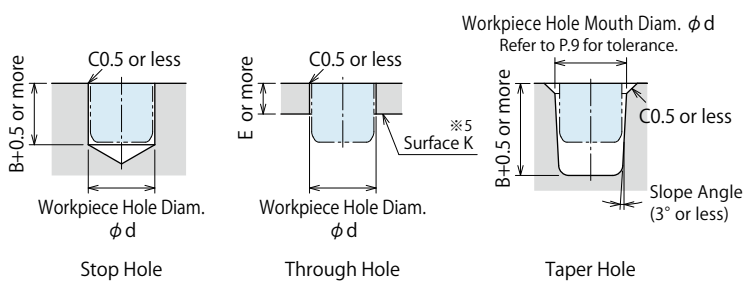

Notes :

1. Thin wall around the workpiece hole can be deformed by clamping action, gripping force and clamping force will not fill the specification. Please make sure to test the clamping function before using and adjust to the appropriate supply of pressure.
- ※5. When the hole gripper head is sticking above the surface K of the workpiece, please make sure there is no interference with the hole gripper during machining.

Functions and Gripper Direction

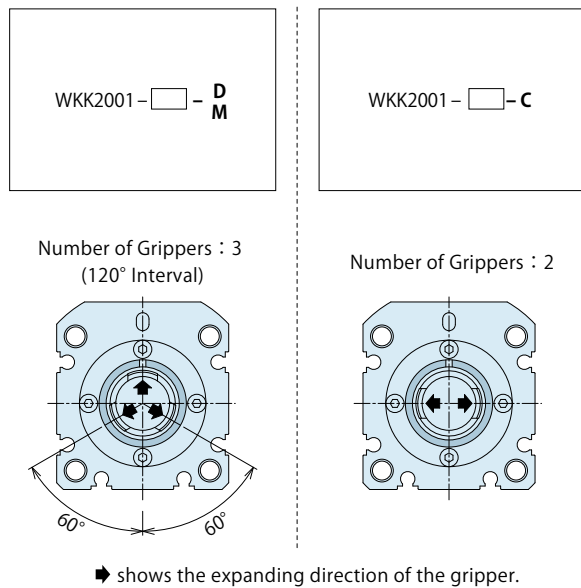

Mounting Direction of WKK2001-□-C

※ The expanding direction of WKK2001-□-C must be vertical toward the line connecting the centers of WKK2001-□-D and WKK2001-□-C.

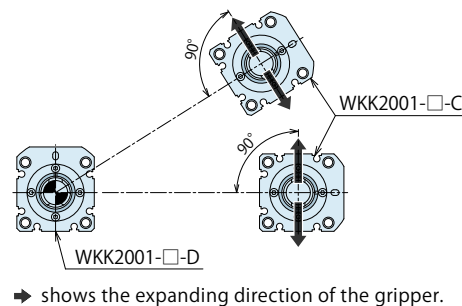

Model No. Indication

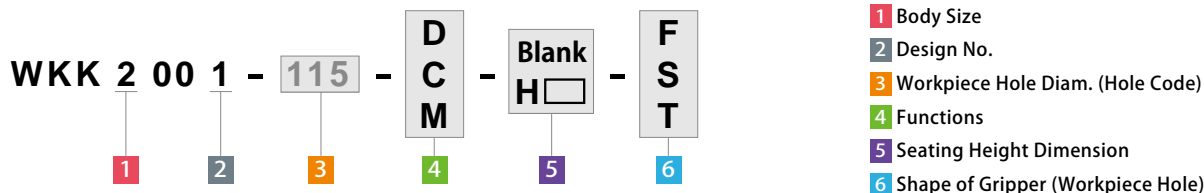

External Dimension List

Model No.		WKK2001-□-□-□-□ (mm)								
3 Workpiece Hole Code		090	095	100	105	110	115	120	125	130
Workpiece Hole Diam. ϕd	In case of 6 F,S ^{※8}	$9^{+0.7}_{-0.3}$	$9.5^{+0.7}_{-0.3}$	$10^{+0.7}_{-0.3}$	$10.5^{+0.7}_{-0.3}$	$11^{+0.7}_{-0.3}$	$11.5^{+0.7}_{-0.3}$	$12^{+0.7}_{-0.3}$	$12.5^{+0.7}_{-0.3}$	$13^{+0.7}_{-0.3}$
Clamping Diameter	At Release	8.5	9.0	9.5	10.0	10.5	11.0	11.5	12.0	12.5
	In case of 6 F,S	At Idle	10.2	10.7	11.2	11.7	12.2	12.7	13.2	13.7
Clamping Diameter	At Release	8.2	8.5	9	9.5	9.95	10.45	10.95	11.45	11.95
	In case of 6 T	At Idle	9.9	10.2	10.7	11.2	11.65	12.15	12.65	13.15
Workpiece Pulling Stroke		1.0								
In case of 6 F,S	A	8.6	9.1	9.6	10.1	10.6	11.1	11.6	12.1	12.6
	B	10	10	10	11.5	11.5	11.5	11.5	11.5	11.5
	C	4.5	4.5	5	5	5.5	5.5	6	6	6.5
	E	4.3	4.3	4.3	5.8	5.8	5.8	5.8	5.8	5.8
In case of 6 T	A	8.6	9	9.5	10	10.4	10.9	11.4	11.9	12.4
	B	10	10	10	10	11.5	11.5	11.5	11.5	11.5
	C	4.5	4.5	4.5	5	5	5	5.5	5.5	6
	E	4.3	4.3	4.3	4.3	5.8	5.8	5.8	5.8	5.8
F		21	22	22	23	23	24	24	25	25
G		14.5	15.5	15.5	16.5	16.5	17.5	17.5	18.5	18.5
4 Function D Locating Repeatability ^{※6}		0.03								
4 Function M Allowable Offset (Floating Clearance of Expanding Area) ^{※7}		±0.5								

Notes : ※6. Locating repeatability under the same condition (no load).

※7. The expanding part is an adjusting structure and the clamping operation is done by locating a workpiece hole. The value in the table shows the amount of tolerance value of single hole gripper. Please consider the distance accuracy of each cylinder mounting hole and each workpiece machining hole when using with another location clamp / location cylinder, or when using more than two of these products.

※8. The allowable tolerance of workpiece hole mouth diameter varies depending on the slope angle in case of T : Taper Hole model. (Please refer to P.9.)

5 Seating Height Dimension	Standard	Specified				
	Blank	H10	H20	H30	H40	H50
AA	60	70	80	90	100	110
AB	9	19	29	39	49	59
Weight kg	0.50	0.54	0.57	0.60	0.64	0.67

External Dimensions

※ The drawing shows the released state of WKK2001-□-D-FB.

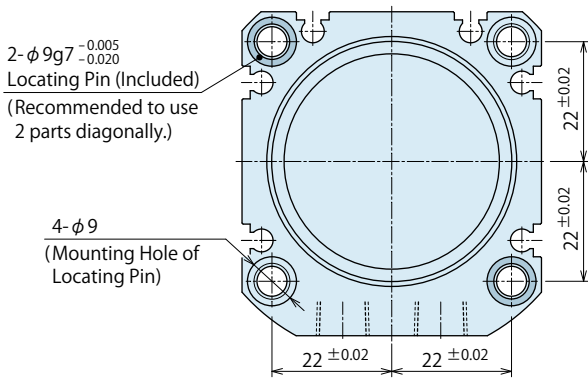

Expanding Area Detail

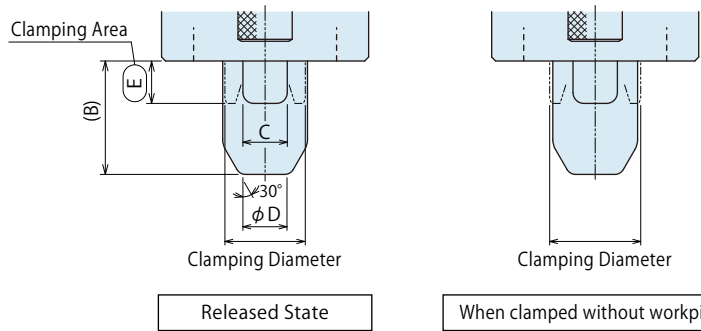

Seating Height: Standard

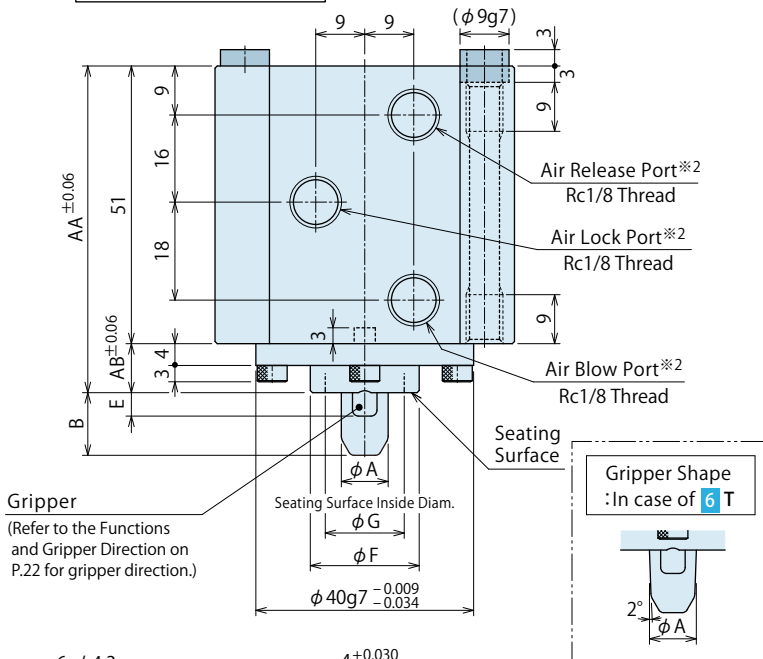

Specified Seating Height: H □ *3

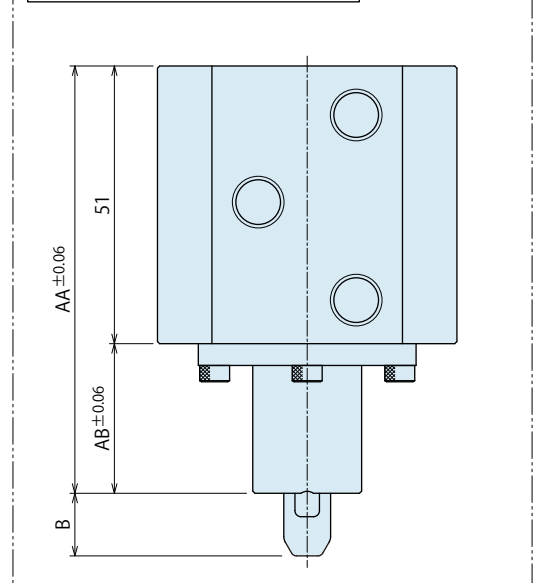

Notes :

1. Mounting bolts are not provided. Please prepare them according to the mounting position. (Refer to "Installation of Hole Gripper" on P.27.)
 2. This product locks with air pressure and self-locking spring and releases with air pressure. (When air drops to 0MPa, it will be in the locked state with gripper expansion.)
- ※1. The workpiece must be resting on all seating surfaces when clamping. Otherwise the workpiece can be deformed by the clamping force.
- ※2. The name of each port is marked on the port. (LOCK: Air Lock Port, RELEASE: Air Release Port, BLOW: Air Blow Port) Continuously supply air pressure to the air blow port when in use.
- ※3. Please refer to the drawing on the left side : Seating Height: Standard for unlisted dimensions.
- ※4. For -T: Taper Hole model, the first gripper ridge is the reference diameter.

Machining Dimensions of Workpiece (Pallet) Hole

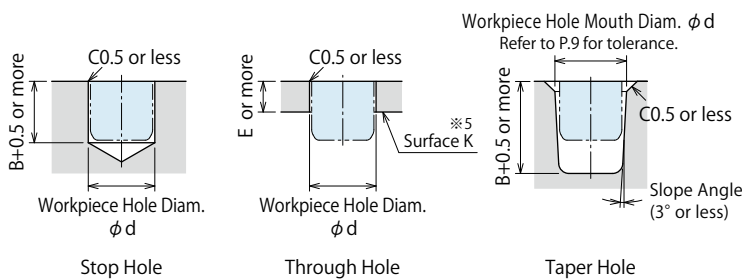

Notes :

1. Thin wall around the workpiece hole can be deformed by clamping action, gripping force and clamping force will not fill the specification. Please make sure to test the clamping function before using and adjust to the appropriate supply of pressure.
- ※5. When the hole gripper head is sticking above the surface K of the workpiece, please make sure there is no interference with the hole gripper during machining.

Functions and Gripper Direction

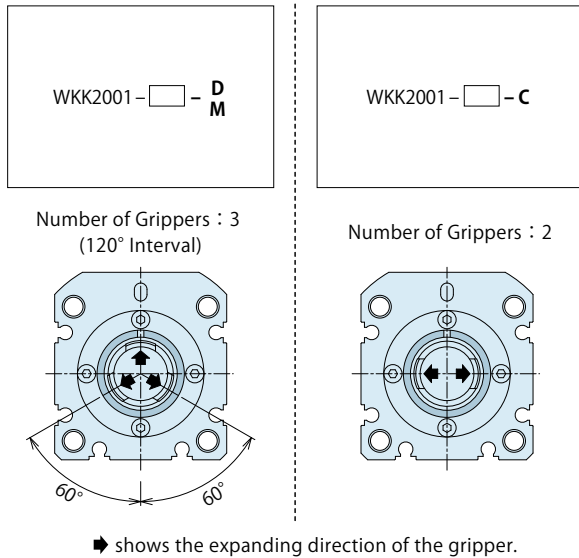

Mounting Direction of WKK2001-□-C

※ The expanding direction of WKK2001-□-C must be vertical toward the line connecting the centers of WKK2001-□-D and WKK2001-□-C.

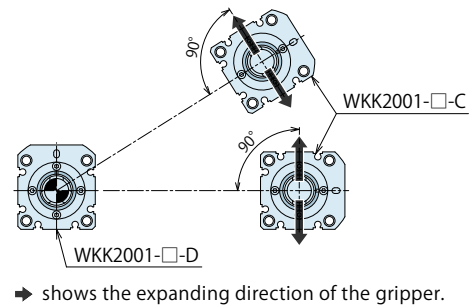

Model No. Indication

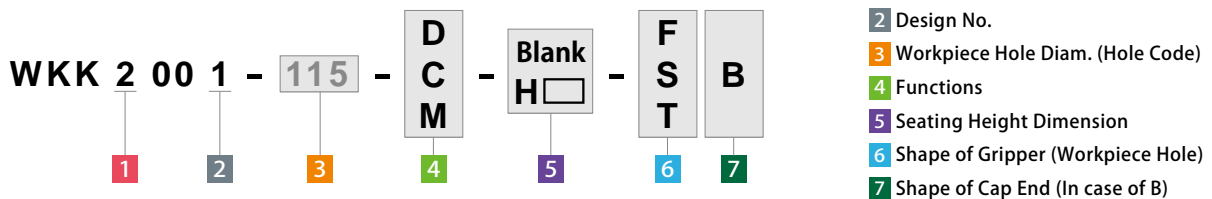

External Dimension List

Model No.		WKK2001-□-□-□-□B								
3 Workpiece Hole Code		090	095	100	105	110	115	120	125	130
Workpiece Hole Diam. ϕd	In case of 6 F,S ^{※8}	$9^{+0.7}_{-0.3}$	$9.5^{+0.7}_{-0.3}$	$10^{+0.7}_{-0.3}$	$10.5^{+0.7}_{-0.3}$	$11^{+0.7}_{-0.3}$	$11.5^{+0.7}_{-0.3}$	$12^{+0.7}_{-0.3}$	$12.5^{+0.7}_{-0.3}$	$13^{+0.7}_{-0.3}$
Clamping Diameter	At Release	8.5	9.0	9.5	10.0	10.5	11.0	11.5	12.0	12.5
In case of 6 F,S	At Idle	10.2	10.7	11.2	11.7	12.2	12.7	13.2	13.7	14.2
Clamping Diameter	At Release	8.2	8.5	9	9.5	9.95	10.45	10.95	11.45	11.95
In case of 6 T	At Idle	9.9	10.2	10.7	11.2	11.65	12.15	12.65	13.15	13.65
Workpiece Pulling Stroke		1.0								
In case of 6 F,S	A	8.6	9.1	9.6	10.1	10.6	11.1	11.6	12.1	12.6
	B	11.5	11.5	11.5	13.5	13.5	13.5	13.5	14.5	14.5
	C	4.5	4.5	5	5	5.5	5.5	6	6	6.5
	D	5.2	5.7	6.2	6.1	6.6	7.1	7.6	6.9	7.4
	E	4.3	4.3	4.3	5.8	5.8	5.8	5.8	5.8	5.8
In case of 6 T	A	8.6	9	9.5	10	10.4	10.9	11.4	11.9	12.4
	B	11.5	11.5	11.5	11.5	13.5	13.5	13.5	13.5	14.5
	C	4.5	4.5	4.5	5	5	5	5.5	5.5	6
	D	4.6	4.9	5.4	5.9	5.7	6.2	6.7	7.2	6.5
	E	4.3	4.3	4.3	4.3	5.8	5.8	5.8	5.8	5.8
F		21	22	22	23	23	24	24	25	25
G		14.5	15.5	15.5	16.5	16.5	17.5	17.5	18.5	18.5
4 Function D	Locating Repeatability ^{※6}	0.03								
4 Function M	Allowable Offset (Floating Clearance of Expanding Area) ^{※7}	± 0.5								

Notes : ※6. Locating repeatability under the same condition (no load).

※7. The expanding part is an adjusting structure and the clamping operation is done by locating a workpiece hole. The value in the table shows the amount of tolerance value of single hole gripper. Please consider the distance accuracy of each cylinder mounting hole and each workpiece machining hole when using with another location clamp / location cylinder, or when using more than two of these products.

※8. The allowable tolerance of workpiece hole mouth diameter varies depending on the slope angle in case of T : Taper Hole model. (Please refer to P.9.)

5 Seating Height Dimension	(mm)					
	Standard	Specified				
	Blank	H10	H20	H30	H40	H50
AA	60	70	80	90	100	110
AB	9	19	29	39	49	59
Weight kg	0.50	0.54	0.57	0.60	0.64	0.67

● Sample 1 (Layout and Circuit)

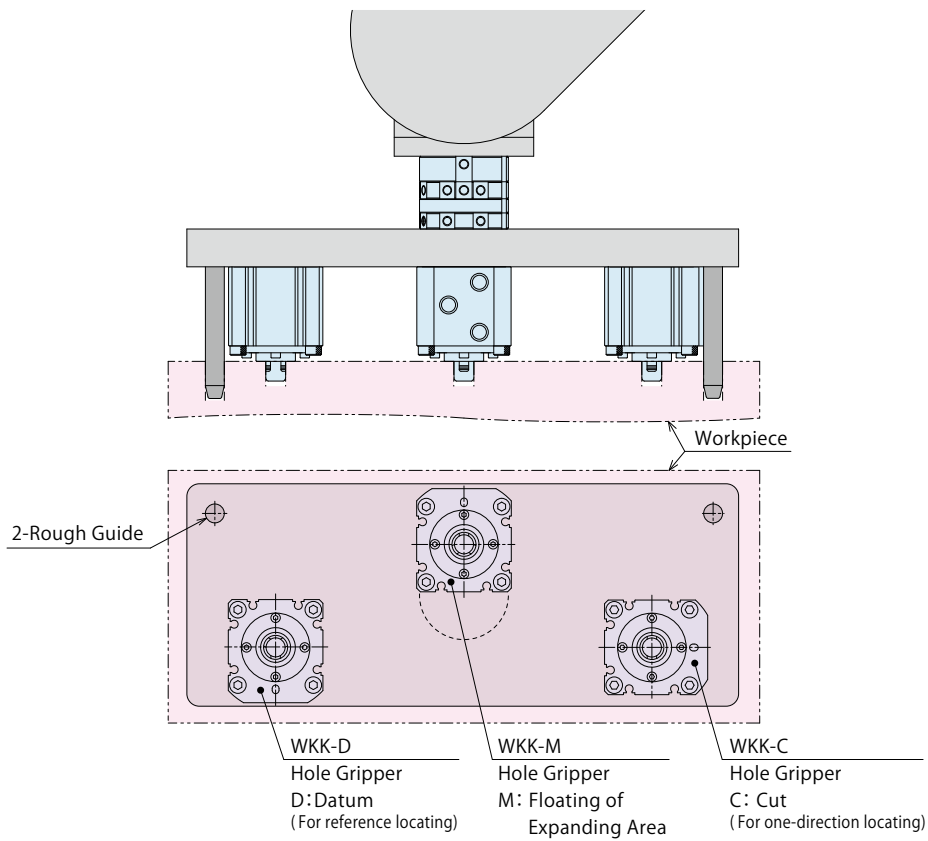

Note :

1. When loading/unloading a workpiece, install 2 or more rough guides in order to prevent damage to a clamping part.

Circuit Example

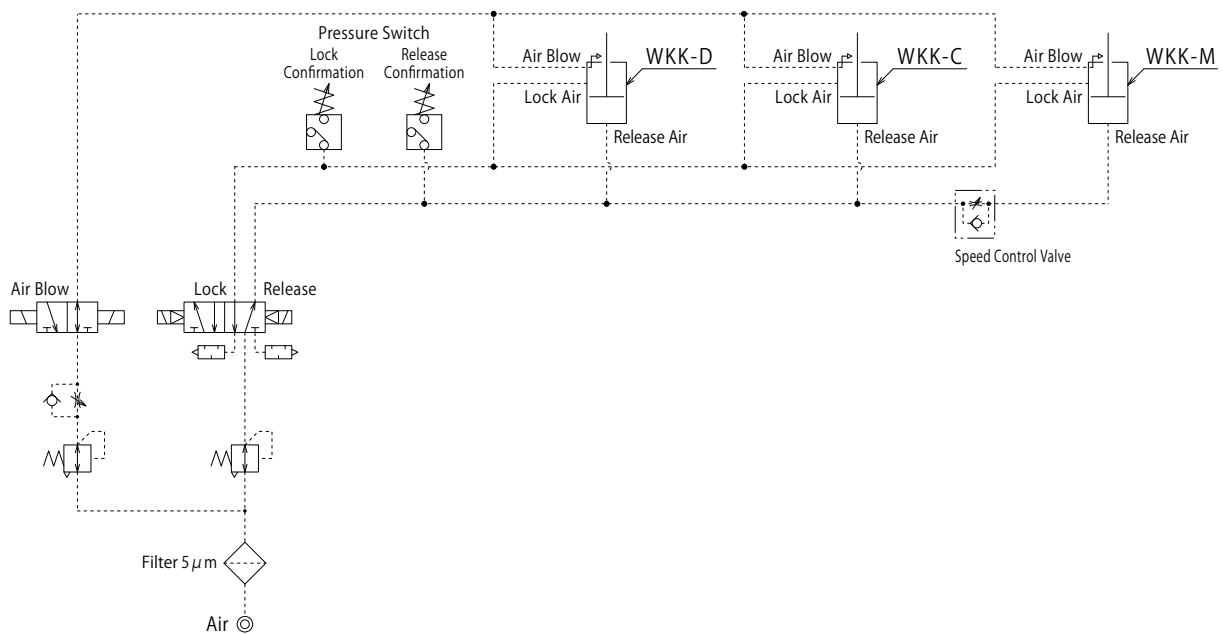

Sample 2 (Layout and Circuit)

Combination Use with High-Power Pneumatic Work Support (model WNC) for Workpiece Inclination Prevention During Transfer

When the gravity center of a workpiece is unbalanced, it could damage the hole gripper or drop a workpiece affected by inertia moment due to high-speed transfer (sudden stop). Use work supports, etc. when designing a system.

※ This drawing shows a layout sample of WKK-D/C (Hole Gripper), WNC (High-Power Pneumatic Work Support) and BWD (Air Sequence Valve).

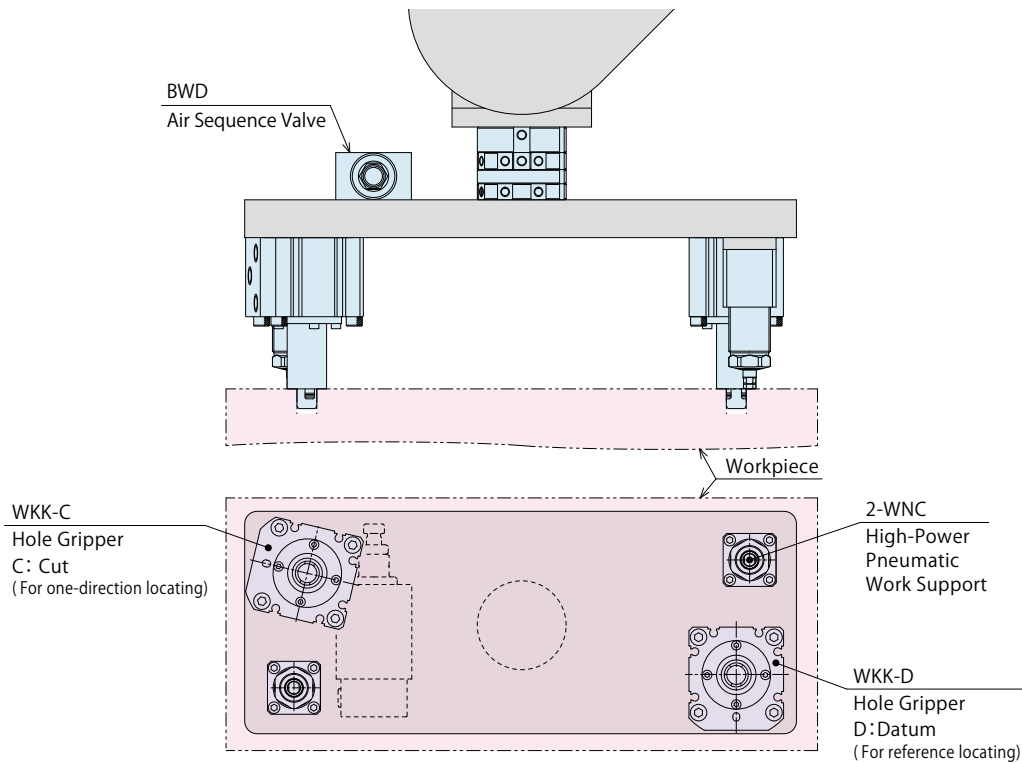

When Controlled with One Solenoid Valve

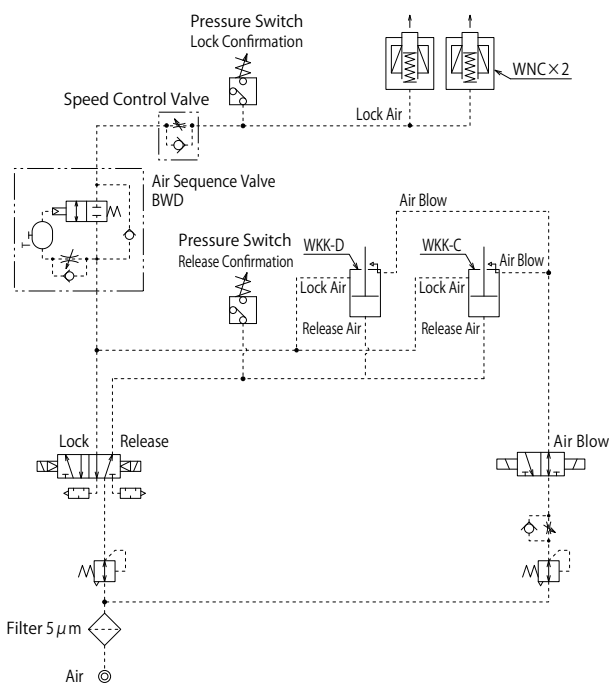

When Controlled with Two Solenoid Valves

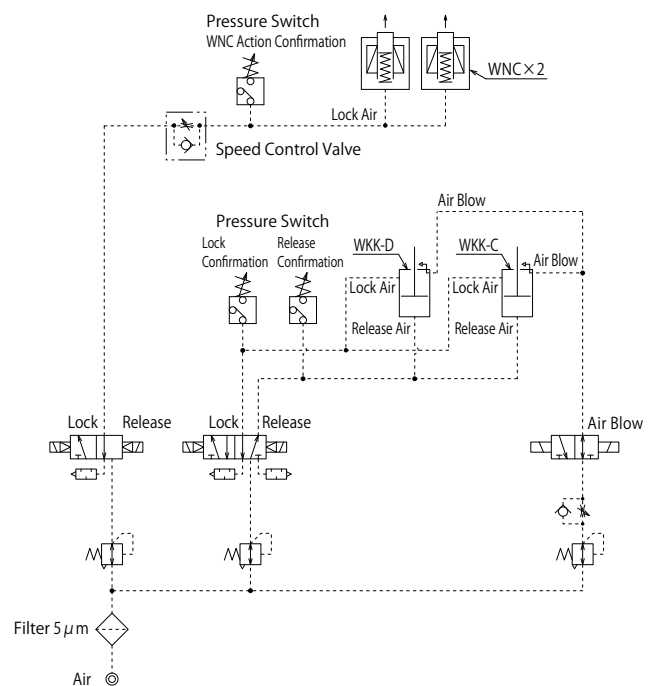

Note :

1. Please use solenoid valve or BWD (Air Sequence Valve) to make a sequence operation that WKK (Hole Gripper) starts working after WNC (High-Power Pneumatic Work Support) completes the movement. If WKK activates after WNC completes operation, a workpiece can be projected out, leading to damage on WKK, a workpiece fall and seating malfunction.

Cautions

● Notes for Design

1) Check Specifications

- Please use each product according to its specifications.
- This product is an air double-acting cylinder which locks with air pressure and spring force (gripping and clamping), and releases with air pressure. Even when air is not supplied to either lock or release port, the self-lock spring maintains clamped state (clamping diameter is expanded).
- ① Gripping force and clamping force at 0MPa are lower than those when air is supplied. For using at zero pressure, please refer to P.13 Gripping • Clamping Force Curve : Air Pressure 0 MPa.
- ② Supply the release air when loading/unloading a workpiece. Otherwise the workpiece contacts the hole gripper leading to damage to the workpiece and the hole gripper.

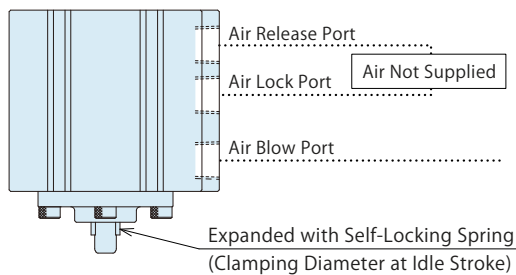

2) Working Reference Plate (Seating Surface) Z Axis

- The upper surface of the flange of this product is the seating surface of workpiece and locates in Z direction.

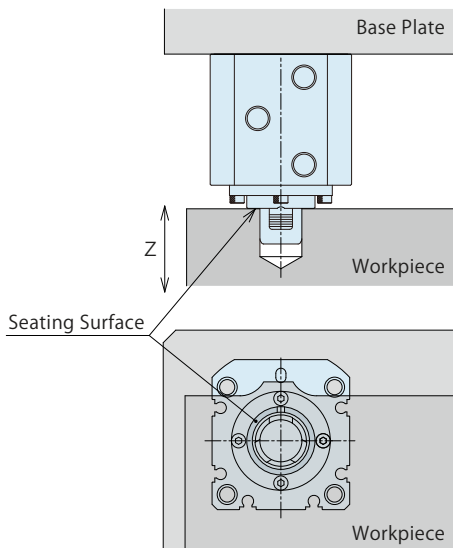

A workpiece must be resting on all seating surfaces when clamping. If not, calculate contacting pressure with clamping force and seating area not to deform a workpiece.

3) Wall Thickness around Workpiece Hole

- Thin wall around the workpiece hole can be deformed by clamping action, gripping and clamping forces do not fill the specification. Please conduct clamping test and adjust to proper air pressure before use. If clamping force is insufficient, workpiece may fall out.

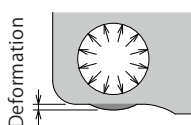

4) Hole Gripper Installation

- When Using Functions -D/C

-C : Cut locates the orientation using -D : Datum as a reference. Therefore, it is required to determine the phase of -C : Cut when mounting.

When locating with workpiece hole code **090 ~ 130**
(When using Function -D and -C together)

The expanding direction of WKK-□-C must be vertical toward the line connecting the centers of WKK-□-D and WKK-□-C.

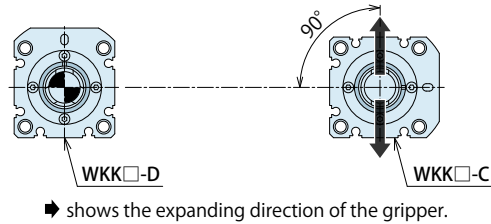

When roughly locating with workpiece hole code **060 ~ 085**
(When using Function -C and -C together)

Rotate 90° of the expanding direction of two cylinders toward the line connecting the centers of two WKK1001-□-C. (Accuracy is not guaranteed since there is no reference locating.)

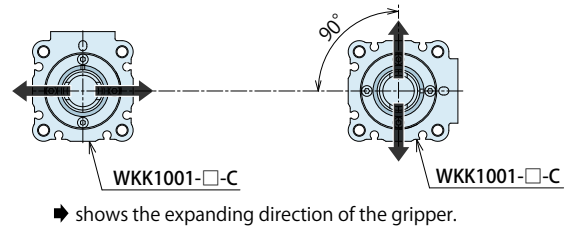

- When Using Function -M : Floating of Expanding Area

-M has the floating function (WKK1001 : ±0.3mm, WKK2001 : ±0.5mm). Please consider the distance accuracy of each hole gripper mounting hole and each workpiece machining hole when using with another location clamp / location cylinder, or when using more than two of these products.

5) Clamping Force

- Clamping force shows the force that pulls a workpiece onto the seating surface. Please conduct clamping test and adjust to proper air pressure before use. Insufficient clamping force causes a workpiece to fall.

6) Workpiece hole size, slope angle and workpiece hardness should be within the range of the specification.

When workpiece hole diameter is larger than specification.	Leads to insufficient expansion stroke. Gripping force and clamping force will not fill the specifications.
When using it with insufficient gripping (clamping) force.	Leads to falling of the workpiece.
When workpiece hole diameter is smaller than specification.	Difficult to attach/detach the workpiece leading to damage to the hole gripper.
When workpiece hole depth is shallow.	May lead to abnormal seating and damage to the hole gripper.
When workpiece hole taper is larger than standard.	May cause gripping malfunction leading to a workpiece fall.
When workpiece hole is harder than specified. (" with serration" only)	Gripper does not dig into a workpiece enough and it cannot clamp securely.

7) Horizontal Locating

- When a workpiece is set, please make sure there is no lifting or slope of the workpiece. If the clamping operation is done with lifting or slope of the workpiece, it will lead to possible damage of the gripper and deformation of the workpiece hole.

8) Please detach a workpiece with all grippers fully released.

- When detaching a workpiece during lock or release operation, it may cause damage to the hole gripper and a workpiece fall.

9) Please set up rough guides.

- When detaching a workpiece with slope it may cause the damage to the hole gripper and a workpiece fall.

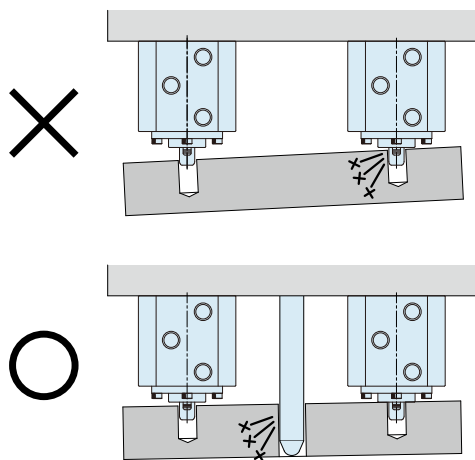

Please set up rough guides considering the pitch accuracy of location clamp / location cylinder mounting hole and each workpiece machining hole when using with another location clamp / location cylinder, etc.

10) For Use of Auto Switch

- Select an auto switch depending on the environment.
- An auto switch may be stuck out of the Hole Gripper depending on the installation position and direction.
- **2-wire reed auto switch cannot be used.**
- Depending on difference of workpiece hole diameters, the detection range of an auto switch can be insufficient.
If using an auto switch, workpiece hole diameter difference should be within $\pm 0.3\text{mm}$.

11) Fall Prevention Measures

- In case of accident such as detachment of a workpiece, please prepare fall prevention measures for safety.

12) Air Blow Port

- Continuously supply air pressure to the air blow port. Using without air supply causes contaminants entering into the hole gripper leading to clamping malfunction.

13) Damage Prevention during Robot Handling, etc.

- When inserting the Hole Gripper tip into/taking it out of a workpiece hole, the Hole Gripper tip has to be vertical to the workpiece hole.

Especially after releasing a workpiece, the Hole Gripper tip must be fully taken out from the workpiece hole before moving to a next coordinate.

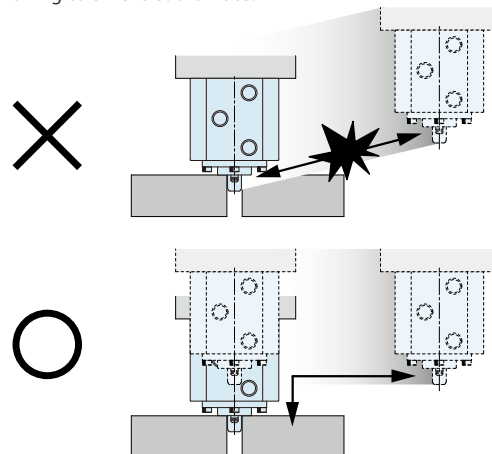

- If the Hole Gripper tip touches a workpiece when inserting, control the insertion speed to avoid damage on the workpiece and Hole Gripper tip.

- When the Hole Gripper is mounting/removing a workpiece, make sure that a robot operates only after the Gripper completes locking or releasing action by using a sensor or timer.

If the robot starts operating in the middle of locking or releasing action, the workpiece may be fallen off.

- When mounting/removing a workpiece, it may be tilted due to a gap between the workpiece and the stand. This causes damage of the Hole Gripper. The gap has to be minimized as much as possible when mounting/removing.

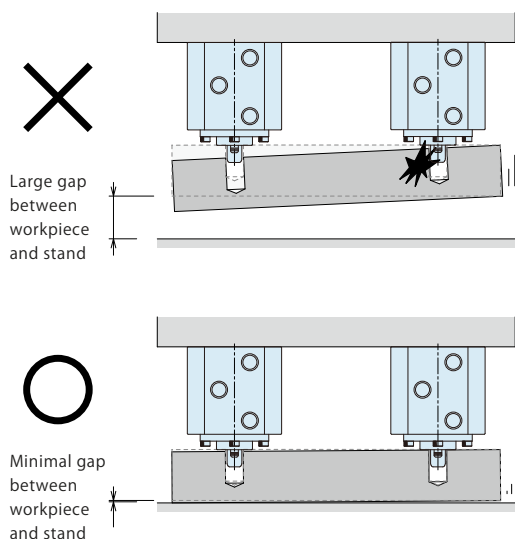

Cautions

Installation Notes

- 1) Check the fluid to use.
 - Please supply filtered clean dry air.
 - Oil supply with a lubricator etc. is unnecessary.
- 2) Preparation for Piping
 - The pipeline, piping connector and fixture circuits should be cleaned and flushed thoroughly. The dust and cutting chips in the circuit may lead to fluid leakage and malfunction.
 - There is no filter provided with this product for prevention of contaminants in the air circuit.
- 3) Applying Sealing Tape
 - Wrap with tape 1 to 2 times following the screwing direction.
 - Pieces of the sealing tape may lead to air leaks and malfunction.
 - In order to prevent contaminants from entering into the product during the piping work, it should be carefully cleaned before working.
- 4) Mounting Hole Gripper
 - When mounting the product use four hexagonal socket bolts (with tensile strength of A2-70 or more) and tighten them with the torque shown in the list below. Tightening with greater torque than recommended can depress the seating surface or break the bolt.

Model	Mounting Bolt Size	Tightening Torque (N·m)
WKK	M5×0.8	5.0
	M6×1	8.0

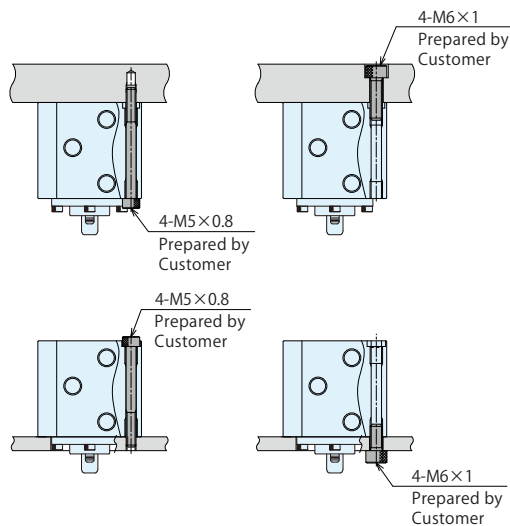

Notes on Handling

- 1) It should be operated by qualified personnel.
 - The hydraulic machine and air compressor should be operated and maintained by qualified personnel.
- 2) Do not operate or remove the product unless the safety protocols are ensured.
 - ① The machine and equipment can only be inspected or prepared when it is confirmed that the safety devices are in place.
 - ② Before the product is removed, make sure that the above-mentioned safety devices are in place. Shut off the pressure and power source, and make sure no pressure exists in the air and hydraulic circuits.
 - ③ After stopping the product, do not remove until the temperature drops.
 - ④ Make sure there is no trouble/issue in the bolts and respective parts before restarting the machine or equipment.
- 3) Do not touch workpieces (pallets) or hole grippers while they are working. Otherwise, your hands may be injured.

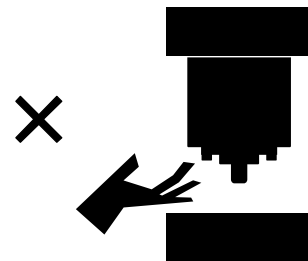

- 4) When transferring a workpiece, make sure the safety of environment in case of an accidental workpiece detachment.
- 5) Do not disassemble or modify.
 - If the product is taken apart or modified, the warranty will be voided even within the warranty period.
 - Powerful spring is built in inside which is very dangerous.

● Maintenance and Inspection

- 1) Removal of the Product and Shut-off of Pressure Source
 - Before removing the product, make sure that safety devices and preventive devices are in place. Shut off the pressure and power source, and make sure no pressure exists in the air and hydraulic circuits.
 - Make sure there is no trouble/issue in the bolts and respective parts before restarting.

- 2) Regularly clean the clamping part and seating surface.
 - If operating with dirt adhering to the clamping part, it will lead to damage to a product and a workpiece fall due to insufficient gripping force and clamping force, locating malfunction and air leakage, etc.

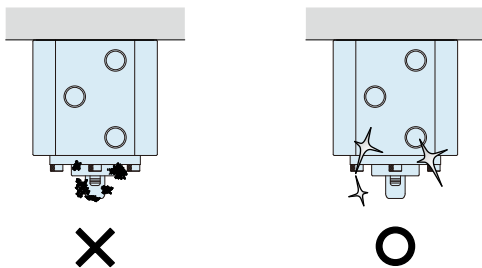

- 3) Regularly tighten pipe line and mounting bolt to ensure proper use.
- 4) Clamping force will be decreased by friction of a gripper surface due to repeated operation. Replacement period differs depending on operating pressure, workpiece material and shape of hole. When you find friction on gripper surface, the gripper needs to be replaced. Please contact us for overhaul.

Material of Clamping Hole	Gripper Replacement Frequency Guide
A2017 Aluminum	Locking operation 1 million cycles
SCM435 Thermal Refined Steel	Locking operation 500,000 cycles

※ It varies depending on the operating conditions. Please request an overhaul after confirming its suitability for the actual machine.

- 5) Make sure there is a smooth action without an irregular noise.
 - Especially when it is restarted after left unused for a long period, make sure it can be operated correctly.
- 6) The products should be stored in the cool and dark place without direct sunshine or moisture.
- 7) Please contact us for overhaul and repair.

Powerful spring is built in inside which is very dangerous.

● Warranty

- 1) Warranty Period
 - The product warranty period is 18 months from shipment from our factory or 12 months from initial use, whichever is earlier.
- 2) Warranty Scope
 - If the product is damaged or malfunctions during the warranty period due to faulty design, materials or workmanship, we will replace or repair the defective part at our expense. Defects or failures caused by the following are not covered.
 - ① If the stipulated maintenance and inspection are not carried out.
 - ② If the product is used while it is not suitable for use based on the operator's judgment, resulting in defect.
 - ③ If it is used or operated in an inappropriate way by the operator. (Including damage caused by the misconduct of the third party.)
 - ④ If the defect is caused by reasons other than our responsibility.
 - ⑤ If repair or modifications are carried out by anyone other than Kosmek, or without our approval and confirmation, it will void warranty.
 - ⑥ Others caused by natural disasters or calamities not attributable to our company.
 - ⑦ Parts or replacement expenses due to parts consumption and deterioration. (Such as rubber, plastic, seal material and some electric components.)

Damages excluding from direct result of a product defect shall be excluded from the warranty.



KOSMEK LTD.

▶ <https://www.kosmek.com/>

HEAD OFFICE 1-5, 2-chome, Murotani, Nishi-ku, Kobe-city, Hyogo, Japan 651-2241
TEL.+81-78-991-5162 FAX.+81-78-991-8787

United States of America SUBSIDIARY	KOSMEK (USA) LTD. 650 Springer Drive, Lombard, IL 60148 USA TEL. +1-630-620-7650 FAX. +1-630-620-9015
MEXICO REPRESENTATIVE OFFICE	KOSMEK USA Mexico Office Av. Santa Fe 103, Int. 59, col. Santa Fe Juriquilla, Queretaro, QRO, 76230, Mexico TEL. +52-442-851-1377
EUROPE SUBSIDIARY	KOSMEK EUROPE GmbH Schleppeplatz 2 9020 Klagenfurt am Wörthersee Austria TEL. +43-463-287587 FAX. +43-463-287587-20
CHINA SUBSIDIARY	KOSMEK (CHINA) LTD. Room601, RIVERSIDE PYRAMID No.55, Lane21, Pusan Rd, Pudong Shanghai 200125, China TEL. +86-21-54253000
INDIA BRANCH OFFICE	KOSMEK LTD. - INDIA 4A/Old No:649, Ground Floor, 4th D cross, MM Layout, Kavalbyrasandra, RT Nagar, Bangalore -560032 India TEL.+91-9880561695
THAILAND REPRESENTATIVE OFFICE	KOSMEK Thailand Representation Office 67 Soi 58, RAMA 9 Rd., Phatthanakan, Suanluang, Bangkok 10250, Thailand TEL. +66-2-300-5132 FAX. +66-2-300-5133

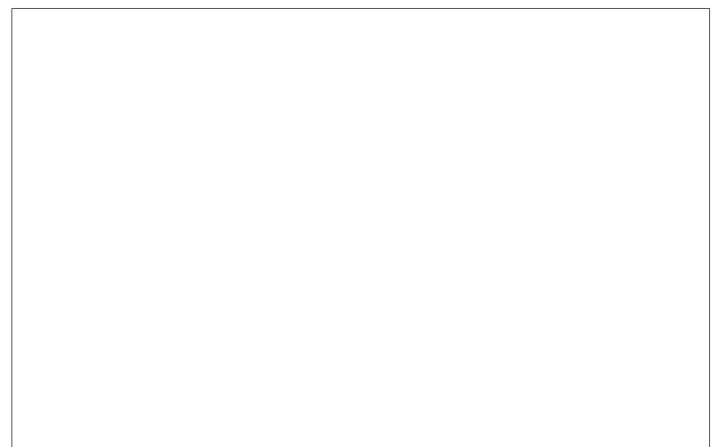

- For Further Information on Unlisted Specifications and Sizes, Please call us.
- Specifications in this Leaflet are Subject to Change without Notice.

