

New Wireless Sensing Clamp HYD. LOCK / HYD. RELEASE
Swing / Link Clamp • Linear Cylinder



Swing Clamp
model **LHM**



Link Clamp
model **LKM**



Linear Cylinder
model **LLM**

Wirelessly Detect Unclamp Position

No External Power Supply

Required for Sensor

NEW

HYD. LOCK / HYD. RELEASE

Wireless Sensing Clamp



Swing Clamp
model **LHM**



Link Clamp
model **LKM**



Linear Cylinder
model **LLM**

Wirelessly Detect Unclamp Position

No External Power Supply Required for Sensor



Individual Detection

Separate unclamp detection is possible for each clamp.



Waterproof Rating

Equivalent to **IPX7**

※ Shows the protection level of the sensor.



Response Time

0.1sec.

Quick Response[※]

※ Compared with our conventional air sensing clamps.

Minimized Number of Ports

Solution to fixture port shortage.

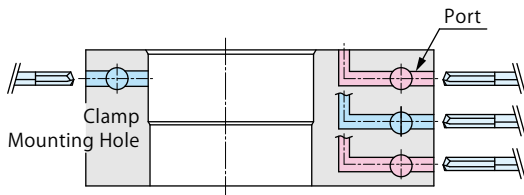

With
Wireless
Sensing

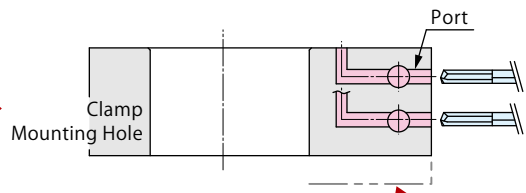

Conventional Fixture※ : Multiple Ports

Hydraulic Port × 2, Air Port × 1, Vent Port × 1

※Using our conventional air sensing clamp (model LHW-J)

Air port is not required.

Hydraulic Port × 2

Enables a thinner
and lighter fixture.

Lower Design • Fixture Cost

Design & machining costs for sensing ports are not required.

※ Image compared with our conventional air sensing clamps.



With
Wireless
Sensing



Conventional※ sensing function needed design and machining costs for ports.

※ For conventional models, please see the "Changes in Sensing Clamps" .

Fixture is simplified.

Zero Air Consumption

Detect unclamp position via wireless communication.

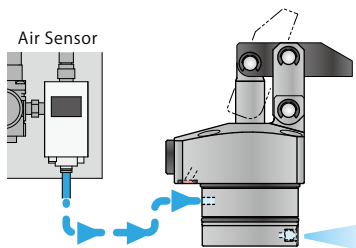

Consumes air for detection.

※ Using our conventional air sensing clamp.

With
Wireless
Sensing

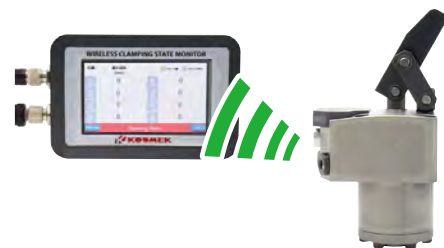

Detects wirelessly, zero air consumption.

Changes in Sensing Clamps

Model	Air Sensor Model Conventional	Air Sensing Valve Model Conventional	Wireless Sensing Model NEW
Air Consumption	High	Low	Zero
Cylinder Length	Long (High Interference)	Short	Short

Please contact us when considering the wireless sensing clamp.

Wireless Sensing Link Clamp

Hydraulic Double Action

Model LKM



Wirelessly Detect Unclamp Position.
Number of Ports is Reduced.

No External Power Supply Required for Sensor

Detects unclamp position wirelessly.

Receiver

Place : Outside Machine

Repeater

Place : Near Fixture
Inside the Processing Machine

Clamp

Place : Fixture



Action Description

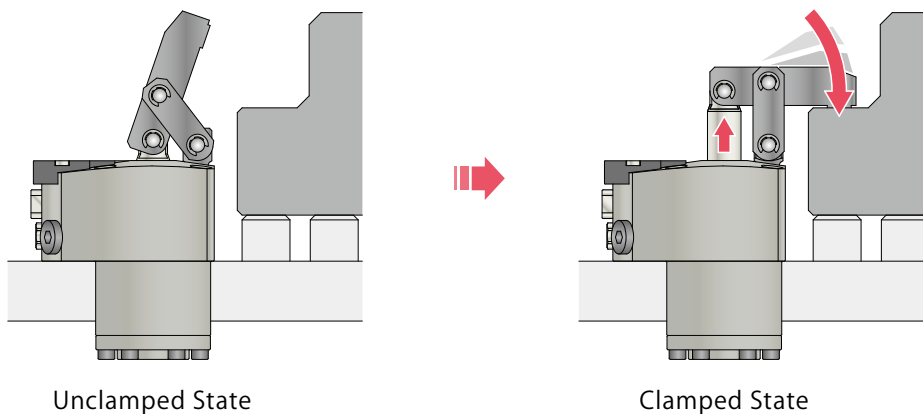

● Cross Section ※ This drawing shows Model LKM-C□-B□.

Excellent Coolant Resistance

Our exclusive dust seal is designed to protect against high pressure coolant. It also has high durability against chlorine-based coolant by using a sealing material with excellent chemical resistance.

Direct Mount Speed Control Valve

Speed control valve with air bleeding function can be directly mounted to the product. (Speed control valve is sold separately.)

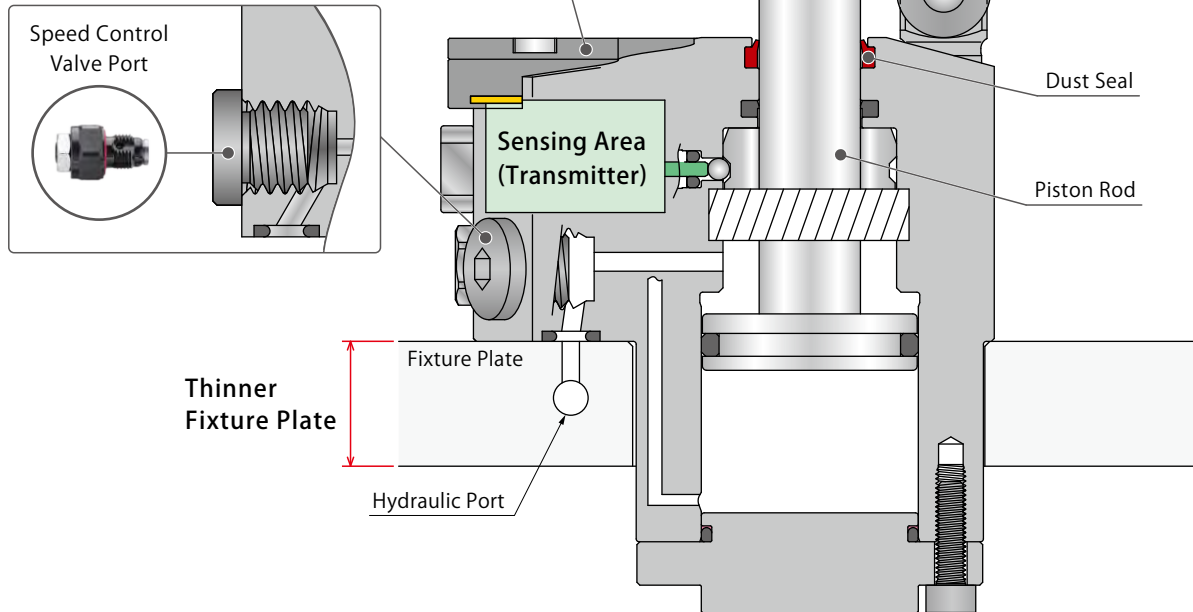

Lever in Three Directions Available

Lever positioning is available in three directions;
 L : Left, C : Center, R : Right as seen from the port side.

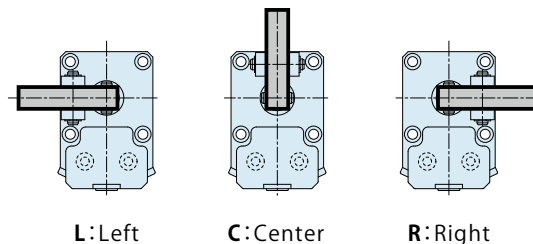

Zero Air Consumption

Detects unclamp position via wireless communication. Unlike our conventional air sensing clamps, air for action confirmation is not required.



Minimized Number of Ports • Simple Machining

Integrating ports allows for reducing the number of ports for Rotary Joint and machining for air passage of fixture plate, and simplifying the machining of mounting hole, etc.

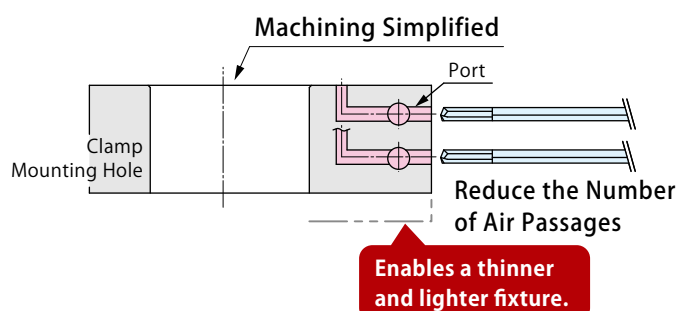

Wireless Sensing Clamp

Accessory

Common Cautions

Wireless Sensing Swing Clamp
LHM

Wireless Sensing Link Clamp
LKM

Wireless Sensing Linear Cylinder
LLM

Receiver • Repeater
YWA
YWB

● Action Description (Internal Structure) ※ The figure shows Model LKM-C□-B□.

Unclamp

Receiver ※ Refer to the website and catalog (model YWA) for further information

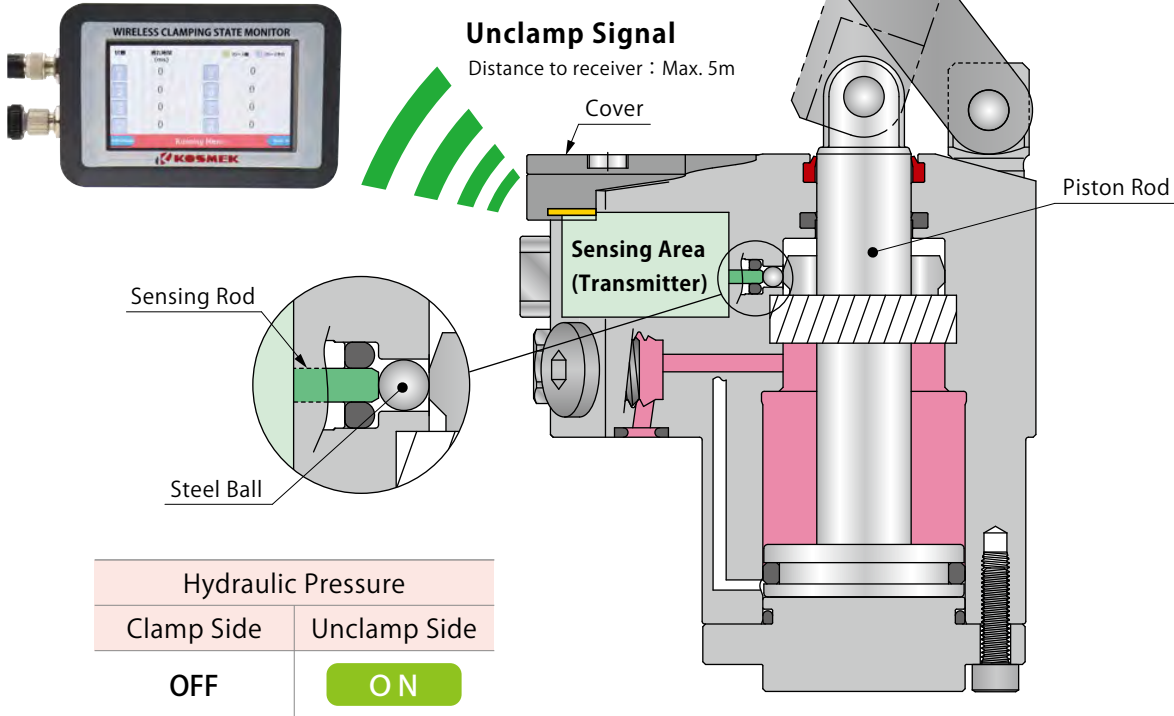

■ Unclamp (During Hydraulic Pressure Supply to Unclamping Port)

The piston rod descends.



When the piston rod pushes the sensing rod via the steel ball at the unclamp end, an unclamp signal is transmitted from the sensing area.

Connecting Multiple Wireless Sensing Clamps

When using multiple wireless sensing clamps, provide an unclamp operating time difference of 100msec (0.1 sec.) or more. Please check the operating time at the receiver, and adjust the operating time with the speed control valve if it is within 100msec. Otherwise, signals cannot be received properly due to radio interference.

Clamp

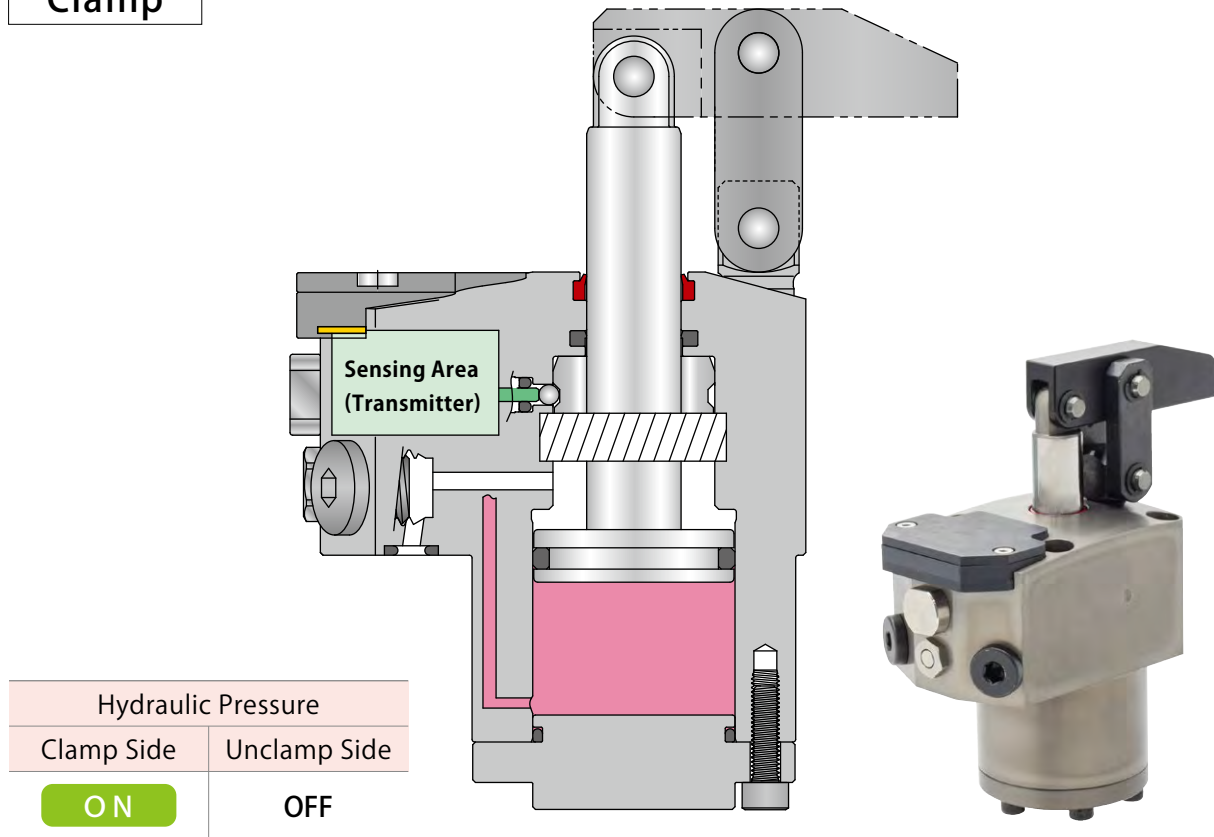

■ Clamp (During Hydraulic Pressure Supply to Clamping Port)

The piston rod ascends to clamp a workpiece.

Wireless Sensing Clamp

Accessory

Common Cautions

Wireless Sensing
Swing Clamp

LHM

Wireless Sensing
Link Clamp

LKM

Wireless Sensing
Linear Cylinder

LLM

Receiver ·
Repeater

YWA

YWB

● Model No. Indication

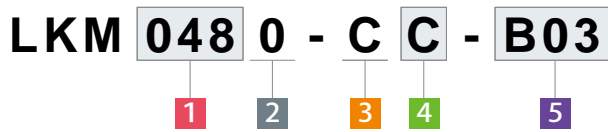

1 Body Size

- 048** : $\phi D=48\text{mm}$
- 055** : $\phi D=55\text{mm}$
- 065** : $\phi D=65\text{mm}$
- 075** : $\phi D=75\text{mm}$

※ Indicates the cylinder outer diameter (ϕD).

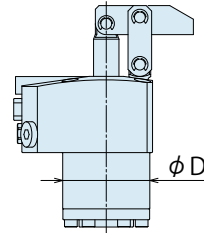

2 Design No.

- 0** : Revision Number

3 Piping Method

- C** : Gasket Option (With G Thread Plug)

※ Speed control valve (BZL) is sold separately. Please refer to P. 55.

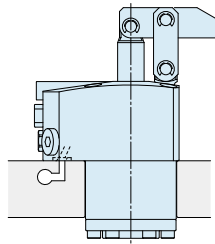

With G Thread Plug
Able to attach speed control valve

4 Lever Direction

- L** : Left
- C** : Center
- R** : Right

※ The images show the lever direction when the piping port is placed in front of you.

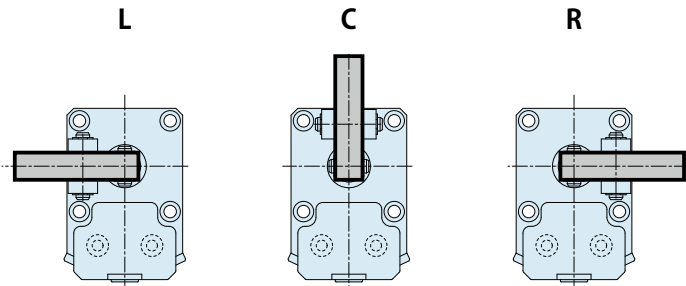

5 Available Country : Frequency

- B01** : Japan
- B02** : Europe, China
- B03** : United States

※ There are restrictions on countries where the product can be used according to radio regulations. Please follow the regulatory requirements of each country.

Specifications

Model No.		LKM0480-C□-B□	LKM0550-C□-B□	LKM0650-C□-B□	LKM0750-C□-B□
Cylinder Area for Clamping	cm ²	7.07	9.62	15.9	23.8
Cylinder Inner Diameter ※1	mm	30	35	45	55
Rod Diameter ※1	mm	14	16	20	22
Clamping Force ※2 (Calculation Formula)	kN	$F = \frac{11.76 \times P}{L - 18.5}$	$F = \frac{18.18 \times P}{L - 21}$	$F = \frac{35.06 \times P}{L - 24.5}$	$F = \frac{64.14 \times P}{L - 30}$
Full Stroke	mm	23.5	26	29.5	35
Clamp Stroke	mm	20.5	23	26.5	32
Extra Stroke	mm	3	3	3	3
Max. Operating Pressure	MPa	7			
Min. Operating Pressure ※3	MPa	1.0			
Withstanding Pressure	MPa	10.5			
Operating Temperature	°C	0 ~ 70 (Sensing Area: ~ 60°C)			
Usable Fluid		General Hydraulic Oil Equivalent to ISO-VG-32			
Wireless Sensing (Unclamp Confirmation)	Frequency	<div style="border: 1px dashed black; padding: 2px;"> 5 When selecting B01 : 920MHz Band 5 When selecting B02 : 868MHz Band 5 When selecting B03 : 902MHz Band </div>			
	Distance to Receiver	Max. 5m ※4			
	Sensing Position	ON from 1.5±0.5 mm before the unclamp end stroke.			
	Waterproof Rating	Equivalent to IPX7 (When the cover of the sensing area is completely closed.)			

Notes : ※1. Clamping force cannot be calculated from the cylinder inner diameter and rod diameter.

Please refer to the clamping force calculation formula and the clamping force curve.

※2. F : Clamping Force (kN), P : Supply Hydraulic Pressure (MPa), L : Distance between the piston center and the clamping point (mm).

※3. Minimum pressure to operate the clamp without load.

※4. The maximum distance when there is no obstruction. Check the radio wave strength displayed on the receiver and consider the location of the repeater. (Recommended Threshold Value: -85dBm)

1. Please refer to the external dimensions for cylinder capacity and product weight.

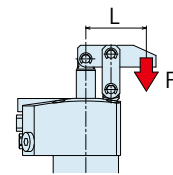

Wireless Sensing Clamp

Accessory

Common Cautions

Wireless Sensing Swing Clamp
LHM

Wireless Sensing Link Clamp
LKM

Wireless Sensing Linear Cylinder
LLM

Receiver Repeater
YWA
YWB

Clamping Force Curve

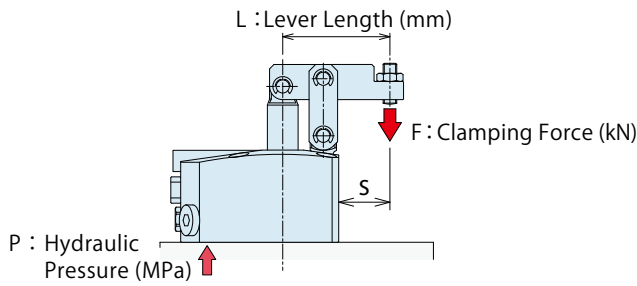

Applicable Model

LKM **0 - C** **L C R** **B01 B02 B03**

1 Body Size

(Ex.) In case of LKM0480 :

When supply hydraulic pressure P is 5.0MPa and lever length L is 42mm, clamping force becomes about 2.6kN.

Notes :

1. Tables and graphs show the relationship between the clamping force (kN) and supply hydraulic pressure (MPa).
2. Cylinder force (when L=0) cannot be calculated from the formula of clamping force.
3. Clamping force in the non-usable range may cause damage and fluid leakage.

※1. F : Clamping Force (kN), P : Supply Hydraulic Pressure (MPa), L : Lever Length (mm).

LKM0480-C□-B□										
Clamping Force Calculation Formula ※1 (kN) $F = (11.76 \times P) / (L - 18.5)$										
Hydraulic Pressure (MPa)	Cylinder Force (kN)	Clamping Force (kN) Non-Usable Range (■)								Min. Lever Length (L) (mm)
		L=30	L=35	L=42	L=50	L=60	L=80	L=100	L=120	
7	5.0			3.6	2.7	2.0	1.4	1.1	0.9	42
6.5	4.6			3.3	2.5	1.9	1.3	1.0	0.8	39
6	4.3			3.1	2.3	1.8	1.2	0.9	0.7	36
5.5	3.9		4.0	2.8	2.1	1.6	1.1	0.8	0.7	34
5	3.6		3.6	2.6	1.9	1.5	1.0	0.8	0.6	32
4.5	3.2	4.7	3.3	2.3	1.7	1.3	0.9	0.7	0.6	30
4	2.9	4.1	2.9	2.1	1.5	1.2	0.8	0.6	0.5	28
3.5	2.5	3.6	2.5	1.8	1.4	1.0	0.7	0.6	0.5	26
3	2.2	3.1	2.2	1.6	1.2	0.9	0.6	0.5	0.4	26
2.5	1.8	2.6	1.8	1.3	1.0	0.8	0.5	0.4	0.3	26
2	1.5	2.1	1.5	1.1	0.8	0.6	0.4	0.3	0.3	26
1.5	1.1	1.6	1.1	0.8	0.6	0.5	0.3	0.3	0.2	26
1	0.8	1.1	0.8	0.6	0.4	0.3	0.2	0.2	0.2	26
Max. Operating Pressure (MPa)	4.8	5.9	7.0	7.0	7.0	7.0	7.0	7.0	7.0	

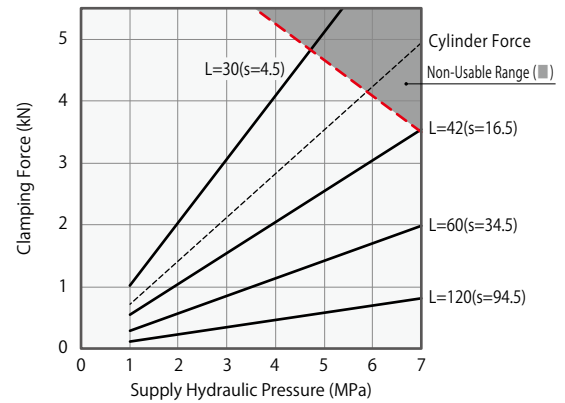

LKM0480-C□-B□										
Clamping Force Calculation Formula ※1 (kN) $F = (18.18 \times P) / (L - 21)$										
Hydraulic Pressure (MPa)	Cylinder Force (kN)	Clamping Force (kN) Non-Usable Range (■)								Min. Lever Length (L) (mm)
		L=35	L=40	L=50	L=60	L=70	L=80	L=100	L=120	
7	6.8			4.4	3.3	2.6	2.2	1.7	1.3	50
6.5	6.3			4.1	3.1	2.5	2.1	1.5	1.2	46
6	5.8			3.8	2.8	2.3	1.9	1.4	1.2	43
5.5	5.3		5.3	3.5	2.6	2.1	1.7	1.3	1.1	39
5	4.9		4.8	3.2	2.4	1.9	1.6	1.2	1.0	37
4.5	4.4	5.9	4.4	2.9	2.1	1.7	1.4	1.1	0.9	34
4	3.9	5.2	3.9	2.6	1.9	1.5	1.3	1.0	0.8	32
3.5	3.4	4.6	3.4	2.2	1.7	1.3	1.1	0.9	0.7	30
3	2.9	3.9	2.9	1.9	1.4	1.2	1.0	0.7	0.6	30
2.5	2.5	3.3	2.4	1.6	1.2	1.0	0.8	0.6	0.5	30
2	2.0	2.6	2.0	1.3	1.0	0.8	0.7	0.5	0.4	30
1.5	1.5	2.0	1.5	1.0	0.7	0.6	0.5	0.4	0.3	30
1	1.0	1.3	1.0	0.7	0.5	0.4	0.4	0.3	0.2	30
Max. Operating Pressure (MPa)	4.8	5.7	7.0	7.0	7.0	7.0	7.0	7.0	7.0	

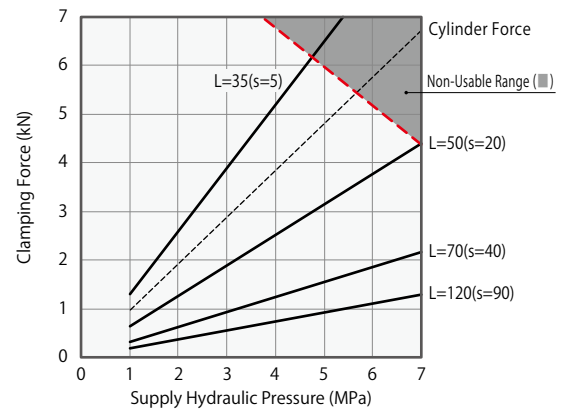

Wireless Sensing Clamp

Accessory

Common Cautions

Wireless Sensing Swing Clamp
LHM

Wireless Sensing Link Clamp
LKM

Wireless Sensing Linear Cylinder
LLM

Receiver Repeater
YWA
YWB

LKM0650-C□-B□

Clamping Force Calculation Formula ^{※1} (kN) $F = (35.06 \times P) / (L - 24.5)$

Hydraulic Pressure (MPa)	Cylinder Force (kN)	Clamping Force (kN)								Non-Usable Range (mm)	Min. Lever Length (L) (mm)
		L=40	L=50	L=56.5	L=80	L=100	L=120	L=140	L=160		
7	11.2			7.7	4.5	3.3	2.6	2.2	1.9	56.5	
6.5	10.4			7.2	4.2	3.1	2.4	2.0	1.7	52	
6	9.6		8.3	6.6	3.8	2.8	2.3	1.9	1.6	48	
5.5	8.8		7.6	6.1	3.5	2.6	2.1	1.7	1.5	45	
5	8.0		6.9	5.5	3.2	2.4	1.9	1.6	1.3	42	
4.5	7.2	10.2	6.2	5.0	2.9	2.1	1.7	1.4	1.2	39	
4	6.4	9.1	5.5	4.4	2.6	1.9	1.5	1.3	1.1	37	
3.5	5.6	8.0	4.9	3.9	2.3	1.7	1.3	1.1	1.0	35	
3	4.8	6.8	4.2	3.3	1.9	1.4	1.2	1.0	0.8	35	
2.5	4.0	5.7	3.5	2.8	1.6	1.2	1.0	0.8	0.7	35	
2	3.2	4.6	2.8	2.2	1.3	1.0	0.8	0.7	0.6	35	
1.5	2.4	3.4	2.1	1.7	1.0	0.7	0.6	0.5	0.4	35	
1	1.6	2.3	1.4	1.1	0.7	0.5	0.4	0.4	0.3	35	
Max. Operating Pressure (MPa)	4.8	6.3	7.0	7.0	7.0	7.0	7.0	7.0	7.0		

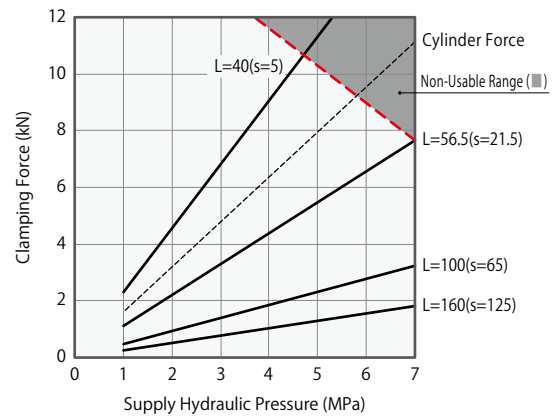

LKM0750-C□-B□

Clamping Force Calculation Formula ^{※1} (kN) $F = (64.14 \times P) / (L - 30)$

Hydraulic Pressure (MPa)	Cylinder Force (kN)	Clamping Force (kN)								Non-Usable Range (mm)	Min. Lever Length (L) (mm)
		L=50	L=60	L=67.5	L=80	L=100	L=120	L=140	L=160		
7	16.7			12.0	9.0	6.5	5.0	4.1	3.5	67.5	
6.5	15.5			11.2	8.4	6.0	4.7	3.8	3.3	63	
6	14.3		12.9	10.3	7.7	5.5	4.3	3.5	3.0	58	
5.5	13.1		11.8	9.5	7.1	5.1	4.0	3.3	2.8	54	
5	11.9	16.1	10.7	8.6	6.5	4.6	3.6	3.0	2.5	51	
4.5	10.7	14.5	9.7	7.7	5.8	4.2	3.3	2.7	2.3	48	
4	9.6	12.9	8.6	6.9	5.2	3.7	2.9	2.4	2.0	45	
3.5	8.4	11.3	7.5	6.0	4.5	3.3	2.5	2.1	1.8	43	
3	7.2	9.7	6.5	5.2	3.9	2.8	2.2	1.8	1.5	43	
2.5	6.0	8.1	5.4	4.3	3.3	2.3	1.8	1.5	1.3	43	
2	4.8	6.5	4.3	3.5	2.6	1.9	1.5	1.2	1.0	43	
1.5	3.6	4.9	3.3	2.6	2.0	1.4	1.1	0.9	0.8	43	
1	2.4	3.3	2.2	1.8	1.3	1.0	0.8	0.6	0.5	43	
Max. Operating Pressure (MPa)	5.0	6.3	7.0	7.0	7.0	7.0	7.0	7.0	7.0		

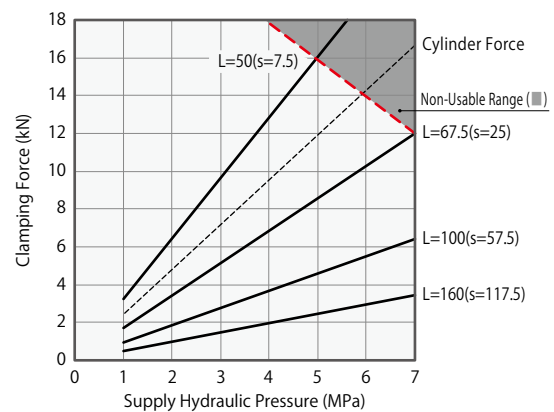

Allowable Offset Graph

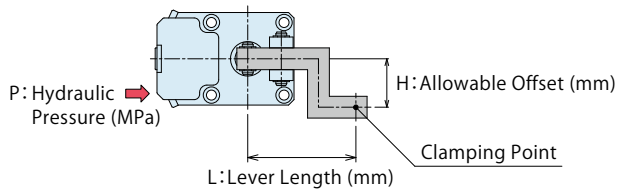

Applicable Model
LKM 0 - C L C R - B01 B02 B03
1 Body Size

(Ex.) In case of LKM0480 :

When supply hydraulic pressure P is 5.0MPa and lever length L is 80mm, allowable offset becomes about 10mm.

Notes :

1. Tables and graphs show the relationship between the lever length and the allowable offset according to the supply hydraulic pressure.
2. Using the lever beyond allowable offset may cause deformation, seizure and fluid leakage etc.
3. The tables and graphs are only for reference. The design should be carried out with allowance fully taken into consideration.

LKM0480-C□-B□									
Hydraulic Pressure (MPa)	Allowable Offset H (mm) Non-Usable Range (■)								
	Lever Length L (mm)								
	L=30	L=35	L=42	L=50	L=60	L=80	L=100	L=120	
7	■	■	■	3	4	6	7	9	
6.5	■	■	2	3	4	6	9	11	
6	■	■	3	4	5	8	10	12	
5.5	■	2	3	5	6	9	12	15	
5	■	3	4	5	7	10	14	17	
4.5	■	3	5	6	8	12	16	20	
4	3	4	6	7	10	15	19	24	
3.5	3	5	7	9	12	18	23	29	
3	4	6	8	11	15	22	29	36	
2.5	5	7	10	14	18	27	36	45	
2	7	10	14	18	24	36	47	59	
1.5	9	13	19	25	33	50	60	60	
1	14	21	30	40	52	60	60	60	

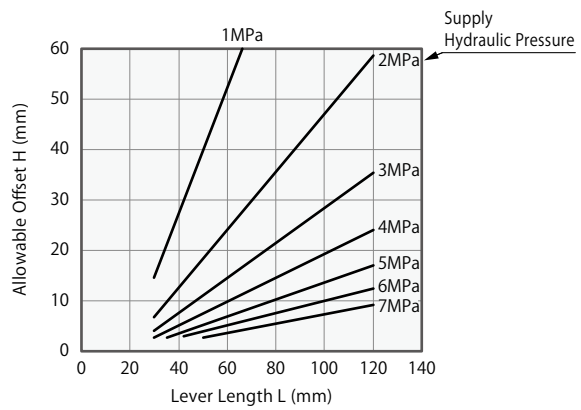

LKM0550-C□-B□									
Hydraulic Pressure (MPa)	Allowable Offset H (mm) Non-Usable Range (■)								
	Lever Length L (mm)								
	L=35	L=40	L=50	L=60	L=70	L=80	L=100	L=120	
7	■	■	■	5	6	7	9	12	
6.5	■	■	4	5	7	8	11	14	
6	■	■	5	6	8	10	13	16	
5.5	■	■	5	7	9	11	15	19	
5	■	4	6	9	11	13	17	22	
4.5	■	5	8	10	13	15	21	26	
4	4	6	9	12	15	18	25	31	
3.5	5	7	11	15	18	22	30	37	
3	6	9	13	18	23	27	36	46	
2.5	8	11	17	23	28	34	46	57	
2	11	14	22	30	37	45	60	75	
1.5	15	20	31	41	52	62	80	80	
1	23	31	48	65	80	80	80	80	

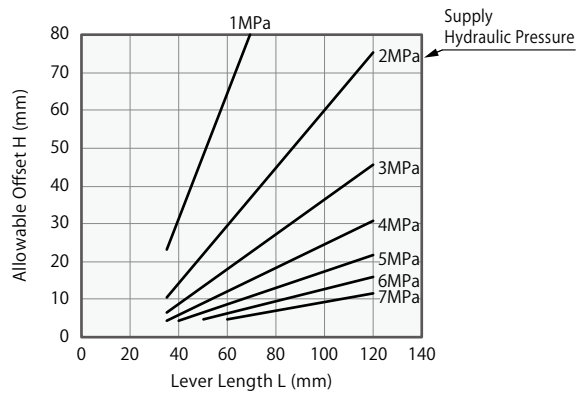

Wireless Sensing Clamp

Accessory

Common Cautions

Wireless Sensing Swing Clamp
LHM

Wireless Sensing Link Clamp
LKM

Wireless Sensing Linear Cylinder
LLM

Receiver Repeater
YWA
YWB

LKM0650-C□-B□

Hydraulic Pressure (MPa)	Allowable Offset H (mm) Non-Usable Range (■)							
	Lever Length L (mm)							
	L=40	L=50	L=56.5	L=80	L=100	L=120	L=140	L=160
7	■	■	■	5	7	9	11	13
6.5	■	■	4	6	9	11	13	15
6	■	■	4	7	10	13	15	18
5.5	■	4	5	9	12	15	18	21
5	■	5	6	10	14	17	21	25
4.5	3	5	7	12	16	20	25	29
4	4	7	8	14	19	24	30	35
3.5	5	8	10	17	23	29	36	42
3	6	10	12	21	29	36	44	51
2.5	7	12	15	26	36	46	55	65
2	10	16	20	35	47	60	72	85
1.5	13	22	28	48	66	83	95	95
1	21	35	44	76	95	95	95	95

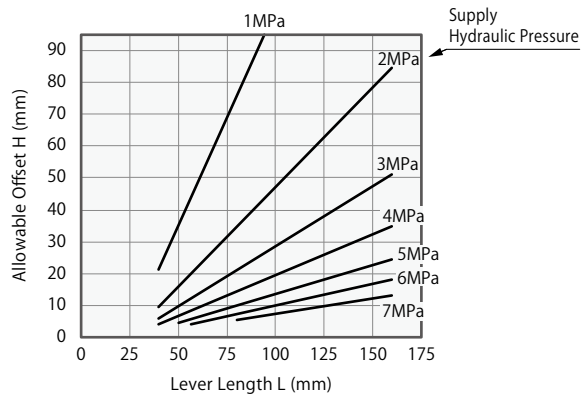

LKM0750-C□-B□

Hydraulic Pressure (MPa)	Allowable Offset H (mm) Non-Usable Range (■)							
	Lever Length L (mm)							
	L=50	L=60	L=67.5	L=80	L=100	L=120	L=140	L=160
7	■	■	■	5	7	9	11	13
6.5	■	■	5	6	8	11	13	16
6	■	■	4	5	7	10	13	15
5.5	■	■	4	5	7	10	13	18
5	4	6	7	10	13	17	21	25
4.5	5	7	9	11	16	20	25	30
4	5	8	10	14	19	24	30	35
3.5	7	10	12	16	23	29	36	42
3	8	12	15	20	28	36	44	52
2.5	10	15	19	25	35	45	56	66
2	13	20	25	33	46	60	73	86
1.5	18	28	35	46	65	83	101	110
1	29	43	54	72	101	110	110	110

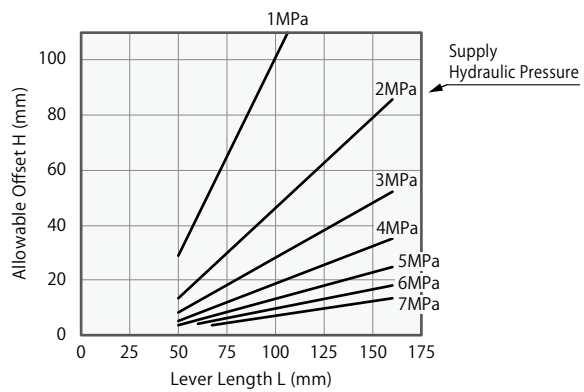

External Dimensions

C : Gasket Option (With G Thread Plug)

※ The drawing shows the clamped state of LKM-CC-B□.

LKM0480-C□-B□ / LKM0550-C□-B□

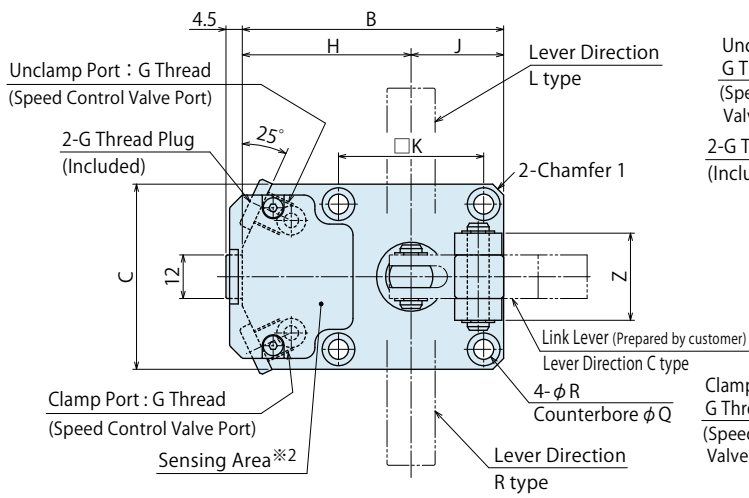

LKM0650-C□-B□ / LKM0750-C□-B□

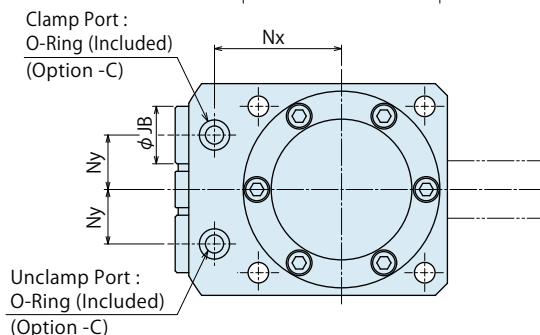
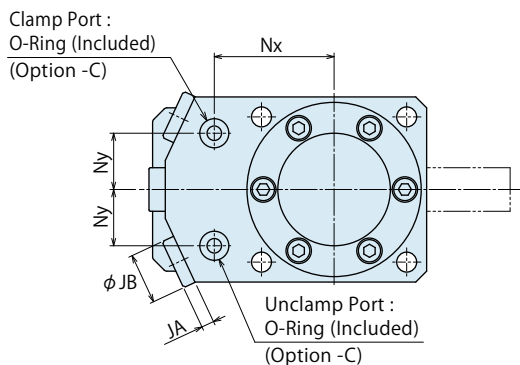
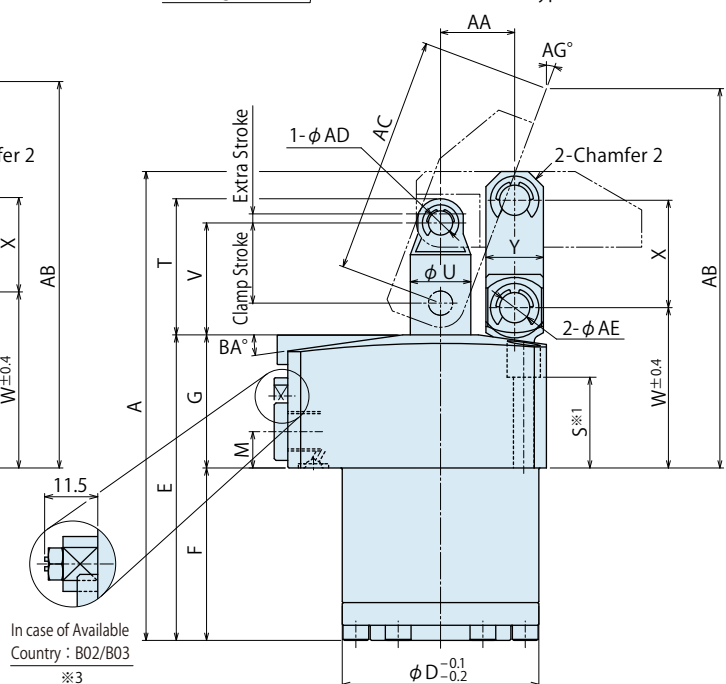
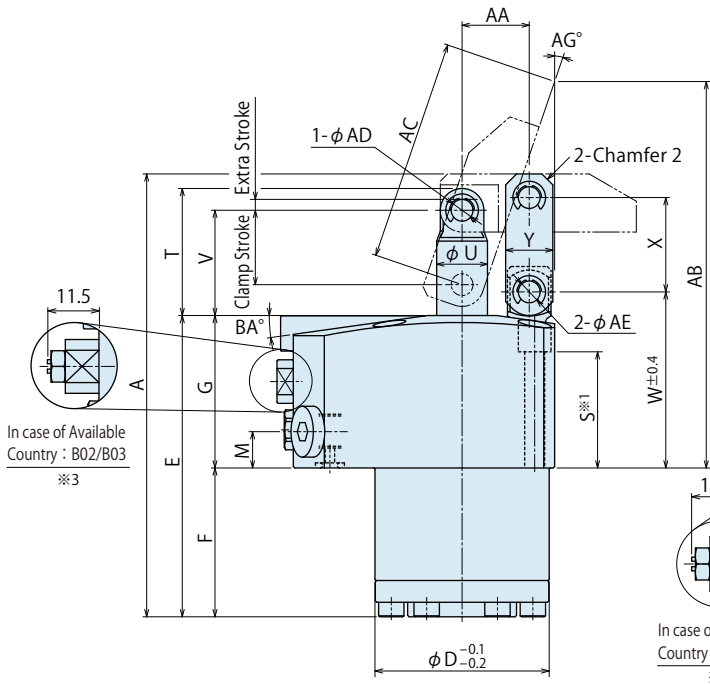
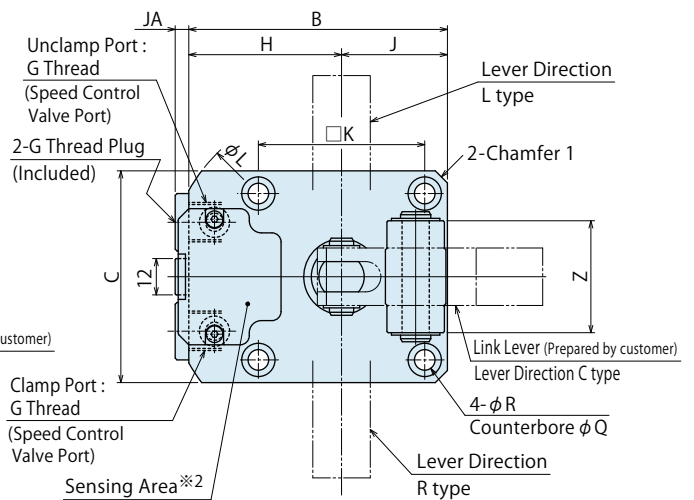

Notes:

- ※1. Mounting bolts are not provided. Please prepare them according to the mounting height referring to dimension 'S'.
- ※2. Do not cover the top surface of the sensing area with metal objects (chips, sludge, etc.). It may obstruct radio wave transmission.
- ※3. Please refer to P.33 "Notes for Design 2) Radio Regulations" .
 1. Please use the provided pin (equivalent to φADf6, φAEf6, HRC60) as mounting pin for lever.
 2. Speed control valve is sold separately. Please refer to P.55. It is necessary to provide an unclamp operation time difference of at least 100 msec. For adjusting the unclamp operation, please use a speed control valve.

Model No. Indication

(Format Example : LKM0550-CC-B02, LKM0750-CR-B03)

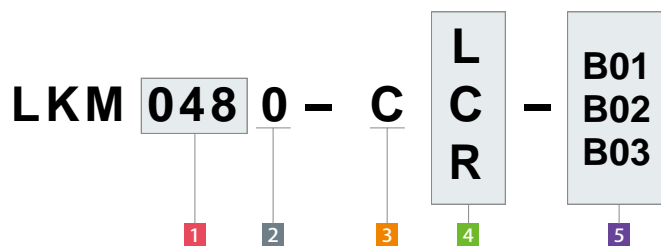

1 Body Size

2 Design No.

3 Piping Method

4 Lever Direction

5 Available Country : Frequency

Machining Dimensions of Mounting Area

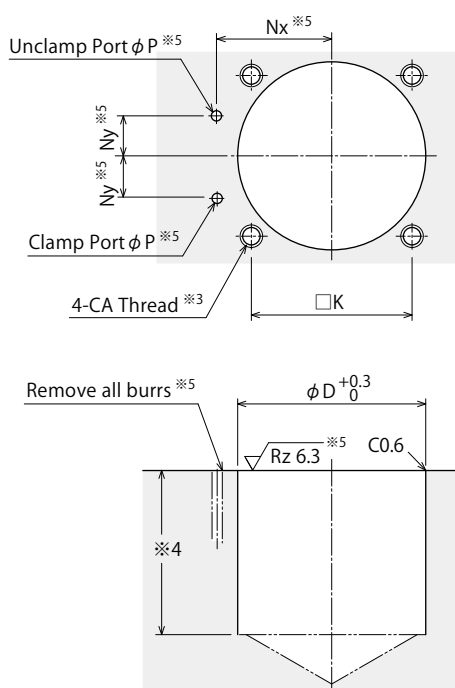

Notes :

- ※3. CA tapping depth of the mounting bolt should be decided according to the mounting height referring to dimension 'S'.
- ※4. The depth of the body mounting hole ϕD should be decided according to the mounting height referring to dimension 'F'.
- ※5. The machining dimension is for -C: Gasket Option.

External Dimensions and Machining Dimensions for Mounting

(mm)

Model No.	LKM0480-C□-B□	LKM0550-C□-B□	LKM0650-C□-B□	LKM0750-C□-B□	
Full Stroke	23.5	26	29.5	35	
Clamp Stroke	20.5	23	26.5	32	
Extra Stroke	3	3	3	3	
A	122	130.5	155	178.5	
B	72	78	85.5	95.8	
C	51	60	70	85	
D	48	55	65	75	
E	83	85	101	111.5	
F	41	43	57	67.5	
G	42	42	44	44	
H	46.5	48	50.5	53.3	
J	25.5	30	35	42.5	
K	40	47	55	63	
L	-	-	116	122	
M	10	10	12	12	
Nx	33	34.5	42	45	
Ny	15.5	16	18	19	
P	3	3	5	5	
Q	9	10.5	11	14	
R	5.5	6.8	6.8	9	
S	32	30	30	27	
T	35	37.5	45	55	
U	14	16	20	22	
V	29	31.5	37	45	
W	48.5	49.5	53	55	
X	26	30	35.5	43.5	
Y	13	16	19	25	
Z	24	28	37	40	
Chamfer 1	C3	C3	C4	C10	
Chamfer 2	C3	C3	C5	C5	
AA	18.5	21	24.5	30	
AB	106.5	115.9	125.4	137.8	
AC	61.2	71.7	78.7	90.8	
AD	6	6	8	10	
AE	6	8	10	12	
AG	18.9	19.9	20.5	21.4	
BA	8	8	8	11	
CA	M5×0.8	M6	M6	M8	
JA	3.5	3.5	4.5	4.5	
JB	14	14	19	19	
Clamp Port : G Thread	G1/8	G1/8	G1/4	G1/4	
Unclamp Port : G Thread	G1/8	G1/8	G1/4	G1/4	
O-ring	OR NBR-90 P5-N	OR NBR-90 P5-N	OR NBR-90 P7-N	OR NBR-90 P7-N	
Cylinder	Clamp	16.6	25	46.9	83.2
Capacity cm ³	Unclamp	13	19.8	37.7	69.8
Weight ^{※6}	kg	1.5	1.9	3.1	4.3

Note : ※6. It shows the weight of single clamp without the link lever.

Wireless Sensing Clamp

Accessory

Common Cautions

Wireless Sensing Swing Clamp
LHM

Wireless Sensing Link Clamp
LKM

Wireless Sensing Linear Cylinder
LLM

Receiver · Repeater
YWA
YWB

Link Lever Design Dimensions

※ Reference for designing link lever.

Corresponding Model No. **LKM** **0 - C** L
C
R

1 Body Size

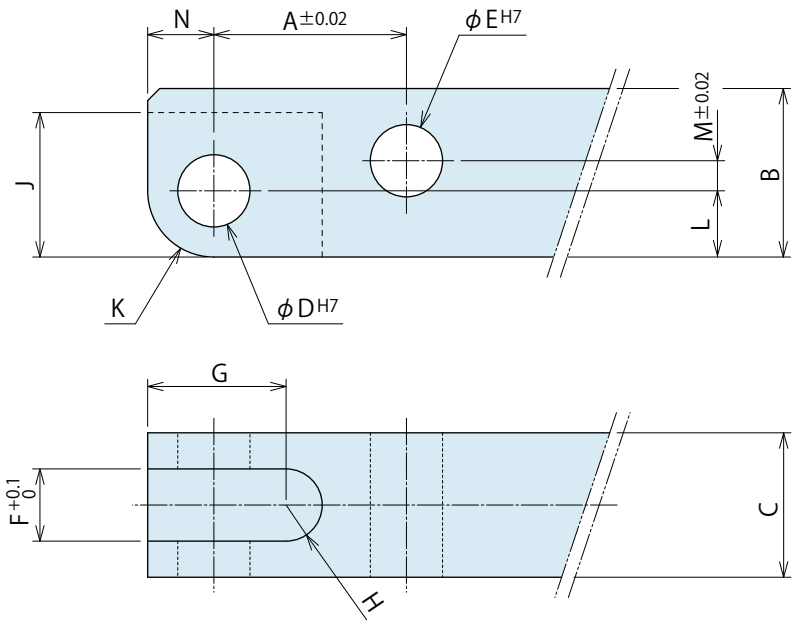

Link Lever Design Dimension List

(mm)

Corresponding Model No.	LKM0480 -C□-B□	LKM0550 -C□-B□	LKM0650 -C□-B□	LKM0750 -C□-B□
A	18.5	21	24.5	30
B	16	20	25	32
C	$12_{-0.3}^0$	$16_{-0.3}^0$	$19_{-0.3}^0$	$22_{-0.3}^0$
D	$6_{0}^{+0.012}$	$6_{0}^{+0.012}$	$8_{0}^{+0.015}$	$10_{0}^{+0.015}$
E	$6_{0}^{+0.012}$	$8_{0}^{+0.015}$	$10_{0}^{+0.015}$	$12_{0}^{+0.018}$
F	6	8	10	11
G	13	12.5	16	20
H	R3	R4	R5	R5.5
J	13	13	17.5	22
K	R6	R6	R8	R10
L	6	6	8	10
M	3.5	6	7.5	9.5
N	6	6	8	10

Notes:

1. Link lever should be designed with its length according to performance curve.
2. If the link lever is not in accordance with the dimension shown above, its performance may be degraded, and damage can occur.
3. Please use the provided pin (equivalent to $\phi ADf6$, $\phi AEF6$, HRC60) as the lever mounting pin.
(Refer to external dimensions of the clamp body for the dimensions of ϕAD , ϕAE .)

● Accessory : Material Link Lever

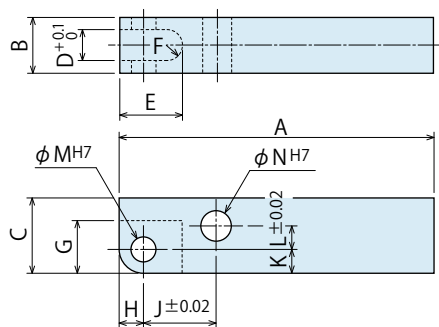

Model No. Indication

LZK 048 0 - L

 Size
(Refer to the table.)

 Design No.
(Revision Number)

(mm)

Model No.	LZK0480-L	LZK0550-L	LZK0650-L	LZK0750-L
Corresponding Model No.	LKM0480-C□-B□	LKM0550-C□-B□	LKM0650-C□-B□	LKM0750-C□-B□
A	85	90	105	110
B	12 ⁰ _{-0.3}	16 ⁰ _{-0.3}	19 ⁰ _{-0.3}	22 ⁰ _{-0.3}
C	16	20	25	32
D	6	8	10	11
E	16	16.5	21	25.5
F	R3	R4	R5	R5.5
G	13	13	17.5	22
H	6	6	8	10
J	18.5	21	24.5	30
K	6	6	8	10
L	3.5	6	7.5	9.5
M	6 ^{+0.012} ₀	6 ^{+0.012} ₀	8 ^{+0.015} ₀	10 ^{+0.015} ₀
N	6 ^{+0.012} ₀	8 ^{+0.015} ₀	10 ^{+0.015} ₀	12 ^{+0.018} ₀

Notes :

1. Material : S45C Surface Finishing : Alkaline Blackening
2. If necessary, the front end should be additionally machined and finished.
3. Please use the provided pin (equivalent to ϕ ADf6, ϕ AEf6, HRC60) as the lever mounting pin.

Wireless Sensing Clamp

Accessory

Common Cautions

 Wireless Sensing
 Swing Clamp
 LHM

 Wireless Sensing
 Link Clamp
 LKM

 Wireless Sensing
 Linear Cylinder
 LLM

 Receiver ·
 Repeater
 YWA
 YWB

Cautions

Notes for Design

- 1) Check Specifications
 - Please use each product according to the specifications.
- 2) Radio Regulations
 - There are restrictions on countries where the product can be used according to radio regulations. Please follow the regulatory requirements of each country. (Ex.) LKM□-C□-B03 can be used in United States.

Regarding LKM□-C□-B02/B03

- At shipment, the signal transmission is in a disabled state, with the function stop nut attached. When enabling signal transmission, please remove the "function stop nut" before use.

Signal Transmission Function OFF Setting

- If it is absolutely necessary to operate this product in a country other than the available country, please disable the signal transmission function using the following settings.
By attaching the "function stop nut" and fixing the sensing rod to prevent movement, the signal transmission function can be stopped.

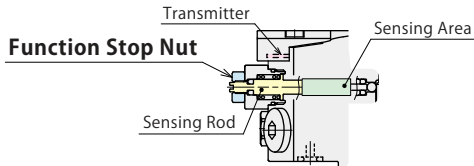

※ 5 Available Country : B01 does not support this function. (Please contact us separately if necessary.)

- 3) Notes for Circuit Design
 - Please read "Notes on Hydraulic Cylinder Speed Control Unit" for proper hydraulic circuit design. Improper circuit design may lead to malfunctions and damages. (Refer to P.60)
 - Ensure there is no possibility of supplying hydraulic pressure to the clamp port and the unclamp port simultaneously.
- 4) Notes for Link Lever Design
 - Make sure no force is applied to the piston rod except from the axial direction. The usage like the one shown in the drawing below will apply a large bending stress to the piston rod and must be avoided.

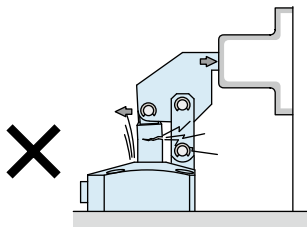

- If offset load is applied on the link part, use it within the allowable range of "Allowable Offset Graph".
- 5) Protect the exposed area of the piston rod and link plate when using on a welding fixture.
 - If spatter attaches to the sliding surface it could lead to malfunction and fluid leakage.

- 6) When clamping on a sloped surface of the workpiece
 - Make sure the clamping surface and the mounting surface of the clamp are parallel.

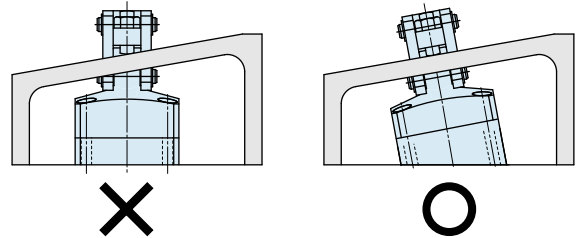

- 7) When using in a dry environment.
 - The link pin can be dried out. Grease it periodically or use a special pin. Contact us for the specifications for special pins.
- 8) Installation of Sequence Valve (model BZS)
 - Please contact us when the sequence valve model BZS0200 needs to be installed on LKM0650-C□-B□ or LKM0750-C□-B□. In some cases, installation may not be possible due to conditions and combinations of the products.

Notes for Usage

- 1) Do not cover the top surface of the sensing area with metal objects (chips, sludge, etc.). It may obstruct radio wave transmission. The cover is made of plastic material and should be protected from chips.

● Installation Notes

1) Check the Usable Fluid

- Please use the appropriate fluid by referring to the Hydraulic Fluid List (P.59).

2) Installation of the Product

- When mounting the clamp, use hexagonal socket bolts as multiple bolt holes for mounting (with tensile strength of 12.9) and tighten them with the torque shown in the table below. Tightening with greater torque than recommended can dent the seating surface or break the bolt.

Model No.	Mounting Bolt Size	Tightening Torque (N·m)
LKM0480-C□-B□	M5×0.8	8.0
LKM0550-C□-B□	M6×1	14
LKM0650-C□-B□	M6×1	14
LKM0750-C□-B□	M8×1.25	33

3) Installation / Removal of the Link Lever

- When inserting the link pin, do not hit the pin directly with a hammer. When using a hammer to insert the pin, always use a cover plate with a smaller diameter than the spring ring groove on the pin.

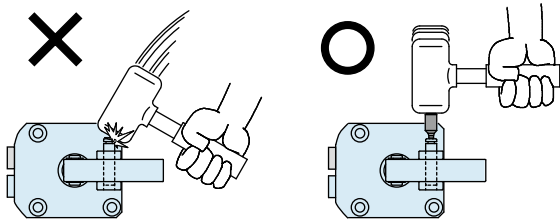

4) Speed Adjustment

- Adjust the speed so that the total operating time is at least 1 second. If the clamp operates too fast the parts will be worn out leading to premature damage and ultimately complete equipment failure.
- Please make sure to release air from the circuit before adjusting speed. It will be difficult to adjust the speed accurately with air mixed in the circuit.
- Turn the speed control valve gradually from the low-speed side (small flow) to the high-speed side (large flow) to adjust the speed.
- When using multiple wireless sensing clamps / linear cylinders, provide an operating time difference of 100msec (0.1 sec.) or more. Simultaneous operation may cause radio interference, which may result in failure to receive unclamp signals properly. For adjusting the unclamp operation, please use a speed control valve.

5) Initial Connection Settings for the Receiver

During setup, it is necessary to perform the initial connection settings between the clamp and the receiver. (For detailed instructions, please refer to the instruction manual of receiver YWA.)

6) Cautions for Repeater Installation

The maximum distance between the clamp and the receiver is 5 meters. Check the radio wave strength displayed on the receiver and consider the location of the repeater. (Recommended Threshold : -85dBm) It is recommended to install the repeater in locations such as the upper part inside the processing machine, where it is less likely to be exposed to coolant or chips.

Guidelines for Repeater Installation

- ① When the receiver cannot be installed at a height of 2 meters or more.
- ② When there is a radio wave obstruction between the clamp and the receiver.
- ③ When the clamp and the receiver are more than 3 meters apart.

Wireless Sensing Clamp

Accessory

Common Cautions

Wireless Sensing Swing Clamp
LHM

Wireless Sensing Link Clamp
LKM

Wireless Sensing Linear Cylinder
LLM

Receiver · Repeater
YWA
YWB

※ Please refer to P.59 for common cautions.

• Installation Notes • Hydraulic Fluid List • Notes on Hydraulic Cylinder Speed Control Circuit
• Notes on Handling • Maintenance/Inspection • Warranty

Speed Control Valve (For Low Pressure)

Directly Mounted to Clamps / Cylinders
 Speed Control Valve (model BZL) attaches directly to KOSMEK hydraulic clamp with piping method: type C.

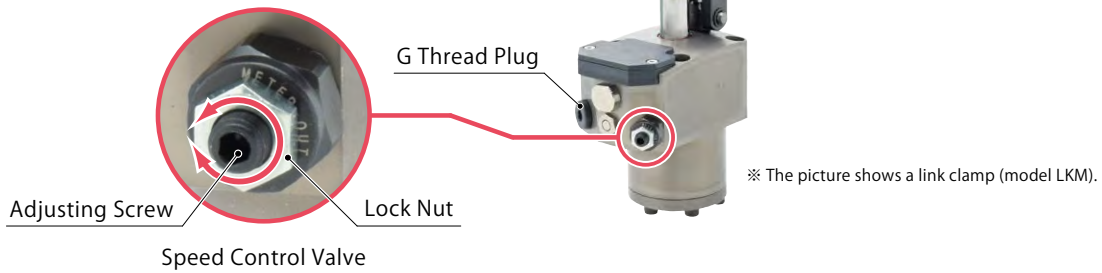

Action Description

Control the flow with a wrench. Able to change the operating speed of a clamp/cylinder individually.

Able to release the air in the circuit by loosening the Speed Control Valve.

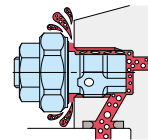
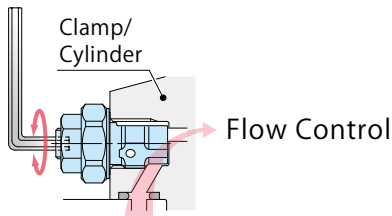

Model No. Indication (Speed Control Valve for Low Pressure)

BZL 0 10 1 - B

1 2 3

1 G Thread Size

- 10** : Thread Part G1/8A Thread
- 20** : Thread Part G1/4A Thread

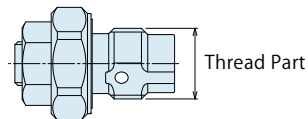

2 Design No.

- 1** : Revision Number

3 Control Method

B : Meter-out (Recommended^{※1})

A : Meter-in

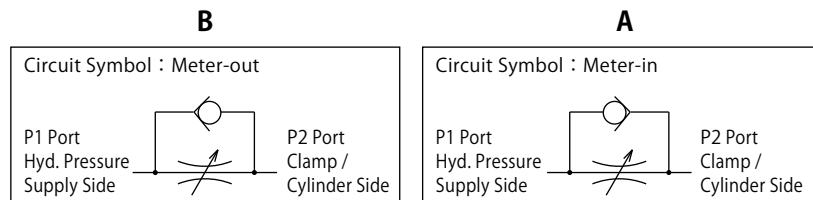

※1. Flow control circuit for double-acting clamp/cylinder should have meter-out circuits for both the clamp and unclamp sides (except model LKE/TLA/TMA). Meter-in circuits can be adversely affected by any air in the system.

Specifications

Model No.	BZL0101-B	BZL0201-B	BZL0101-A	BZL0201-A	
Max. Operating Pressure	MPa	7			
Withstanding Pressure	MPa	10.5			
Control Method	Meter-out		Meter-in		
G Thread Size	G1/8A	G1/4A	G1/8A	G1/4A	
Cracking Pressure	MPa	0.12		0.04	
Max. Passage Area	mm ²	2.6	5.0	2.6	5.0
Usable Fluid	°C	0 ~ 70			
Operating Temperature	General Hydraulic Oil Equivalent to ISO-VG-32				
Tightening Torque for Main Body	N·m	10	25	10	25
Weight	g	12	26	12	26

- Notes : 1. It must be mounted with recommended torque. Because of the structure of the metal seal, if mounting torque is insufficient, the flow control valve may not be able to adjust the flow rate.
2. Do not attach a used BZL to other clamps/cylinders.
Flow control will not be made because the bottom depth difference of G thread makes metal seal insufficient.

Applicable Products

Model No.	LHM (Double Action) Swing Clamp	LKM (Double Action) Link Clamp	LLM (Double Action) Linear Cylinder
BZL0101-B	LHM0480-C□-B□ LHM0550-C□-B□	LKM0480-C□-B□ LKM0550-C□-B□	LLM0480-C□□-B□-□ LLM0550-C□□-B□-□
BZL0101-A	(LHM0480-C□-B□) (LHM0550-C□-B□)	(LKM0480-C□-B□) (LKM0550-C□-B□)	(LLM0480-C□□-B□-□) (LLM0550-C□□-B□-□)
BZL0201-B	LHM0650-C□-B□ LHM0750-C□-B□	LKM0650-C□-B□ LKM0750-C□-B□	
BZL0201-A	(LHM0650-C□-B□) (LHM0750-C□-B□)	(LKM0650-C□-B□) (LKM0750-C□-B□)	

Flow Rate Graph < Hydraulic Fluids ISO-VG32 (25 ~ 35°C) >

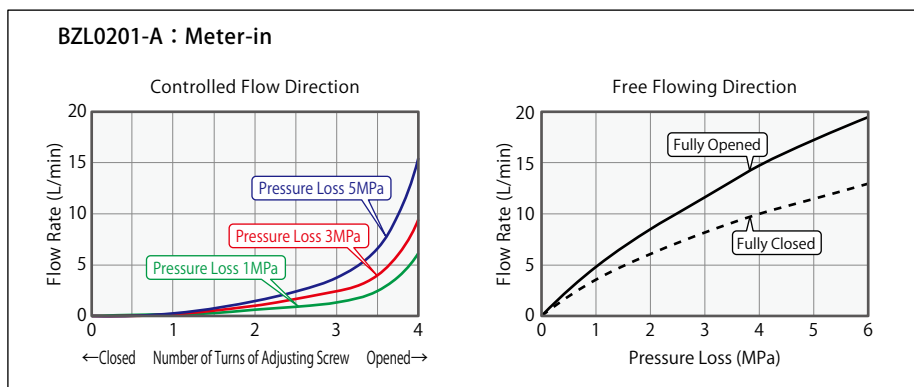
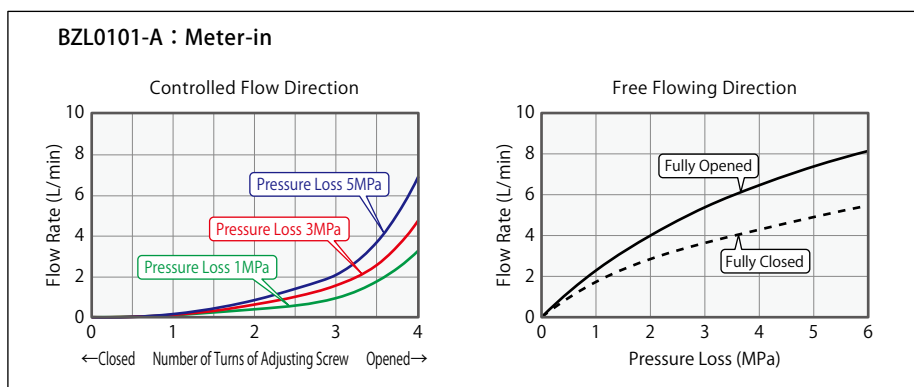
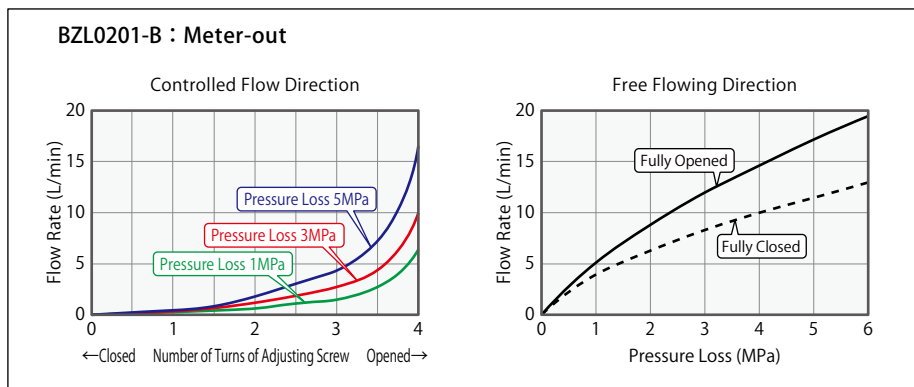
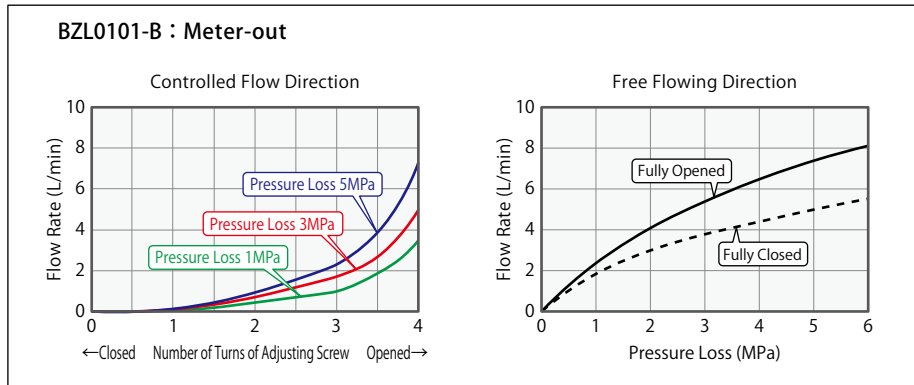

External Dimensions

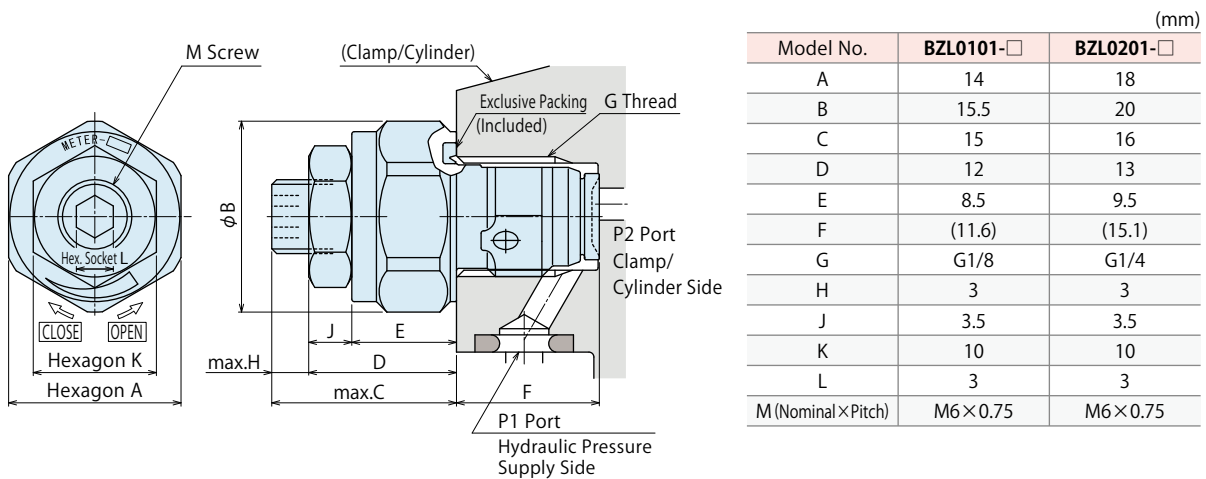

Notes

1. Please read "Notes on Hydraulic Cylinder Speed Control Unit" for proper hydraulic circuit design. Improper circuit design may lead to malfunctions and damages. (Refer to P.60)
2. It is dangerous to release the air under high pressure. It must be done under lower pressure. (For reference : the minimum operating range of the product within the circuit.)
3. Flow control circuit for double-acting clamp/cylinder should have meter-out circuits for both the clamp and unclamp sides (except model LKE/TLA/TMA). Meter-in circuits can be adversely affected by any air in the system.

● Cautions

● Installation Notes (For Hydraulic Series)

- 1) Check the Usable Fluid
 - Please use the appropriate fluid by referring to the Hydraulic Fluid List.
- 2) Procedure before Piping
 - The pipeline, piping connector and fixture circuits should be cleaned by thorough flushing.
 - The dust and cutting chips in the circuit may lead to fluid leakage and malfunction.
 - There is no filter provided with Kosmek's product except for a part of valves which prevents foreign materials and contaminants from getting into the circuit.
- 3) Applying Sealing Tape
 - Wrap with tape 1 to 2 times following the screw direction.
 - Pieces of the sealing tape can lead to oil leakage and malfunction.
 - Please implement piping construction in a clear environment to prevent anything getting in products.
- 4) Air Bleeding of the Hydraulic Circuit
 - If the hydraulic circuit has excessive air, the action time may become very long. If air enters the circuit after connecting the hydraulic port or under the condition of no air in the oil tank, please perform the following steps.
 - ① Reduce hydraulic pressure to less than 2MPa.
 - ② Loosen the cap nut of pipe fitting closest to the clamp by one full turn.
 - ③ Shake the pipeline to loosen the outlet of pipe fitting.
Hydraulic fluid mixed with air comes out.

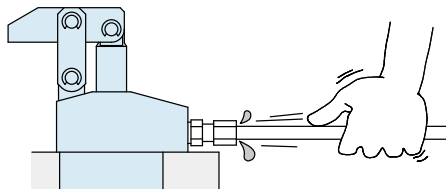

- ④ Tighten the cap nut after bleeding.
- ⑤ It is more effective to release air at the highest point inside the circuit or at the end of the circuit.
(Set an air bleeding valve at the highest point inside the circuit.)

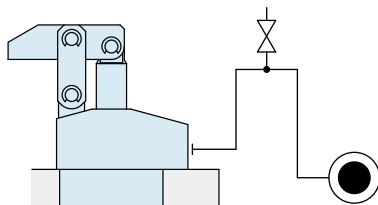

5) Checking Looseness and Retightening

- At the beginning of the machine installation, the bolt and nut may be tightened lightly. Check the looseness and re-tighten as required.

● Hydraulic Fluid List

ISO Viscosity Grade ISO-VG-32		
Maker	Anti-Wear Hydraulic Oil	Multi-Purpose Hydraulic Oil
Showa Shell Sekiyu	Tellus S2 M 32	Morlina S2 B 32
Idemitsu Kosan	Daphne Hydraulic Fluid 32	Daphne Super Multi Oil 32
JX Nippon Oil & Energy	Super Hyrando 32	Super Mulpus DX 32
Cosmo Oil	Cosmo Hydro AW32	Cosmo New Mighty Super 32
ExxonMobil	Mobil DTE 24	Mobil DTE 24 Light
Matsumura Oil	Hydol AW-32	
Castrol	Hyspin AWS 32	

Note : Please contact manufacturers when customers require products in the list above.

● Notes on Hydraulic Cylinder Speed Control Unit

Please pay attention to the cautions below. Design the hydraulic circuit for controlling the action speed of hydraulic cylinder. Improper circuit design may lead to malfunctions and damages. Please review the circuit design in advance.

● Flow Control Circuit for Single Acting Cylinder
For spring return single-acting cylinders, restricting flow during release can extremely slow down or disrupt release action. The preferred method is to control the flow during the lock action using a valve that has free-flow in the release direction. It is also preferred to provide a flow control valve at each actuator.

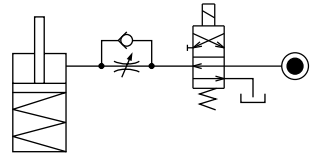

Accelerated clamping speed by excessive hydraulic flow to the cylinder may sustain damage. In this case add flow control to regulate flow. (Please add flow control to release flow if the lever weight is put on at the time of release action when using swing clamps.)

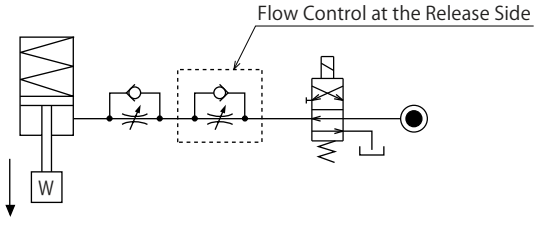

● Flow Control Circuit for Double Acting Cylinder
Flow control circuit for double-acting cylinder (except LKE/LSE/TLA/TLB/TMA/TLV/TMV/TTA) should have meter-out circuits for both the lock and release sides. Meter-in control can have adverse effect by presence of air in the system. However, in the case of controlling LKE, LSE, TLA, TLB, TMA, TLV, TMV, TTA both lock side and release side should be meter-in circuit. If meter-out circuit is used for TLA, TLB, TMA, TLV, TMV, TTA, abnormal high pressure is created, which causes oil leakage and damage.

【Meter-out Circuit】 (Except LKE/LSE/TLA/TLB/TMA/TLV/TMV/TTA)

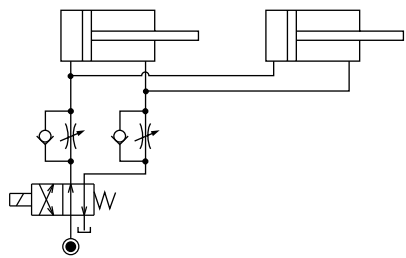

【Meter-in Circuit】 (LKE/LSE/TLA/TLB/TMA/TLV/TMV/TTA must be controlled with meter-in.)

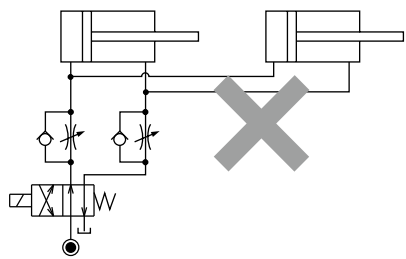

In the case of meter-out circuit, the hydraulic circuit should be designed with the following points.

- ① Single acting components should not be used in the same flow control circuit as the double acting components. The release action of the single acting cylinders may become erratic or very slow.

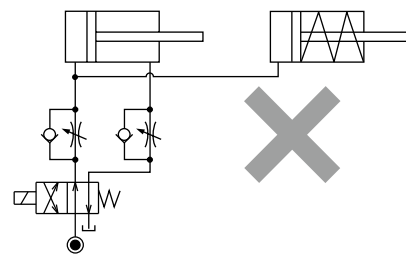

Refer to the following circuit when both the single acting cylinder and double acting cylinder are used together.

- Separate the control circuit.

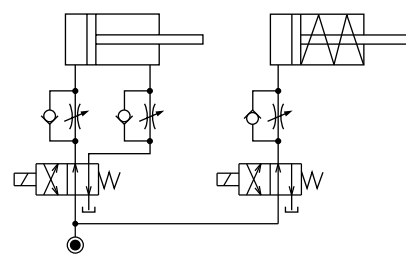

- Reduce the influence of double acting cylinder control unit. However, due to the back pressure in tank line, single action cylinder is activated after double action cylinder works.

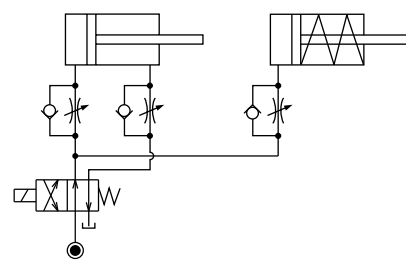

- ② In the case of meter-out circuit, the inner circuit pressure may increase during the cylinder action because of the fluid supply. The increase of the inner circuit pressure can be prevented by reducing the supplied fluid beforehand via the flow control valve. Especially when using sequence valve or pressure switches for clamping detection. If the back pressure is more than the set pressure then the system will not work as it is designed to.

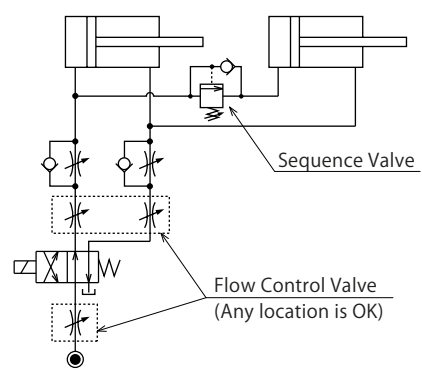

ⓘ Cautions

● Notes on Handling

- 1) It should be operated by qualified personnel.
 - Machines and devices with hydraulic and pneumatic products should be operated and maintained by qualified personnel.
- 2) Do not operate or remove the product unless the safety protocols are ensured.
 - ① Machines and devices can only be inspected or prepared when it is confirmed that the safety devices are in place.
 - ② Before the product is removed, make sure that the above-mentioned safety devices are in place. Shut off the pressure and power source, and make sure no pressure exists in the air and hydraulic circuits.
 - ③ After stopping the product, do not remove until the temperature drops.
 - ④ Make sure there is no trouble/issue in the bolts and respective parts before restarting a machine or device.
- 3) Do not touch a clamp (cylinder) while it is working. Otherwise, your hands may be injured due to clinching.

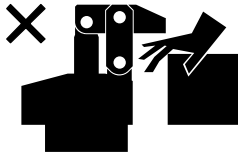

- 4) Do not disassemble or modify.
 - If the equipment is taken apart or modified, the warranty will be voided even within the warranty period.

● Maintenance and Inspection

- 1) Removal of the Machine and Shut-off of Pressure Source
 - Before the machine is removed, make sure that safety devices and preventive devices are in place. Shut off the pressure and power source, and make sure no pressure exists in the air and hydraulic circuits.
 - Make sure there is no abnormality in the bolts and respective parts before restarting.
- 2) Regularly clean the area around the piston rod.
 - If it is used when the surface is contaminated with dirt, it may lead to packing seal damage, malfunctioning and fluid leakage.

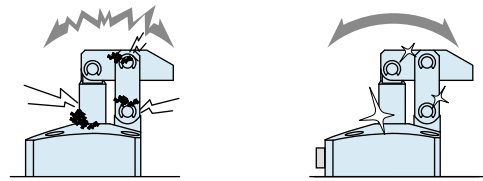

- 3) If disconnecting by couplers, air bleeding should be carried out on a regular basis to avoid air mixed in the circuit.
- 4) Regularly tighten pipe line, mounting bolt, nut, snap ring, cylinder and others to ensure proper use.
- 5) Make sure the hydraulic fluid has not deteriorated.
- 6) Make sure there is a smooth action without an irregular noise.
 - Especially when it is restarted after left unused for a long period, make sure it can be operated correctly.
- 7) The products should be stored in the cool and dark place without direct sunshine or moisture.
- 8) Please contact us for overhaul and repair.

● Warranty

1) Warranty Period

- The product warranty period is 18 months from shipment from our factory or 12 months from initial use, whichever is earlier.

2) Warranty Scope

- If the product is damaged or malfunctions during the warranty period due to faulty design, materials or workmanship, we will replace or repair the defective part at our expense.

Defects or failures caused by the following are not covered.

- ① If the stipulated maintenance and inspection are not carried out.
- ② If the product is used while it is not suitable for use based on the operator's judgment, resulting in defect.
- ③ If it is used or operated in an inappropriate way by the operator. (Including damage caused by the misconduct of the third party.)
- ④ If the defect is caused by reasons other than our responsibility.
- ⑤ If repair or modifications are carried out by anyone other than Kosmek, or without our approval and confirmation, it will void warranty.
- ⑥ Other caused by natural disasters or calamities not attributable to our company.
- ⑦ Parts or replacement expenses due to parts consumption and deterioration. (Such as rubber, plastic, seal material and some electric components.)

Damages excluding from direct result of a product defect shall be excluded from the warranty.



KOSMEK LTD.

▶ <https://www.kosmek.com/>

HEAD OFFICE 1-5, 2-chome, Murotani, Nishi-ku, Kobe-city, Hyogo, Japan 651-2241
TEL.+81-78-991-5162 FAX.+81-78-991-8787

United States of America SUBSIDIARY	KOSMEK (USA) LTD. 650 Springer Drive, Lombard, IL 60148 USA TEL. +1-630-620-7650 FAX. +1-630-620-9015
MEXICO BRANCH OFFICE	KOSMEK USA MEXICO BRANCH OFFICE Av. Loma Pinal de Amoles 320-piso PH oficina 504 interior 13, Vista Dorada, 76060 Santiago de Querétaro, Qro. Mexico TEL. +52-442-851-1377
EUROPE SUBSIDIARY	KOSMEK EUROPE GmbH Schleppeplatz 2 9020 Klagenfurt am Wörthersee Austria TEL. +43-463-287587 FAX. +43-463-287587-20
CHINA SUBSIDIARY	KOSMEK (CHINA) LTD. Room601, RIVERSIDE PYRAMID No.55, Lane21, Pusan Rd, Pudong Shanghai 200125, China TEL. +86-21-54253000
INDIA BRANCH	KOSMEK LTD. - INDIA 4A/Old No:649, Ground Floor, 4th D cross, MM Layout, Kavalbyrasandra, RT Nagar, Bangalore -560032 India TEL.+91-9880561695
THAILAND REPRESENTATIVE OFFICE	KOSMEK Thailand Representation Office No.139, Blue Chips Building, 4th Floor, Room No.422, Soi Sukhumvit 63 (Thong Lor 10), Sukhumvit Road, Khlong Tan Nuea, Wattana, Bangkok 10110, Thailand TEL. +66(0)2-059-2010

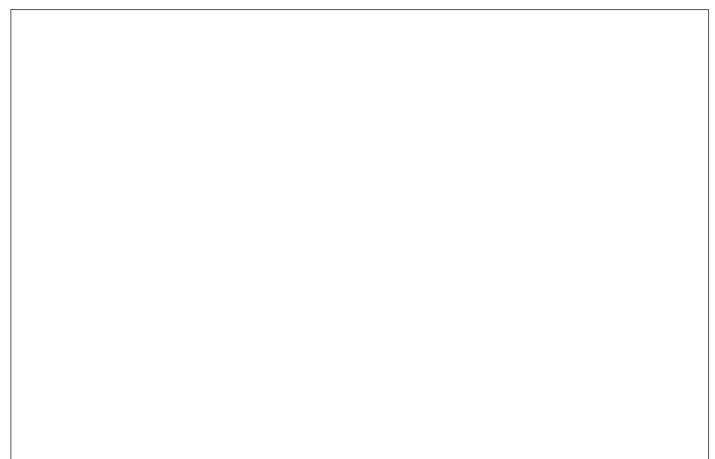

- For Further Information on Unlisted Specifications and Sizes, Please call us.
- Specifications in this Leaflet are Subject to Change without Notice.



New Wireless Sensing Clamp HYD. LOCK / HYD. RELEASE
Swing / Link Clamp • Linear Cylinder



Swing Clamp
model **LHM**



Link Clamp
model **LKM**



Linear Cylinder
model **LLM**

Wirelessly Detect Unclamp Position

No External Power Supply

Required for Sensor