

New Wireless Sensing Clamp **HYD. LOCK / HYD. RELEASE**
Swing / Link Clamp • Linear Cylinder



Swing Clamp
model **LHM**



Link Clamp
model **LKM**



Linear Cylinder
model **LLM**

Wirelessly Detect Unclamp Position

No External Power Supply

Required for Sensor

NEW

HYD. LOCK / HYD. RELEASE

Wireless Sensing Clamp



Swing Clamp
model **LHM**



Link Clamp
model **LKM**



Linear Cylinder
model **LLM**

Wirelessly Detect Unclamp Position

No External Power Supply Required for Sensor



Individual Detection

Separate unclamp detection is possible for each clamp.



Waterproof Rating

Equivalent to **IPX7**

※ Shows the protection level of the sensor.



Response Time

0.1sec.

Quick Response[※]

※ Compared with our conventional air sensing clamps.

Minimized Number of Ports

Solution to fixture port shortage.

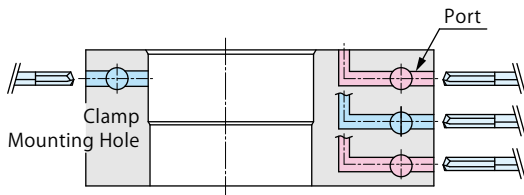

With
Wireless
Sensing

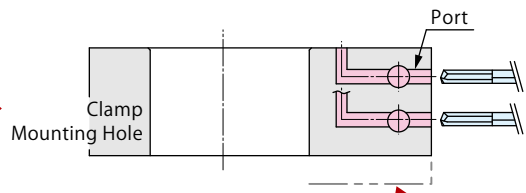

Conventional Fixture※ : Multiple Ports

Hydraulic Port × 2, Air Port × 1, Vent Port × 1

※Using our conventional air sensing clamp (model LHW-J)

Air port is not required.

Hydraulic Port × 2

Enables a thinner
and lighter fixture.

Lower Design • Fixture Cost

Design & machining costs for sensing ports are not required.

※ Image compared with our conventional air sensing clamps.



With
Wireless
Sensing



Conventional※ sensing function needed design and machining costs for ports.

※ For conventional models, please see the "Changes in Sensing Clamps" .

Fixture is simplified.

Zero Air Consumption

Detect unclamp position via wireless communication.

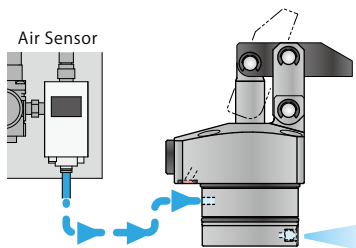

Consumes air for detection.

※ Using our conventional air sensing clamp.

With
Wireless
Sensing

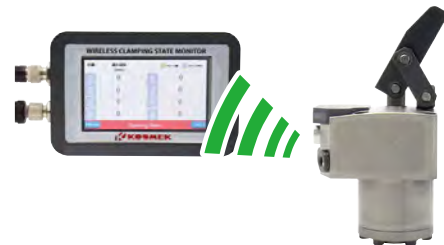

Detects wirelessly, zero air consumption.

Changes in Sensing Clamps

Model	Air Sensor Model Conventional	Air Sensing Valve Model Conventional	Wireless Sensing Model NEW
Air Consumption	High	Low	Zero
Cylinder Length	Long (High Interference)	Short	Short

Please contact us when considering the wireless sensing clamp.

Wireless Sensing Swing Clamp

Hydraulic Double Action

Model LHM



Wirelessly Detect Unclamp Position.
Number of Ports is Reduced.

No External Power Supply Required for Sensor

Detects unclamp position wirelessly.

Receiver

Place : Outside Machine

Repeater

Place : Near Fixture
Inside the Processing Machine

Clamp

Place : Fixture



Action Description

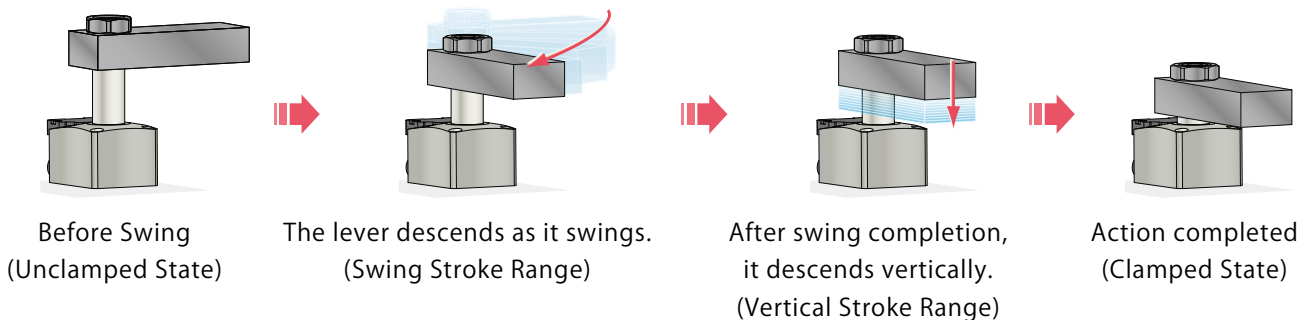

● Cross Section ※ This drawing shows Model LHM-C□-B□.

Excellent Coolant Resistance

Our exclusive dust seal is designed to protect against high pressure coolant. It also has high durability against chlorine-based coolant by using a sealing material with excellent chemical resistance.

Direct Mount Speed Control Valve

Speed control valve with air bleeding function can be directly mounted to the product. (Speed control valve is sold separately.)

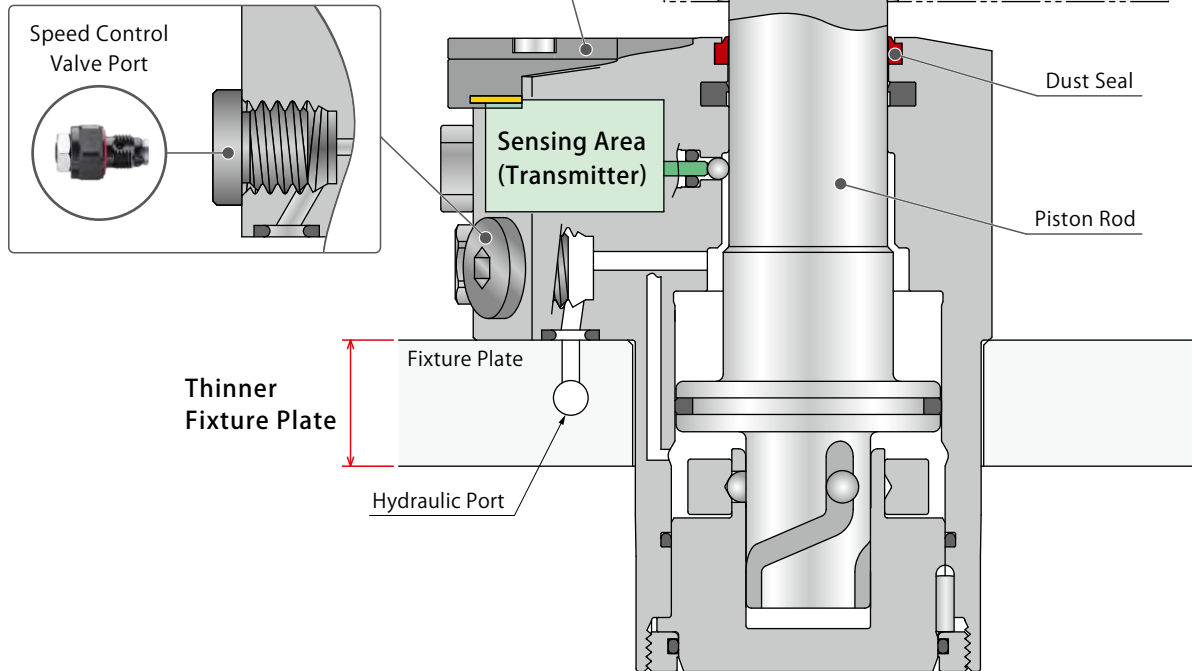

High Speed and High Endurance with Rotation Mechanism

The resistance created by the swing action is minimized by having the outer race rotate in accordance with the steel ball movement. High endurance is achieved by enlarging rod diameter which decreases torque and by using bigger steel balls and making the lead groove. (Position repeatability for swing is within $\pm 0.5^\circ$.)

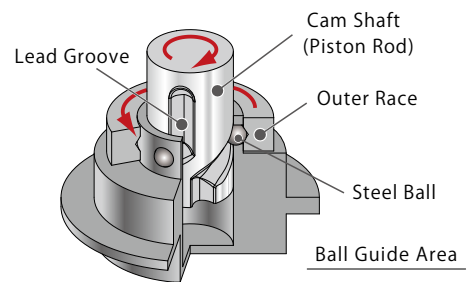

Zero Air Consumption

Detects unclamp position via wireless communication. Unlike our conventional air sensing clamps, air for action confirmation is not required.



Minimized Number of Ports • Simple Machining

Integrating ports allows for reducing the number of ports for Rotary Joint and machining for air passage of fixture plate, and simplifying the machining of mounting hole, etc.

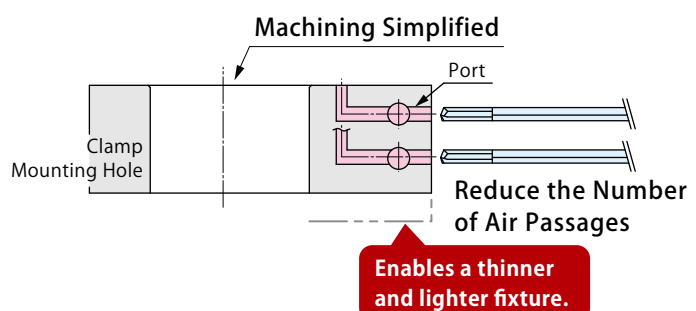

Wireless Sensing Clamp

Accessory

Common Cautions

Wireless Sensing Swing Clamp

LHM

Wireless Sensing Link Clamp

LKM

Wireless Sensing Linear Cylinder

LLM

Receiver • Repeater

YWA

YWB

● Action Description (Internal Structure) ※ The figure shows Model LHM-C□-B□.

Unclamp

Receiver ※ Refer to the website and catalog (model YWA) for further information



Unclamp Signal

Distance to receiver : Max. 5m

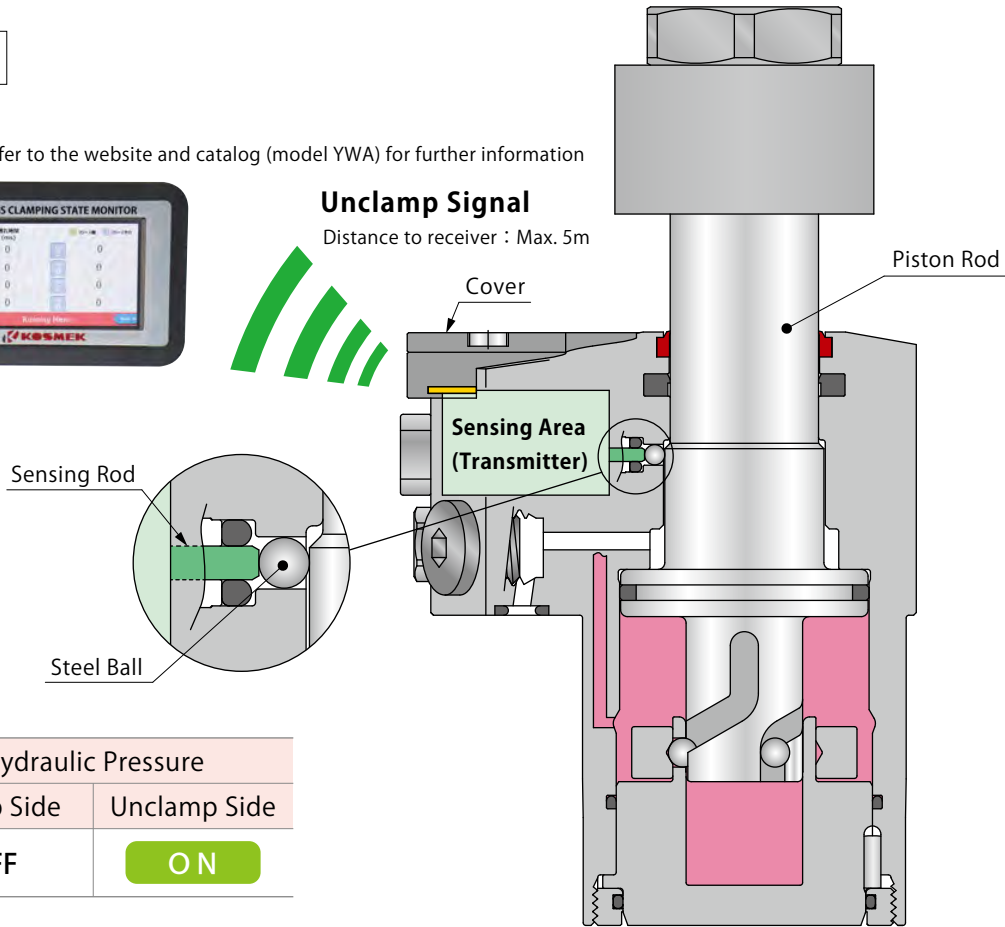

■ **Unclamp (During Hydraulic Pressure Supply to Unclamping Port)**

The piston rod ascends vertically (Vertical Stroke Range).



After vertical action is completed, the piston rod ascends as it swings.



When the piston rod pushes the sensing rod via the steel ball at the unclamp end, an unclamp signal is transmitted from the sensing area.

Connecting Multiple Wireless Sensing Clamps

When using multiple wireless sensing clamps, provide an unclamp operating time difference of 100msec (0.1 sec.) or more. Please check the operating time at the receiver, and adjust the operating time with the speed control valve if it is within 100msec. Otherwise, signals cannot be received properly due to radio interference.

Clamp

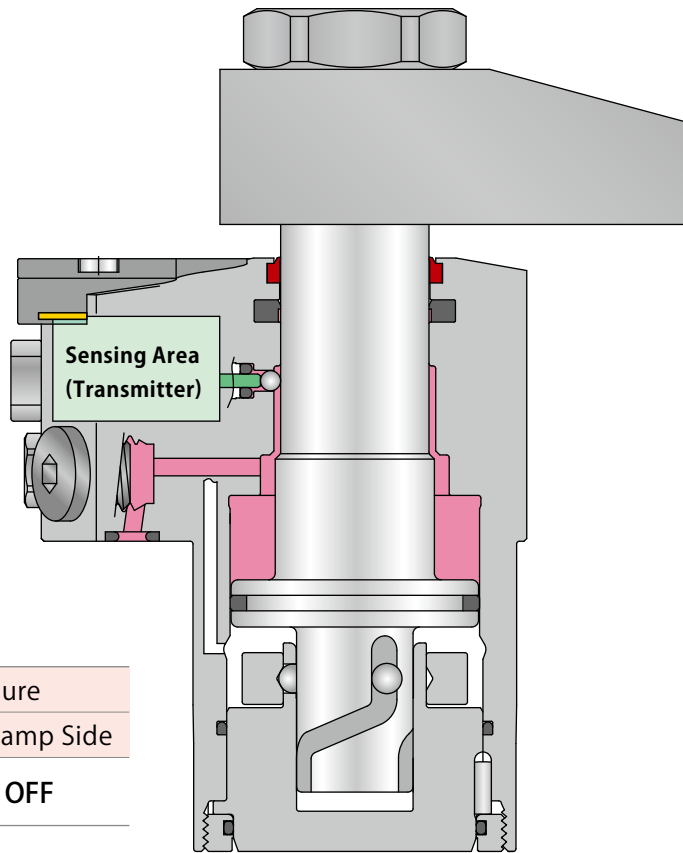

Hydraulic Pressure	
Clamp Side	Unclamp Side
ON	OFF

■ Clamp (During Hydraulic Pressure Supply to Clamping Port)

The piston rod descends as it swings (Swing Stroke Range).



After swing action is completed, the piston rod descends vertically to clamp the workpiece.

※ Make sure to clamp a workpiece within the vertical stroke range.

Wireless Sensing Clamp

Accessory

Common Cautions

Wireless Sensing Swing Clamp

LHM

Wireless Sensing Link Clamp

LKM

Wireless Sensing Linear Cylinder

LLM

Receiver · Repeater

YWA

YWB

● Model No. Indication

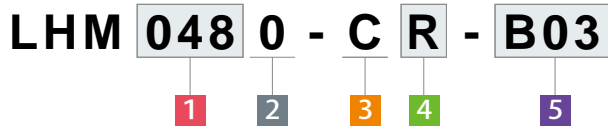

1 Body Size

- 048** : $\phi D=48\text{mm}$
- 055** : $\phi D=55\text{mm}$
- 065** : $\phi D=65\text{mm}$
- 075** : $\phi D=75\text{mm}$

※ Indicates the cylinder outer diameter (ϕD).

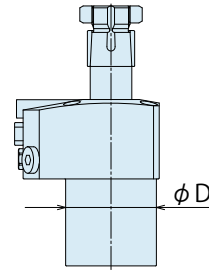

2 Design No.

- 0** : Revision Number

3 Piping Method

- C** : Gasket Option (With G Thread Plug)

※ Speed control valve (BZL) is sold separately. Please refer to P. 55.

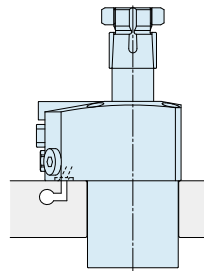

With G Thread Plug
Able to attach speed control valve

4 Swing Direction when Clamping

- R** : Clockwise
- L** : Counter-Clockwise

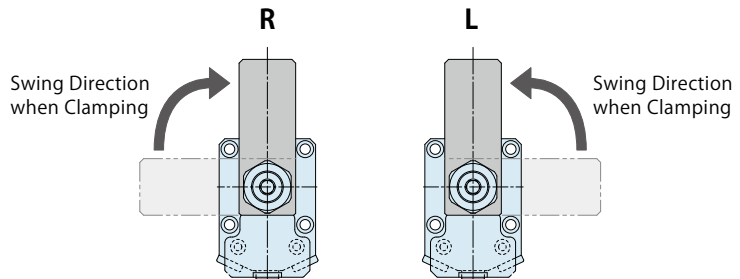

5 Available Country : Frequency

- B01** : Japan
- B02** : Europe, China
- B03** : United States

※ There are restrictions on countries where the product can be used according to radio regulations. Please follow the regulatory requirements of each country.

Specifications

Model No.		LHM0480-C□-B□	LHM0550-C□-B□	LHM0650-C□-B□	LHM0750-C□-B□
Cylinder Area for Clamping	cm ²	6.95	10.3	13.4	20.3
Cylinder Inner Diameter ※1	mm	37	44	51	62
Rod Diameter ※1	mm	22	25	30	35.5
Clamping Force ※2 (Calculation Formula)	kN	$F = \frac{P(1-0.0009 \times L)}{1.4892+0.0018 \times L}$	$F = \frac{P(1-0.0011 \times L)}{1.0039+0.0011 \times L}$	$F = \frac{P(1-0.0009 \times L)}{0.7822+0.0010 \times L}$	$F = \frac{P(1-0.0007 \times L)}{0.5175+0.0006 \times L}$
Full Stroke	mm	15.5	18.5	20	24
Swing Stroke (90°)	mm	7.5	8.5	10	12
Vertical Stroke	mm	8	10	10	12
Swing Angle Accuracy		90° ±3°			
Swing Complete Position Repeatability		±0.5°			
Max. Operating Pressure	MPa	7			
Min. Operating Pressure ※3	MPa	1.5			
Withstanding Pressure	MPa	10.5			
Operating Temperature	°C	0 ~ 70 (Sensing Area: ~ 60°C)			
Usable Fluid		General Hydraulic Oil Equivalent to ISO-VG-32			
Wireless Sensing (Unclamp Confirmation)	Frequency	5 When selecting B01 : 920MHz Band ----- 5 When selecting B02 : 868MHz Band ----- 5 When selecting B03 : 902MHz Band			
	Distance to Receiver	Max. 5m ※4			
	Sensing Position	ON from 10° swing angle before the unclamp end stroke.			
	Waterproof Rating	Equal to IPX7 (When the cover of the sensing area is completely closed.)			

Notes : ※1. Clamping force cannot be calculated from the cylinder inner diameter and rod diameter.

Please refer to the clamping force calculation formula and the clamping force curve.

※2. F : Clamping Force (kN), P : Supply Hydraulic Pressure (MPa), L : Distance between the piston center and the clamping point (mm).

※3. Minimum pressure to operate the clamp without load.

※4. The maximum distance when there is no obstruction. Check the radio wave strength displayed on the receiver and consider the location of the repeater. (Recommended Threshold Value: -85dBm)

1. Please refer to the external dimensions for cylinder capacity and product weight.

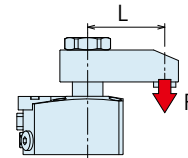

Wireless Sensing Clamp

Accessory

Common Cautions

Wireless Sensing Swing Clamp

LHM

Wireless Sensing Link Clamp

LKM

Wireless Sensing Linear Cylinder

LLM

Receiver · Repeater

YWA

YWB

Clamping Force Curve

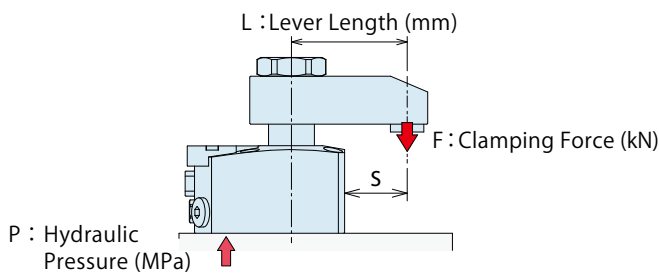

Applicable Model

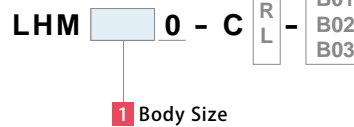

(Ex.) In case of LHM0480 :

When supply hydraulic pressure P is 5.0MPa and lever length L is 50mm, clamping force becomes about 3.1kN.

Notes :

1. Tables and graphs show the relationship between the clamping force (kN) and supply hydraulic pressure (MPa).
 2. Cylinder force (when L=0) cannot be calculated from the formula of clamping force.
 3. Lever with a large inertia sometimes does not work depending on supply hydraulic pressure, lever mounting position, etc.
 4. Values in below charts indicate clamping force when the lever locks a workpiece in horizontal position.
 5. The clamping force varies depending on the lever length. Set the suitable supply hydraulic pressure based on the lever length.
 6. Clamping force in the non-usable range may cause damage and fluid leakage.
 7. The tables and graphs are only for reference. The exact results should be calculated based on the clamping force calculation formula.
- ※ 1. F : Clamping Force (kN), P : Supply Hydraulic Pressure (MPa), L : Lever Length (mm).

LHM0480		Clamping Force Calculation Formula ※1 (kN) $F = P(1-0.0009 \times L) / (1.4892+0.0018 \times L)$									
Hydraulic Pressure (MPa)	Cylinder Force (kN)	Clamping Force (kN)								Non-Usable Range (■)	Max. Lever Length (L) (mm)
		Lever Length L (mm)									
		L=50	L=60	L=80	L=100	L=120	L=140	L=160	L=200		
7	4.87	4.3	4.2	4.0	3.9	3.7	3.6	3.6			141
6.5	4.52	4.0	3.9	3.7	3.6	3.4	3.3				157
6	4.17	3.7	3.6	3.5	3.3	3.2	3.1	2.9			178
5.5	3.82	3.4	3.3	3.2	3.0	2.9	2.8	2.7	2.5		204
5	3.48	3.1	3.0	2.9	2.8	2.7	2.6	2.5	2.3		230
4.5	3.13	2.8	2.7	2.6	2.5	2.4	2.3	2.2	2.0		230
4	2.78	2.5	2.4	2.3	2.2	2.1	2.1	2.0	1.8		230
3.5	2.43	2.2	2.1	2.0	2.0	1.9	1.8	1.7	1.6		230
3	2.09	1.9	1.8	1.7	1.7	1.6	1.6	1.5	1.4		230
2.5	1.74	1.6	1.5	1.5	1.4	1.4	1.3	1.2	1.2		230
2	1.39	1.3	1.2	1.2	1.1	1.1	1.0	1.0	0.9		230
1.5	1.04	1.0	0.9	0.9	0.9	0.8	0.8	0.8	0.7		230
Max. Operating Pressure (MPa)		7.0	7.0	7.0	7.0	7.0	7.0	6.6	5.7		

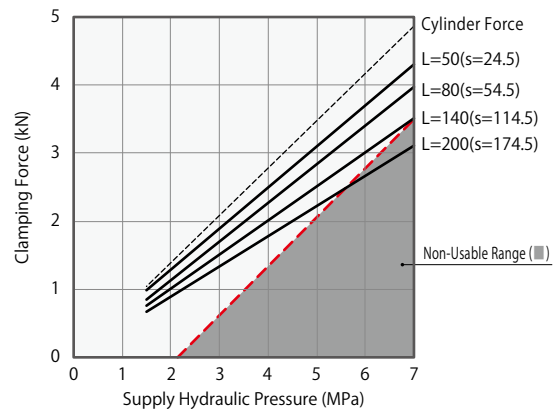

LHM0550		Clamping Force Calculation Formula ※1 (kN) $F = P(1-0.0011 \times L) / (1.0039+0.0011 \times L)$									
Hydraulic Pressure (MPa)	Cylinder Force (kN)	Clamping Force (kN)								Non-Usable Range (■)	Max. Lever Length (L) (mm)
		Lever Length L (mm)									
		L=50	L=60	L=80	L=100	L=120	L=140	L=160	L=200		
7	7.21	6.3	6.2	5.9	5.6	5.4	5.2				142
6.5	6.69	5.8	5.7	5.5	5.2	5.0	4.8				159
6	6.18	5.4	5.3	5.1	4.8	4.6	4.4	4.2			180
5.5	5.66	5.0	4.8	4.6	4.4	4.2	4.1	3.9	3.6		209
5	5.15	4.5	4.4	4.2	4.0	3.9	3.7	3.5	3.2		245
4.5	4.63	4.1	4.0	3.8	3.6	3.5	3.3	3.2	2.9		245
4	4.12	3.6	3.5	3.4	3.2	3.1	3.0	2.8	2.6		245
3.5	3.60	3.2	3.1	3.0	2.8	2.7	2.6	2.5	2.3		245
3	3.09	2.7	2.7	2.6	2.4	2.3	2.2	2.1	2.0		245
2.5	2.57	2.3	2.2	2.1	2.0	2.0	1.9	1.8	1.6		245
2	2.06	1.8	1.8	1.7	1.6	1.6	1.5	1.4	1.3		245
1.5	1.54	1.4	1.4	1.3	1.2	1.2	1.1	1.1	1.0		245
Max. Operating Pressure (MPa)		7.0	7.0	7.0	7.0	7.0	7.0	6.4	5.6		

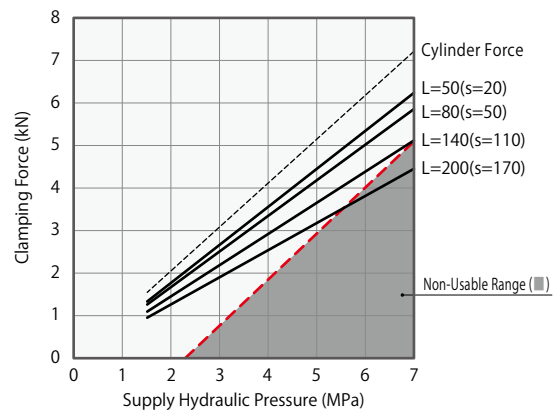

Wireless Sensing Clamp

Accessory

Common Cautions

Wireless Sensing Swing Clamp

LHM

Wireless Sensing Link Clamp

LKM

Wireless Sensing Linear Cylinder

LLM

Receiver Repeater

YWA

YWB

LHM0650		Clamping Force Calculation Formula ^{*1} (kN) $F = P(1-0.0009 \times L) / (0.7822+0.0010 \times L)$									
Hydraulic Pressure (MPa)	Cylinder Force (kN)	Clamping Force (kN)								Non-Usable Range (mm)	Max. Lever Length L (mm)
		L=50	L=60	L=80	L=100	L=120	L=140	L=160	L=200		
7	9.35	8.1	7.9	7.6	7.3	7.3					115
6.5	8.68	7.5	7.3	7.0	6.7	6.5					127
6	8.02	6.9	6.8	6.5	6.2	6.0	5.7				142
5.5	7.35	6.4	6.2	6.0	5.7	5.5	5.3	5.0			161
5	6.68	5.8	5.7	5.4	5.2	5.0	4.8	4.6			187
4.5	6.01	5.2	5.1	4.9	4.7	4.5	4.3	4.1	3.8		221
4	5.34	4.6	4.5	4.4	4.2	4.0	3.8	3.7	3.4	260	
3.5	4.68	4.1	4.0	3.8	3.7	3.5	3.4	3.2	3.0	260	
3	4.01	3.5	3.4	3.3	3.1	3.0	2.9	2.8	2.5	260	
2.5	3.34	2.9	2.9	2.7	2.6	2.5	2.4	2.3	2.1	260	
2	2.67	2.3	2.3	2.2	2.1	2.0	1.9	1.9	1.7	260	
1.5	2.00	1.8	1.7	1.7	1.6	1.5	1.5	1.4	1.3	260	
Max. Operating Pressure (MPa)	7.0	7.0	7.0	7.0	7.0	6.8	6.1	5.6	4.8		

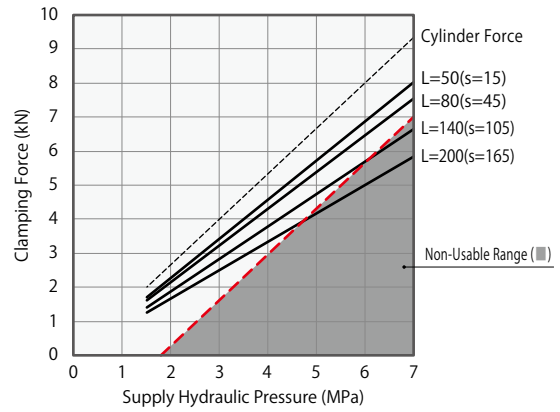

LHM0750		Clamping Force Calculation Formula ^{*1} (kN) $F = P(1-0.0007 \times L) / (0.5175+0.0006 \times L)$									
Hydraulic Pressure (MPa)	Cylinder Force (kN)	Clamping Force (kN)								Non-Usable Range (mm)	Max. Lever Length L (mm)
		L=50	L=60	L=80	L=100	L=120	L=140	L=160	L=200		
7	14.21	12.4	12.2	11.7	11.3	10.9	10.5				147
6.5	13.19	11.5	11.3	10.9	10.5	10.2	9.8	9.5			163
6	12.18	10.6	10.4	10.1	9.7	9.4	9.0	8.7			184
5.5	11.16	9.7	9.6	9.2	8.9	8.6	8.3	8.0	7.5		209
5	10.15	8.9	8.7	8.4	8.1	7.8	7.5	7.3	6.8		244
4.5	9.13	8.0	7.8	7.6	7.3	7.0	6.8	6.6	6.1		280
4	8.12	7.1	7.0	6.7	6.5	6.3	6.0	5.8	5.4		280
3.5	7.10	6.2	6.1	5.9	5.7	5.5	5.3	5.1	4.8		280
3	6.09	5.3	5.2	5.1	4.9	4.7	4.5	4.4	4.1		280
2.5	5.07	4.5	4.4	4.2	4.1	3.9	3.8	3.7	3.4		280
2	4.06	3.6	3.5	3.4	3.3	3.2	3.0	2.9	2.7		280
1.5	3.04	2.7	2.6	2.5	2.5	2.4	2.3	2.2	2.1		280
Max. Operating Pressure (MPa)	7.0	7.0	7.0	7.0	7.0	7.0	7.0	6.9	5.9		

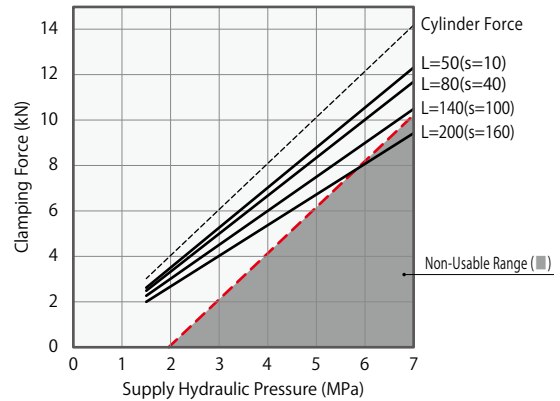

● Allowable Swing Time Graph

Adjustment of Swing Time

The graph shows allowable swing time against the moment of inertia of a lever. An operation time should be longer than the operation time shown in the graph.

Excessive action speed can reduce stopping accuracy and damage internal components.

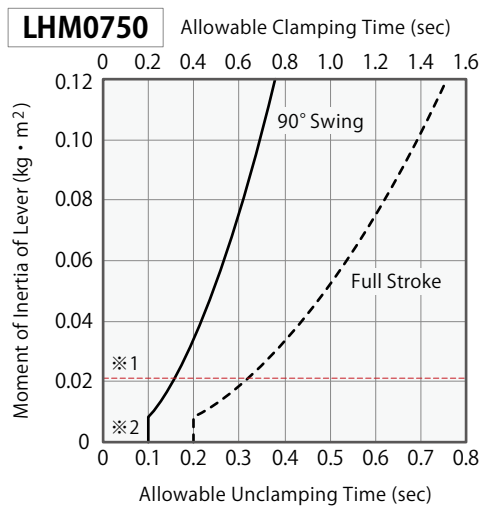
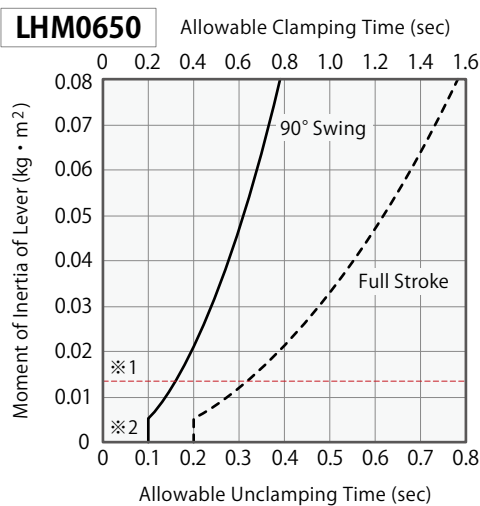
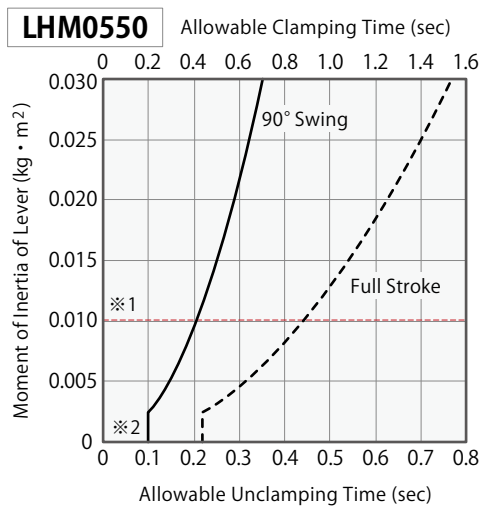
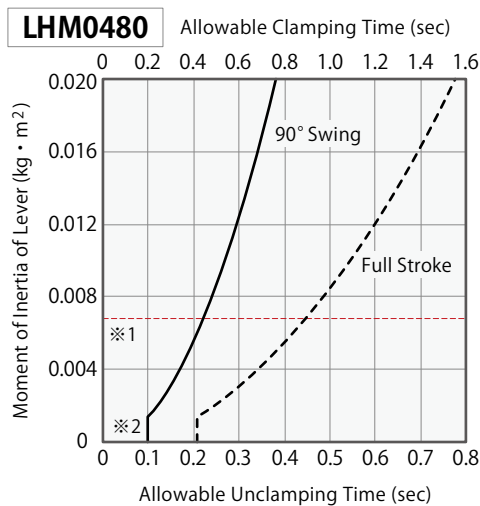
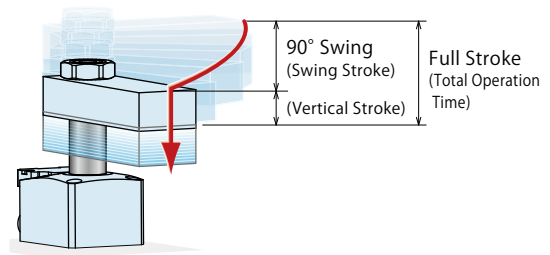

Notes :

- ※1. It shows the moment of inertia of material lever (LZH□-T).
- ※2. For any moment of inertia of a lever, the minimum 90° swing time should be 0.2 sec for clamping and 0.1 sec for unclamping or more.
 1. The graph shows the allowable action time in regard to the moment of inertia of lever when the piston rod operates at constant speed.
 2. There may be no lever swing action with large inertia depending on supply hydraulic pressure, oil flow and lever mounting position.
 3. For speed adjustment of clamp lever, please use meter-out flow control valve.
 - In case of meter-in control, the clamp lever may be accelerated by its own weight during swinging motion (clamp mounted horizontally) or the piston rod may be moving too fast. Please refer to P.60 for speed control of the hydraulic cylinder.
 4. Excessive swing speed can reduce stopping accuracy and damage the internal components.
 5. Please contact us if operational conditions differ from those shown on the graphs.

(How to read the allowable swing time graph)

In case of LHM0480

The moment of inertia of a lever : 0.0068kg·m²

① 90° Swing Time when Clamping : About 0.44 sec or more

② 90° Swing Time when Unclamping : About 0.22 sec or more

③ Total Clamp Operation Time : About 0.9 sec or more

④ Total Unclamp Operation Time : About 0.45 sec or more

1. The total operation time on the graph represents the allowable operation time when fully stroked.

Model →

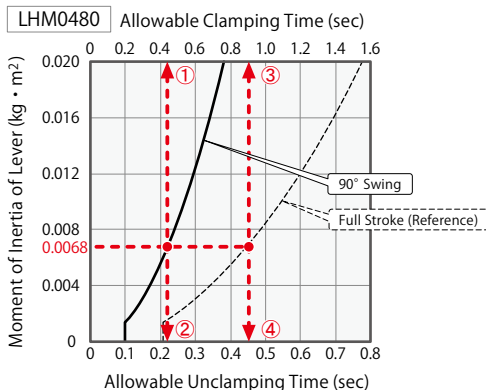

How to Calculate the Moment of Inertia (Estimated)

I : Moment of Inertia (kg·m²) L,L₁,L₂,K,b : Length (m) m,m₁,m₂,m₃ : Mass (kg)

- ① For a rectangular plate (cuboid), the rotating shaft is vertically on one side of the plate.

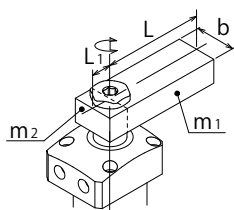

$$I = m_1 \frac{4L^2 + b^2}{12} + m_2 \frac{4L_1^2 + b^2}{12}$$

- ② For a rectangular plate (cuboid), the rotating shaft is vertically on the gravity center of the plate.

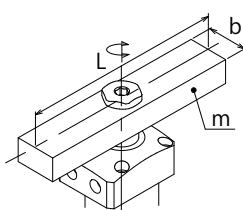

$$I = m \frac{L^2 + b^2}{12}$$

- ③ Load is applied on the lever front end.

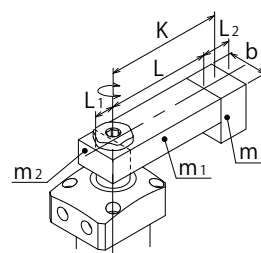

$$I = m_1 \frac{4L^2 + b^2}{12} + m_2 \frac{4L_1^2 + b^2}{12} + m_3 K^2 + m_3 \frac{L_2^2 + b^2}{12}$$

Calculation Formula of Total Operation Time

$$\text{Total Clamp Operation Time (sec)} = 90^\circ \text{ Swing Time when Clamping (sec)} \times \frac{\text{Full Stroke (mm)}}{\text{Swing Stroke (mm)}}$$

$$\text{Total Unclamp Operation Time (sec)} = 90^\circ \text{ Swing Time when Unclamping (sec)} \times \frac{\text{Full Stroke (mm)}}{\text{Swing Stroke (mm)}}$$

External Dimensions

C : Gasket Option (With G Thread Plug)

※ The drawing shows the unclamped state of LHM-CR-B□.

LHM0480-C□-B□ / LHM0550-C□-B□

LHM0650-C□-B□ / LHM0750-C□-B□

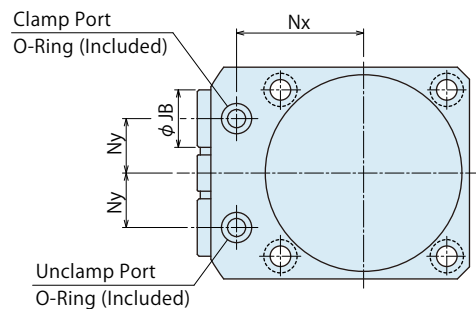
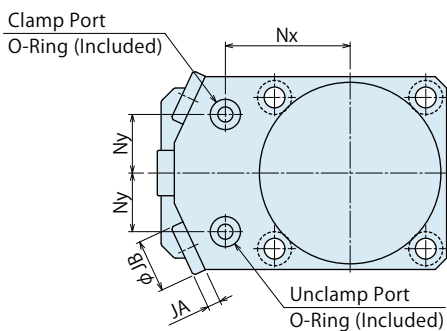
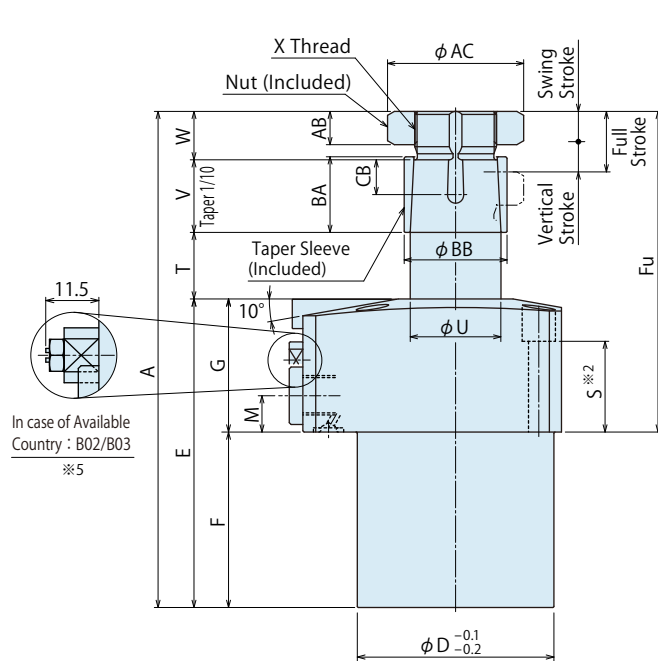
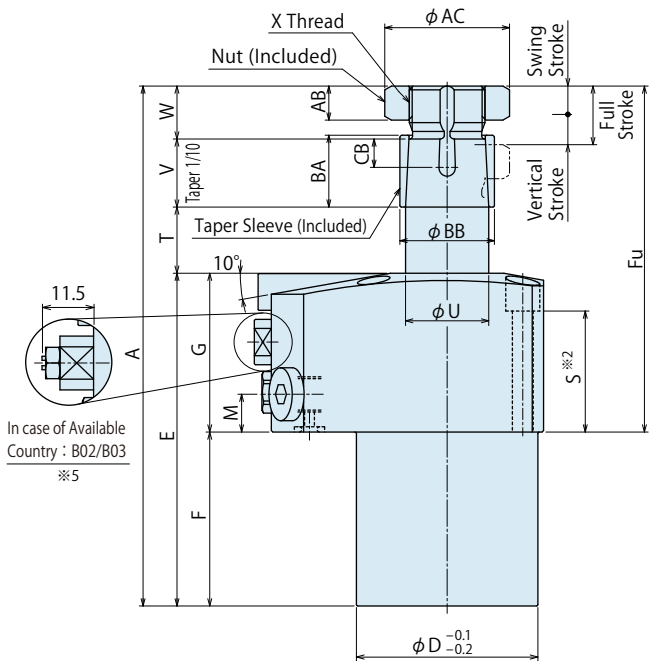
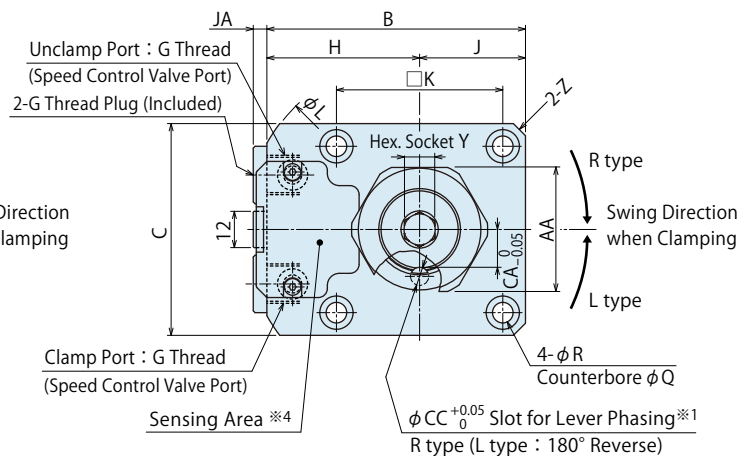
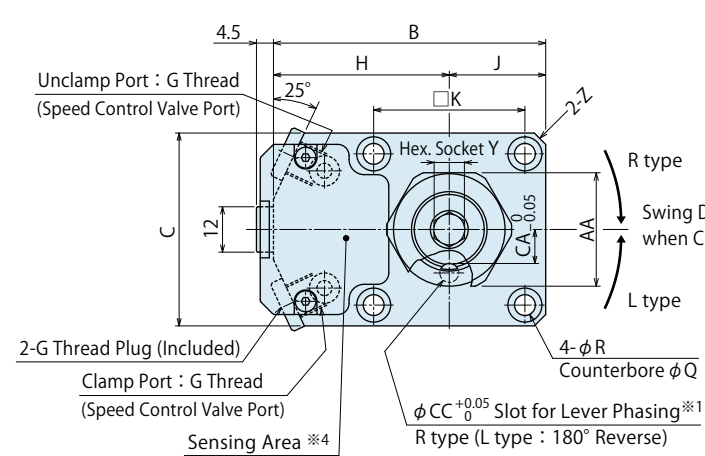

Notes:

- ※1. The slot for lever phasing faces the port side when clamped.
- ※2. Mounting bolts are not provided. Please prepare them according to the mounting height referring to dimension 'S'.
- ※3. Speed control valve is sold separately. Please refer to P.55. It is necessary to provide an unclamp operation time difference of at least 100 msec. For adjusting the unclamp operation, please use a speed control valve.
- ※4. Do not cover the top surface of the sensing area with metal objects (chips, sludge, etc.). It may obstruct radio wave transmission.
- ※5. Please refer to P.17 "Notes for Design 2) Radio Regulations".

Model No. Indication

(Format Example : LHM0550-CR-B02, LHM0750-CL-B03)

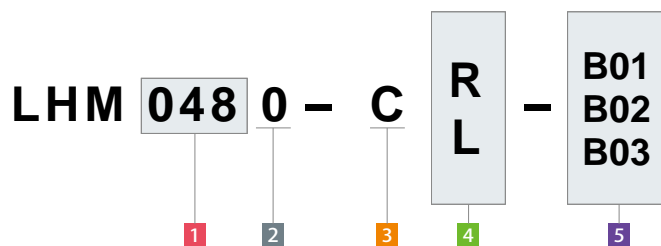

1 Body Size

2 Design No.

3 Piping Method

4 Swing Direction when Clamping

5 Available Country : Frequency

Wireless Sensing Clamp

Accessory

Common Cautions

Wireless Sensing Swing Clamp

LHM

Wireless Sensing Link Clamp

LKM

Wireless Sensing Linear Cylinder

LLM

Receiver · Repeater

YWA

YWB

Machining Dimensions of Mounting Area

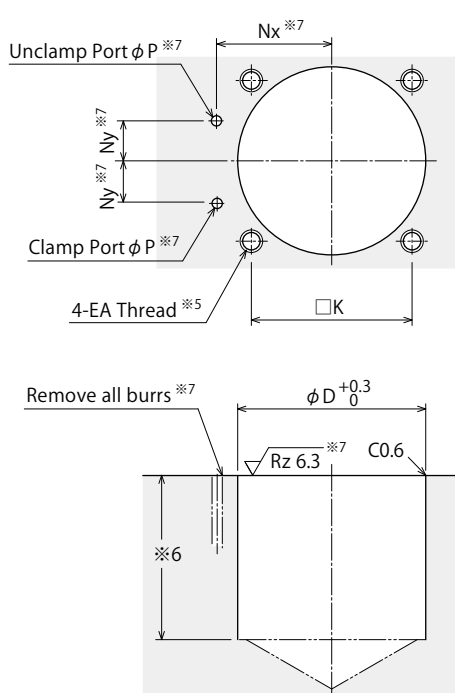

Notes :

- ※5. EA tapping depth of the mounting bolt should be decided according to the mounting height referring to dimension 'S'.
- ※6. The depth of the body mounting hole ϕD should be decided according to the mounting height referring to dimension 'F'.
- ※7. The machining dimension is for -C: Gasket Option.

External Dimensions and Machining Dimensions for Mounting

(mm)

Model No.	LHM0480-C-B	LHM0550-C-B	LHM0650-C-B	LHM0750-C-B	
Full Stroke	15.5	18.5	20	24	
Swing Stroke (90°)	7.5	8.5	10	12	
Vertical Stroke	8	10	10	12	
A	137.5	153.5	164	181	
B	72	78	85.5	93.3	
C	51	60	70	80	
D	48	55	65	75	
E	88	97	102	109	
F	46	55	58	65	
Fu	91.5	98.5	106	116	
G	42	42	44	44	
H	46.5	48	50.5	53.3	
J	25.5	30	35	40	
K	40	47	55	63	
L	-	-	116	122	
M	10	10	12	12	
Nx	33	34.5	42	45	
Ny	15.5	16	18	19	
P	3	3	5	5	
Q	9	10.5	11	14	
R	5.5	6.8	6.8	9	
S	32	30	30	27	
T	17.5	20.5	22	26	
U	22	25	30	35.5	
V	18	21	24	30	
W	14	15	16	16	
X (Nominal × Pitch)	M20×1.5	M22×1.5	M27×1.5	M30×1.5	
Y	8	8	10	10	
Z (Chamfer)	C3	C3	C4	C5	
AA	30	32	41	46	
AB	9	10	11	11	
AC	33	35.5	45	50	
BA	19	22	25	31	
BB	25	28	34	40	
CA	9	10	12.5	14	
CB	7.5	9.5	11.5	12.5	
CC	5	6	6	8	
EA	M5×0.8	M6×1	M6×1	M8×1.25	
JA	3.5	3.5	4.5	4.5	
JB	14	14	19	19	
Clamp Port : G Thread	G1/8	G1/8	G1/4	G1/4	
Unclamp Port : G Thread	G1/8	G1/8	G1/4	G1/4	
O-ring	OR NBR-90 P5-N	OR NBR-90 P5-N	OR NBR-90 P7-N	OR NBR-90 P7-N	
Cylinder	Clamp	10.8	19	26.7	48.7
Capacity cm ³	Unclamp	16.7	28.1	40.9	72.5
Weight ^{※8}	kg	1.6	2.2	3.2	4.3

Note : ※8. It shows the weight of single swing clamp including taper sleeve and nut.

Taper Lock Lever Design Dimensions

※ Reference for designing a taper lock swing lever.

Corresponding Model No.

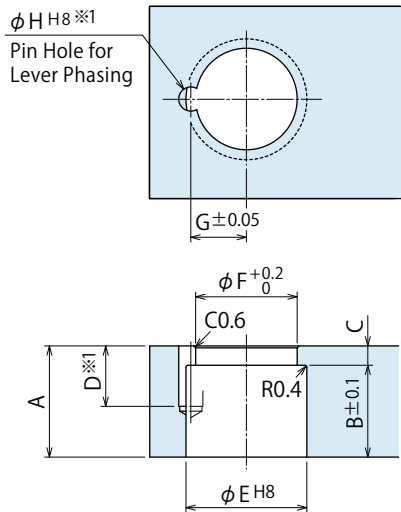
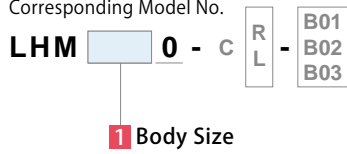

Corresponding Model No.	(mm)			
	LHM0480 -C□-B□	LHM0550 -C□-B□	LHM0650 -C□-B□	LHM0750 -C□-B□
A	23	26	29	35
B	19	22	25	31
C	4	4	4	4
D	12.5	14.5	16.5	17.5
E	25 $^{+0.033}_0$	28 $^{+0.033}_0$	34 $^{+0.039}_0$	40 $^{+0.039}_0$
F	21	23.5	29	33
G	11.5	13	15.5	18
H	5 $^{+0.018}_0$	6 $^{+0.018}_0$	6 $^{+0.018}_0$	8 $^{+0.022}_0$
Phasing Pin (Reference) ^{*2}	$\phi 5(h8) \times 12$	$\phi 6(h8) \times 14$	$\phi 6(h8) \times 16$	$\phi 8(h8) \times 16$

Notes :

- Swing lever should be designed with its length according to performance curve.
- If the swing lever is not in accordance with the dimension shown above, performance may be degraded and damage can occur.

※1. The pin hole (ϕH) for determining the lever phase should be added, if necessary.

※2. Phasing pin is not included. Prepare it separately.

Accessory : Material Swing Lever for Taper Lock Lever

Corresponding Model No.

LZH 048 0 - T

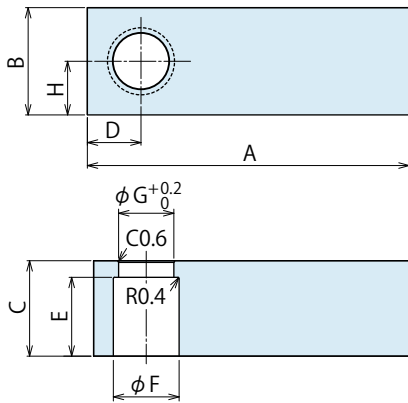
Size
(Refer to the table.)Design No.
(Revision Number)

Model No.	LZH0480-T	LZH0550-T	LZH0650-T	LZH0750-T
Corresponding Model No.	LHM0480 -C□-B□	LHM0550 -C□-B□	LHM0650 -C□-B□	LHM0750 -C□-B□
A	160	170	175	185
B	40	45	50	58
C	23	26	29	35
D	20	23	25	29
E	19	22	25	31
F	25	28	34	40
G	21	23.5	29	33
H	20	22.5	25	29

Notes :

1. Material : S50CH Surface Finishing : Alkaline Blackening
2. If necessary, the front end should be additionally machined and finished.
3. When determining the phase, refer to taper lock lever design dimensions for each model for the additional machining.

Wireless
Sensing Clamp

Accessory

Common
CautionsWireless Sensing
Swing Clamp

LHM

Wireless Sensing
Link Clamp

LKM

Wireless Sensing
Linear Cylinder

LLM

Receiver ·
Repeater

YWA

YWB

Cautions

Notes for Design

- 1) Check Specifications
 - Please use each product according to the specifications.
- 2) Radio Regulations
 - There are restrictions on countries where the product can be used according to radio regulations. Please follow the regulatory requirements of each country. (Ex.) LHM□-C□-B03 can be used in United States.

Regarding LHM□-C□-B02/B03

- At shipment, the signal transmission is in a disabled state, with the function stop nut attached. When enabling signal transmission, please remove the "function stop nut" before use.

Signal Transmission Function OFF Setting

- If it is absolutely necessary to operate this product in a country other than the available country, please disable the signal transmission function using the following settings.
By attaching the "function stop nut" and fixing the sensing rod to prevent movement, the signal transmission function can be stopped.

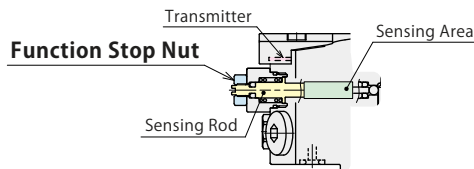

※ 5 Available Country : B01 does not support this function. (Please contact us separately if necessary.)

Notes for Circuit Design

- Please read "Notes on Hydraulic Cylinder Speed Control Unit" for proper hydraulic circuit design. Improper circuit design may lead to malfunctions and damages. (Refer to P.60)
- Ensure there is no possibility of supplying hydraulic pressure to the clamp port and the unclamp port simultaneously.

Swing lever should be designed to make the moment of inertia small.

- Large moment of inertia will degrade the lever's stopping accuracy and cause undue wear to the clamp. Additionally, the clamp may not function, depending on supplied hydraulic pressure and lever mounting position.
- Set the allowable operation time after the moment of inertia is calculated. Refer to "Allowable Swing Time Graph" and make sure to operate clamps within the allowable operation time.

Protect the exposed area of the piston rod when using on a welding fixture.

- If spatter attaches to the sliding surface it could lead to malfunction and fluid leakage.

When clamping on a sloped surface of the workpiece

- Make sure the clamping surface and the mounting surface of the clamp are parallel.

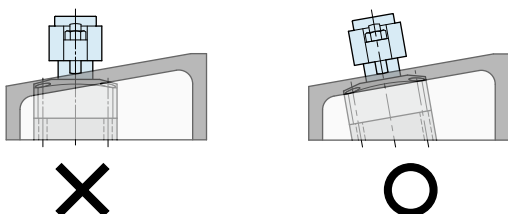

Installation of Sequence Valve (model BZS)

- Please contact us when the sequence valve model BZS0200 needs to be installed on LHM0650-C□-B□ or LHM0750-C□-B□. In some cases, installation may not be possible due to conditions and combinations of the products.

Notes for Usage

- 1) Do not cover the top surface of the sensing area with metal objects (chips, sludge, etc.). It may obstruct radio wave transmission. The cover is made of plastic material and should be protected from chips.

● Installation Notes

- 1) Check the Usable Fluid
 - Please use the appropriate fluid by referring to the Hydraulic Fluid List (P.59).
- 2) Swing Speed Adjustment
 - Adjust the speed following "Allowable Swing Time Graph". If the clamp operates too fast the parts will be worn out leading to premature damage and ultimately complete equipment failure.
 - Please make sure to release air from the circuit before adjusting speed. It will be difficult to adjust the speed accurately with air mixed in the circuit.
 - Turn the speed control valve gradually from the low-speed side (small flow) to the high-speed side (large flow) to adjust the speed.
 - When using multiple wireless sensing clamps / linear cylinders, provide an operating time difference of 100msec (0.1 sec.) or more. Simultaneous operation may cause radio interference, which may result in failure to receive unclamp signals properly. For adjusting the unclamp operation, please use a speed control valve.
- 3) Installation of the Product
 - When mounting the clamp, use hexagonal socket bolts as multiple bolt holes for mounting (with tensile strength of 12.9) and tighten them with the torque shown in the table below. Tightening with greater torque than recommended can dent the seating surface or break the bolt.

Model No.	Mounting Bolt Size	Tightening Torque (N·m)
LHM0480-C□-B□	M5×0.8	8.0
LHM0550-C□-B□	M6×1	14
LHM0650-C□-B□	M6×1	14
LHM0750-C□-B□	M8×1.25	33

- 4) Installation / Removal of the Swing Lever
 - Oil or debris on the tightened parts of the lever, taper sleeve or piston rod may cause the rod to loosen. Please clean them thoroughly before installation.
 - Tighten the tightening bolt of swing lever with the torque shown below. Tightening with greater torque than recommended can damage the bolt and lever tightening function.

LHM Standard : Taper Lock Lever

Model No.	Thread Size	Tightening Torque (N·m)
LHM0480-C□-B□	M20×1.5	54 ~ 65
LHM0550-C□-B□	M22×1.5	84 ~ 100
LHM0650-C□-B□	M27×1.5	120 ~ 145
LHM0750-C□-B□	M30×1.5	175 ~ 210

- In case of Using LHM Standard (Taper Lock Lever)
If the piston rod is subjected to excessive torque or shock, the rod or the internal mechanism may be damaged. Observe the following points to prevent such shock.

Installation Procedure

- ① With a clamp positioned to a jig, determine the lever position, and tighten the nut for fixing the lever (temporal tightening).
- ② Remove the clamp from the jig, fix the lever with a machine vise etc., and tighten the nut.
- ③ If tightening the nut with the clamp positioned to the jig, use a wrench to the hexagon part of piston rod, or fix the lever with a spanner. It is best to bring the lever to the middle of the swing stroke before tightening the nut.

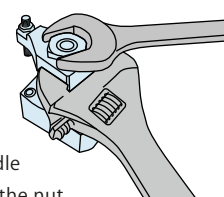
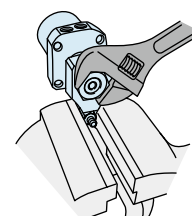

Removal Procedure

- ① While the clamp is on the jig or vise, use a hex wrench to bring the lever to the middle of the swing stroke and then loosen the nut.
- ② Loosen the nut after securing the lever two or three turns then remove the lever with a puller without any rotational torque applied on the piston rod.

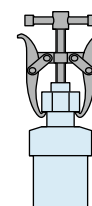

- 5) Initial Connection Settings for the Receiver
During setup, it is necessary to perform the initial connection settings between the clamp and the receiver. (For detailed instructions, please refer to the instruction manual of receiver YWA.)
- 6) Cautions for Repeater Installation
The maximum distance between the clamp and the receiver is 5 meters. Check the radio wave strength displayed on the receiver and consider the location of the repeater. (Recommended Threshold : -85dBm)
It is recommended to install the repeater in locations such as the upper part inside the processing machine, where it is less likely to be exposed to coolant or chips.

Guidelines for Repeater Installation

- ① When the receiver cannot be installed at a height of 2 meters or more.
- ② When there is a radio wave obstruction between the clamp and the receiver.
- ③ When the clamp and the receiver are more than 3 meters apart.

※ Please refer to P.59 for common cautions.

• Installation Notes • Hydraulic Fluid List • Notes on Hydraulic Cylinder Speed Control Circuit
• Notes on Handling • Maintenance/Inspection • Warranty

Speed Control Valve (For Low Pressure)

Directly Mounted to Clamps / Cylinders

Speed Control Valve (model BZL) attaches directly to KOSMEK hydraulic clamp with piping method: type C.

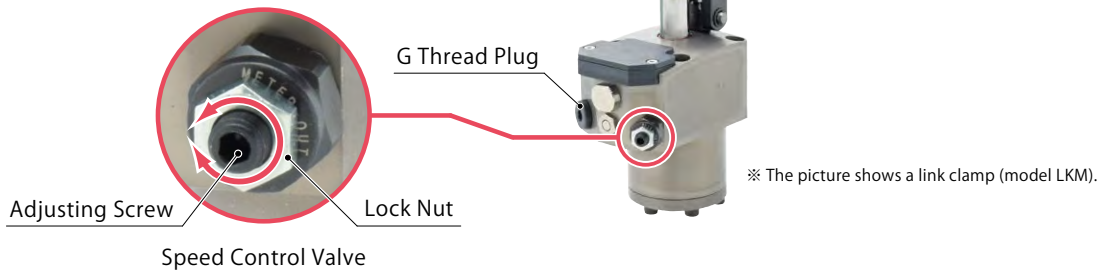

Action Description

Control the flow with a wrench. Able to change the operating speed of a clamp/cylinder individually.

Able to release the air in the circuit by loosening the Speed Control Valve.

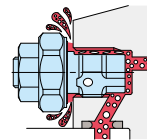
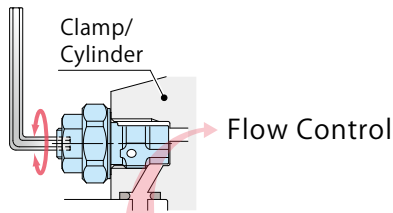

Model No. Indication (Speed Control Valve for Low Pressure)

BZL 0 10 1 - B

1 2 3

1 G Thread Size

10 : Thread Part G1/8A Thread

20 : Thread Part G1/4A Thread

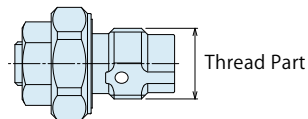

2 Design No.

1 : Revision Number

3 Control Method

B : Meter-out (Recommended^{※1})

A : Meter-in

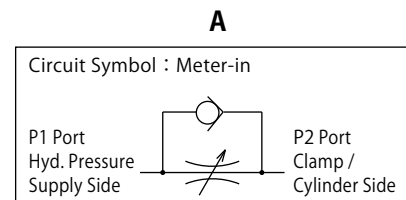
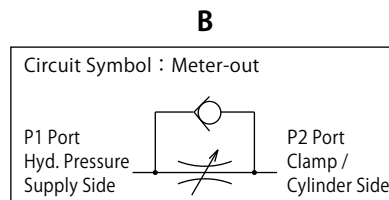

※1. Flow control circuit for double-acting clamp/cylinder should have meter-out circuits for both the clamp and unclamp sides (except model LKE/TLA/TMA). Meter-in circuits can be adversely affected by any air in the system.

Specifications

Model No.	BZL0101-B	BZL0201-B	BZL0101-A	BZL0201-A	
Max. Operating Pressure	MPa	7			
Withstanding Pressure	MPa	10.5			
Control Method	Meter-out		Meter-in		
G Thread Size	G1/8A	G1/4A	G1/8A	G1/4A	
Cracking Pressure	MPa	0.12		0.04	
Max. Passage Area	mm ²	2.6	5.0	2.6	5.0
Usable Fluid	°C	0 ~ 70			
Operating Temperature	General Hydraulic Oil Equivalent to ISO-VG-32				
Tightening Torque for Main Body	N·m	10	25	10	25
Weight	g	12	26	12	26

- Notes : 1. It must be mounted with recommended torque. Because of the structure of the metal seal, if mounting torque is insufficient, the flow control valve may not be able to adjust the flow rate.
2. Do not attach a used BZL to other clamps/cylinders.
Flow control will not be made because the bottom depth difference of G thread makes metal seal insufficient.

Applicable Products

Model No.	LHM (Double Action) Swing Clamp	LKM (Double Action) Link Clamp	LLM (Double Action) Linear Cylinder
BZL0101-B	LHM0480-C□-B□ LHM0550-C□-B□	LKM0480-C□-B□ LKM0550-C□-B□	LLM0480-C□□-B□-□ LLM0550-C□□-B□-□
BZL0101-A	(LHM0480-C□-B□) (LHM0550-C□-B□)	(LKM0480-C□-B□) (LKM0550-C□-B□)	(LLM0480-C□□-B□-□) (LLM0550-C□□-B□-□)
BZL0201-B	LHM0650-C□-B□ LHM0750-C□-B□	LKM0650-C□-B□ LKM0750-C□-B□	
BZL0201-A	(LHM0650-C□-B□) (LHM0750-C□-B□)	(LKM0650-C□-B□) (LKM0750-C□-B□)	

● Flow Rate Graph < Hydraulic Fluids ISO-VG32 (25 ~ 35°C) >

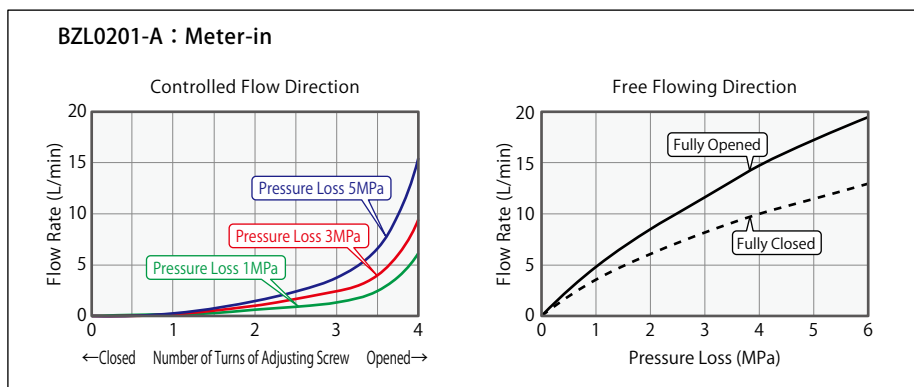
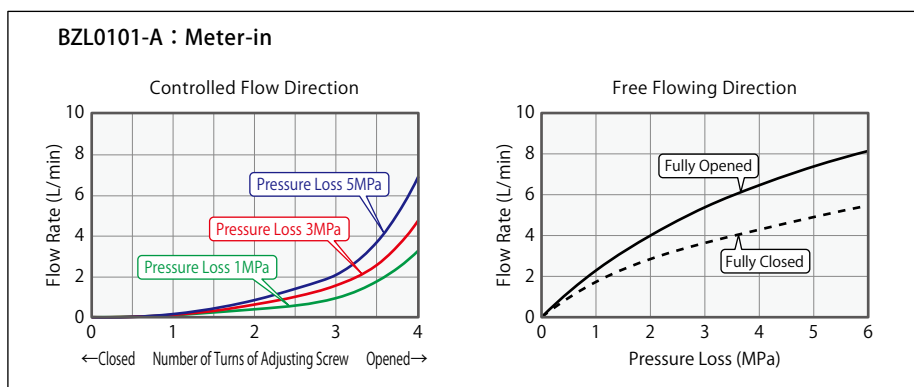
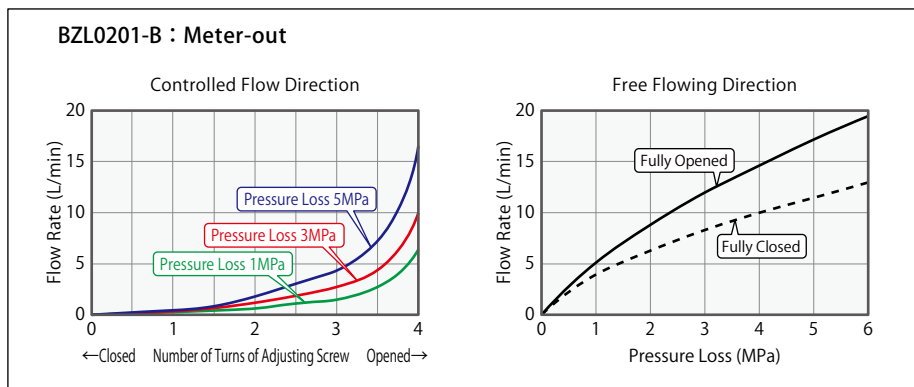
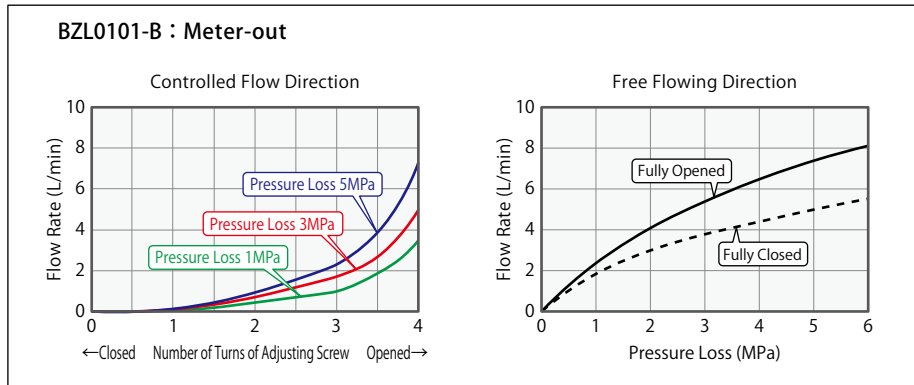

External Dimensions

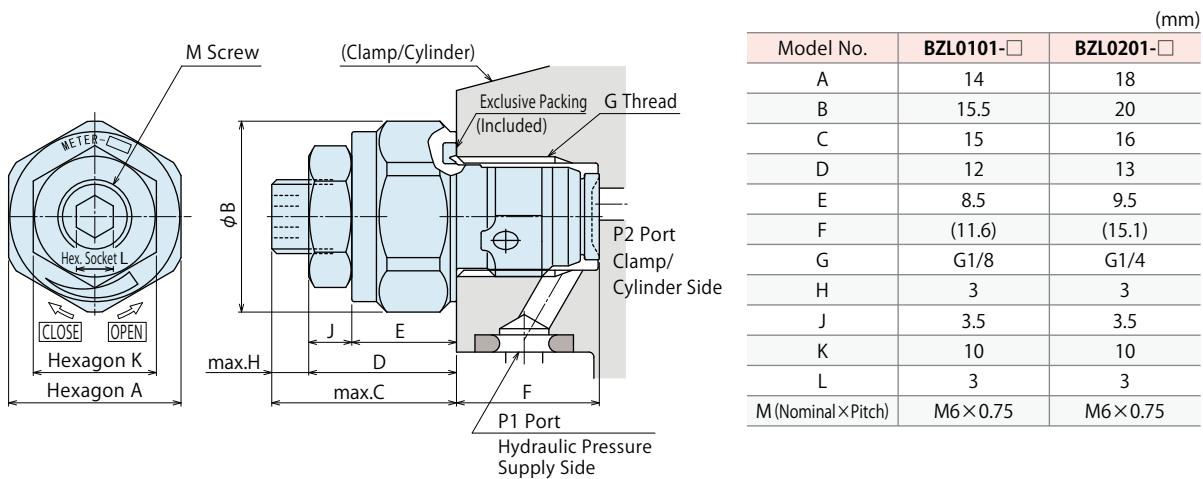

Notes

1. Please read "Notes on Hydraulic Cylinder Speed Control Unit" for proper hydraulic circuit design. Improper circuit design may lead to malfunctions and damages. (Refer to P.60)
2. It is dangerous to release the air under high pressure. It must be done under lower pressure. (For reference : the minimum operating range of the product within the circuit.)
3. Flow control circuit for double-acting clamp/cylinder should have meter-out circuits for both the clamp and unclamp sides (except model LKE/TLA/TMA). Meter-in circuits can be adversely affected by any air in the system.

 Wireless
 Sensing Clamp

Accessory

 Common
 Cautions

Control Valve

BZL

● Cautions

● Installation Notes (For Hydraulic Series)

- 1) Check the Usable Fluid
 - Please use the appropriate fluid by referring to the Hydraulic Fluid List.
- 2) Procedure before Piping
 - The pipeline, piping connector and fixture circuits should be cleaned by thorough flushing.
 - The dust and cutting chips in the circuit may lead to fluid leakage and malfunction.
 - There is no filter provided with Kosmek's product except for a part of valves which prevents foreign materials and contaminants from getting into the circuit.
- 3) Applying Sealing Tape
 - Wrap with tape 1 to 2 times following the screw direction.
 - Pieces of the sealing tape can lead to oil leakage and malfunction.
 - Please implement piping construction in a clear environment to prevent anything getting in products.
- 4) Air Bleeding of the Hydraulic Circuit
 - If the hydraulic circuit has excessive air, the action time may become very long. If air enters the circuit after connecting the hydraulic port or under the condition of no air in the oil tank, please perform the following steps.
 - ① Reduce hydraulic pressure to less than 2MPa.
 - ② Loosen the cap nut of pipe fitting closest to the clamp by one full turn.
 - ③ Shake the pipeline to loosen the outlet of pipe fitting.
Hydraulic fluid mixed with air comes out.

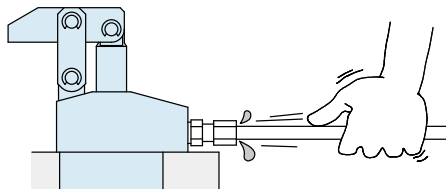

- ④ Tighten the cap nut after bleeding.
- ⑤ It is more effective to release air at the highest point inside the circuit or at the end of the circuit.
(Set an air bleeding valve at the highest point inside the circuit.)

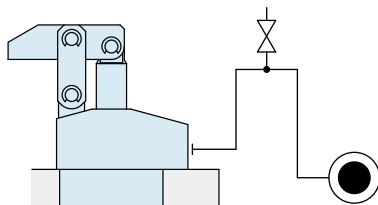

5) Checking Looseness and Retightening

- At the beginning of the machine installation, the bolt and nut may be tightened lightly. Check the looseness and re-tighten as required.

● Hydraulic Fluid List

Maker	ISO Viscosity Grade ISO-VG-32	
	Anti-Wear Hydraulic Oil	Multi-Purpose Hydraulic Oil
Showa Shell Sekiyu	Tellus S2 M 32	Morlina S2 B 32
Idemitsu Kosan	Daphne Hydraulic Fluid 32	Daphne Super Multi Oil 32
JX Nippon Oil & Energy	Super Hyrando 32	Super Mulpus DX 32
Cosmo Oil	Cosmo Hydro AW32	Cosmo New Mighty Super 32
ExxonMobil	Mobil DTE 24	Mobil DTE 24 Light
Matsumura Oil	Hydol AW-32	
Castrol	Hyspin AWS 32	

Note : Please contact manufacturers when customers require products in the list above.

● Notes on Hydraulic Cylinder Speed Control Unit

Please pay attention to the cautions below. Design the hydraulic circuit for controlling the action speed of hydraulic cylinder. Improper circuit design may lead to malfunctions and damages. Please review the circuit design in advance.

● Flow Control Circuit for Single Acting Cylinder
For spring return single-acting cylinders, restricting flow during release can extremely slow down or disrupt release action. The preferred method is to control the flow during the lock action using a valve that has free-flow in the release direction. It is also preferred to provide a flow control valve at each actuator.

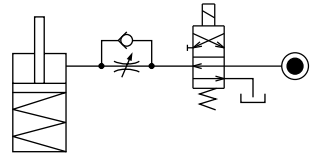

Accelerated clamping speed by excessive hydraulic flow to the cylinder may sustain damage. In this case add flow control to regulate flow. (Please add flow control to release flow if the lever weight is put on at the time of release action when using swing clamps.)

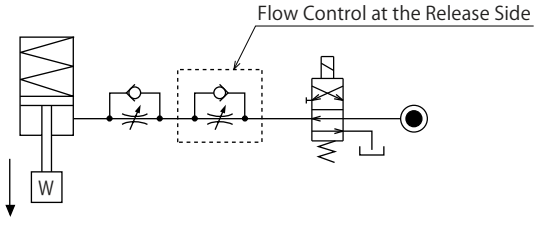

● Flow Control Circuit for Double Acting Cylinder
Flow control circuit for double-acting cylinder (except LKE/LSE/TLA/TLB/TMA/TLV/TMV/TTA) should have meter-out circuits for both the lock and release sides. Meter-in control can have adverse effect by presence of air in the system. However, in the case of controlling LKE, LSE, TLA, TLB, TMA, TLV, TMV, TTA both lock side and release side should be meter-in circuit. If meter-out circuit is used for TLA, TLB, TMA, TLV, TMV, TTA, abnormal high pressure is created, which causes oil leakage and damage.

【Meter-out Circuit】 (Except LKE/LSE/TLA/TLB/TMA/TLV/TMV/TTA)

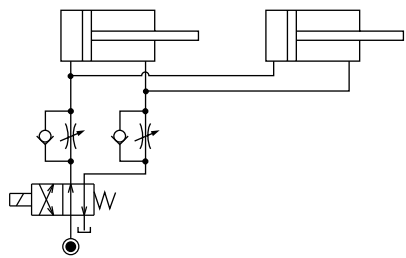

【Meter-in Circuit】 (LKE/LSE/TLA/TLB/TMA/TLV/TMV/TTA must be controlled with meter-in.)

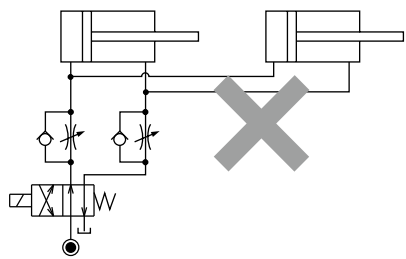

In the case of meter-out circuit, the hydraulic circuit should be designed with the following points.

- ① Single acting components should not be used in the same flow control circuit as the double acting components. The release action of the single acting cylinders may become erratic or very slow.

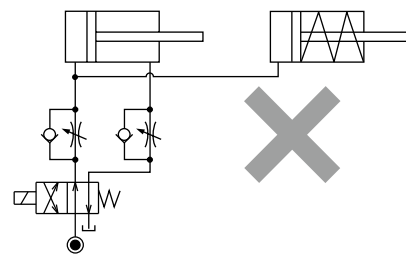

Refer to the following circuit when both the single acting cylinder and double acting cylinder are used together.
○ Separate the control circuit.

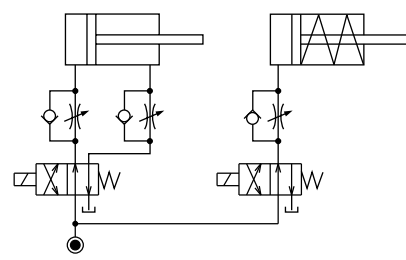

- Reduce the influence of double acting cylinder control unit. However, due to the back pressure in tank line, single action cylinder is activated after double action cylinder works.

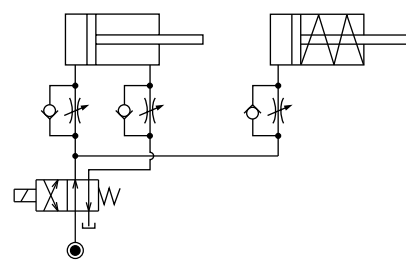

- ② In the case of meter-out circuit, the inner circuit pressure may increase during the cylinder action because of the fluid supply. The increase of the inner circuit pressure can be prevented by reducing the supplied fluid beforehand via the flow control valve. Especially when using sequence valve or pressure switches for clamping detection. If the back pressure is more than the set pressure then the system will not work as it is designed to.

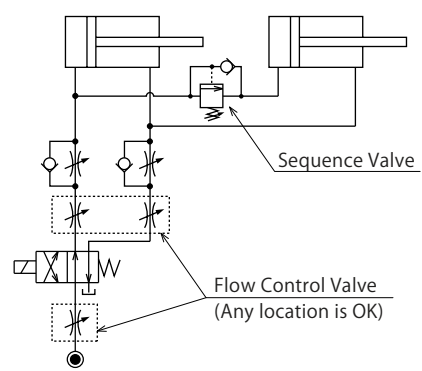

ⓘ Cautions

● Notes on Handling

- 1) It should be operated by qualified personnel.
 - Machines and devices with hydraulic and pneumatic products should be operated and maintained by qualified personnel.
- 2) Do not operate or remove the product unless the safety protocols are ensured.
 - ① Machines and devices can only be inspected or prepared when it is confirmed that the safety devices are in place.
 - ② Before the product is removed, make sure that the above-mentioned safety devices are in place. Shut off the pressure and power source, and make sure no pressure exists in the air and hydraulic circuits.
 - ③ After stopping the product, do not remove until the temperature drops.
 - ④ Make sure there is no trouble/issue in the bolts and respective parts before restarting a machine or device.
- 3) Do not touch a clamp (cylinder) while it is working. Otherwise, your hands may be injured due to clinching.

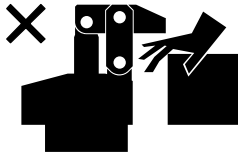

- 4) Do not disassemble or modify.
 - If the equipment is taken apart or modified, the warranty will be voided even within the warranty period.

● Maintenance and Inspection

- 1) Removal of the Machine and Shut-off of Pressure Source
 - Before the machine is removed, make sure that safety devices and preventive devices are in place. Shut off the pressure and power source, and make sure no pressure exists in the air and hydraulic circuits.
 - Make sure there is no abnormality in the bolts and respective parts before restarting.
- 2) Regularly clean the area around the piston rod.
 - If it is used when the surface is contaminated with dirt, it may lead to packing seal damage, malfunctioning and fluid leakage.

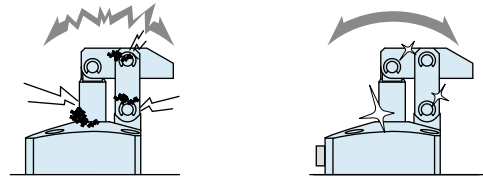

- 3) If disconnecting by couplers, air bleeding should be carried out on a regular basis to avoid air mixed in the circuit.
- 4) Regularly tighten pipe line, mounting bolt, nut, snap ring, cylinder and others to ensure proper use.
- 5) Make sure the hydraulic fluid has not deteriorated.
- 6) Make sure there is a smooth action without an irregular noise.
 - Especially when it is restarted after left unused for a long period, make sure it can be operated correctly.
- 7) The products should be stored in the cool and dark place without direct sunshine or moisture.
- 8) Please contact us for overhaul and repair.

● Warranty

1) Warranty Period

- The product warranty period is 18 months from shipment from our factory or 12 months from initial use, whichever is earlier.

2) Warranty Scope

- If the product is damaged or malfunctions during the warranty period due to faulty design, materials or workmanship, we will replace or repair the defective part at our expense.
Defects or failures caused by the following are not covered.

- ① If the stipulated maintenance and inspection are not carried out.
- ② If the product is used while it is not suitable for use based on the operator's judgment, resulting in defect.
- ③ If it is used or operated in an inappropriate way by the operator. (Including damage caused by the misconduct of the third party.)
- ④ If the defect is caused by reasons other than our responsibility.
- ⑤ If repair or modifications are carried out by anyone other than Kosmek, or without our approval and confirmation, it will void warranty.
- ⑥ Other caused by natural disasters or calamities not attributable to our company.
- ⑦ Parts or replacement expenses due to parts consumption and deterioration. (Such as rubber, plastic, seal material and some electric components.)

Damages excluding from direct result of a product defect shall be excluded from the warranty.



KOSMEK LTD.

▶ <https://www.kosmek.com/>

HEAD OFFICE 1-5, 2-chome, Murotani, Nishi-ku, Kobe-city, Hyogo, Japan 651-2241
TEL.+81-78-991-5162 FAX.+81-78-991-8787

United States of America SUBSIDIARY	KOSMEK (USA) LTD. 650 Springer Drive, Lombard, IL 60148 USA TEL. +1-630-620-7650 FAX. +1-630-620-9015
MEXICO BRANCH OFFICE	KOSMEK USA MEXICO BRANCH OFFICE Av. Loma Pinal de Amoles 320-piso PH oficina 504 interior 13, Vista Dorada, 76060 Santiago de Querétaro, Qro. Mexico TEL. +52-442-851-1377
EUROPE SUBSIDIARY	KOSMEK EUROPE GmbH Schleppeplatz 2 9020 Klagenfurt am Wörthersee Austria TEL. +43-463-287587 FAX. +43-463-287587-20
CHINA SUBSIDIARY	KOSMEK (CHINA) LTD. Room601, RIVERSIDE PYRAMID No.55, Lane21, Pusan Rd, Pudong Shanghai 200125, China TEL. +86-21-54253000
INDIA BRANCH	KOSMEK LTD. - INDIA 4A/Old No:649, Ground Floor, 4th D cross, MM Layout, Kavalbyrasandra, RT Nagar, Bangalore -560032 India TEL.+91-9880561695
THAILAND REPRESENTATIVE OFFICE	KOSMEK Thailand Representation Office No.139, Blue Chips Building, 4th Floor, Room No.422, Soi Sukhumvit 63 (Thong Lor 10), Sukhumvit Road, Khlong Tan Nuea, Wattana, Bangkok 10110, Thailand TEL. +66(0)2-059-2010

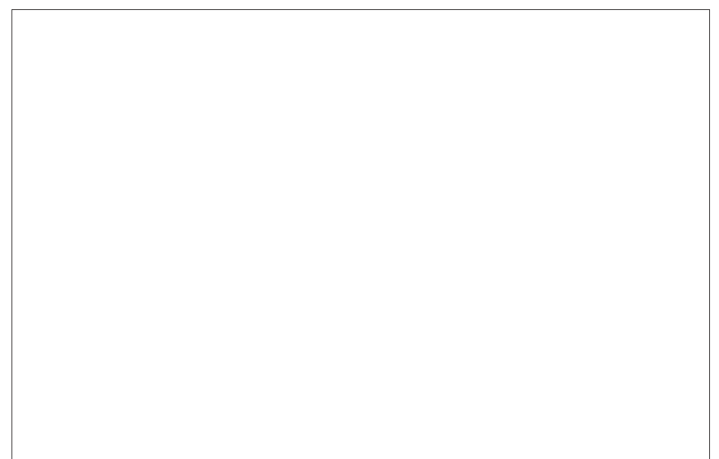

- For Further Information on Unlisted Specifications and Sizes, Please call us.
- Specifications in this Leaflet are Subject to Change without Notice.



JQA-QMA10823
KOSMEK HEAD OFFICE