

New Mold and Productivity Improvement

Diecast Mold Cylinder Series

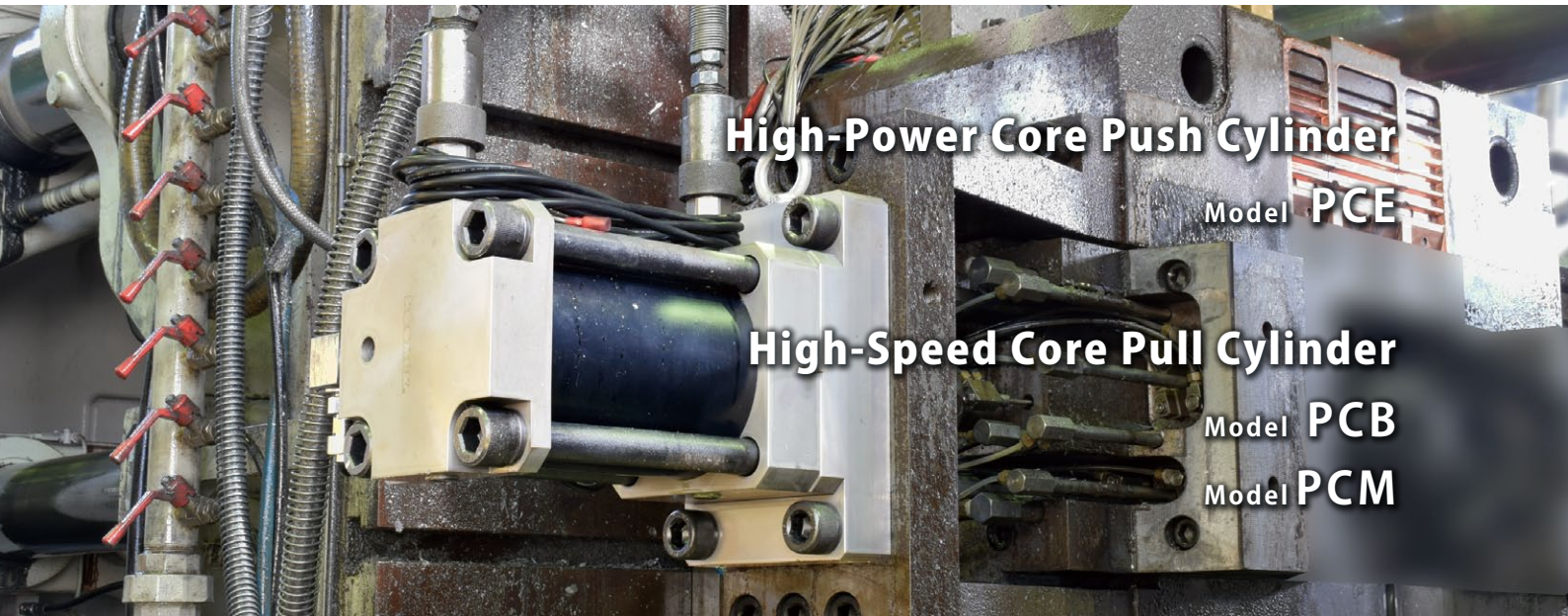

High-Speed Core Pull Cylinder

Model **PCE**

High-Speed Core Pull Cylinder

Model **PCB**

Model **PCM**

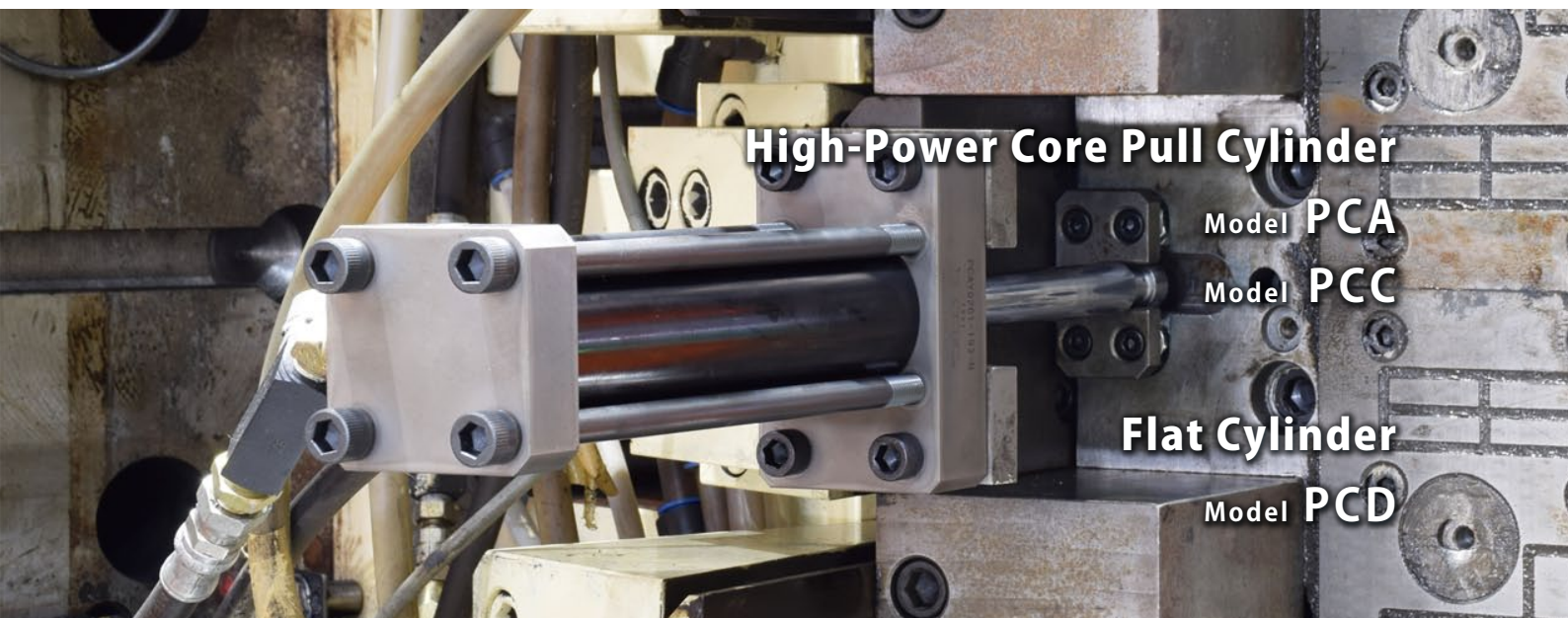

High-Speed Core Pull Cylinder

Model **PCA**

Model **PCC**

Flat Cylinder

Model **PCD**

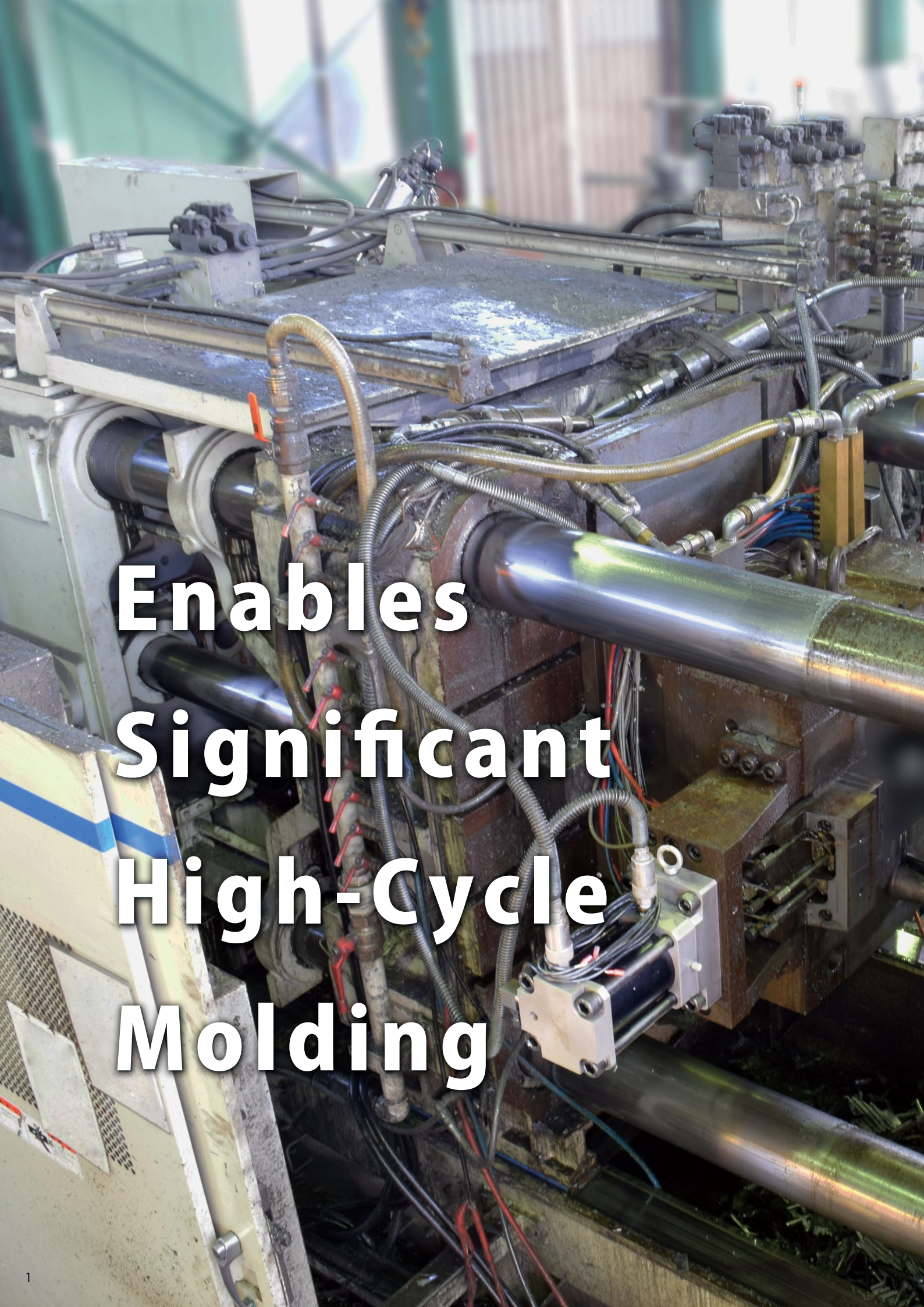

**Enables
Significant
High-Cycle
Molding**

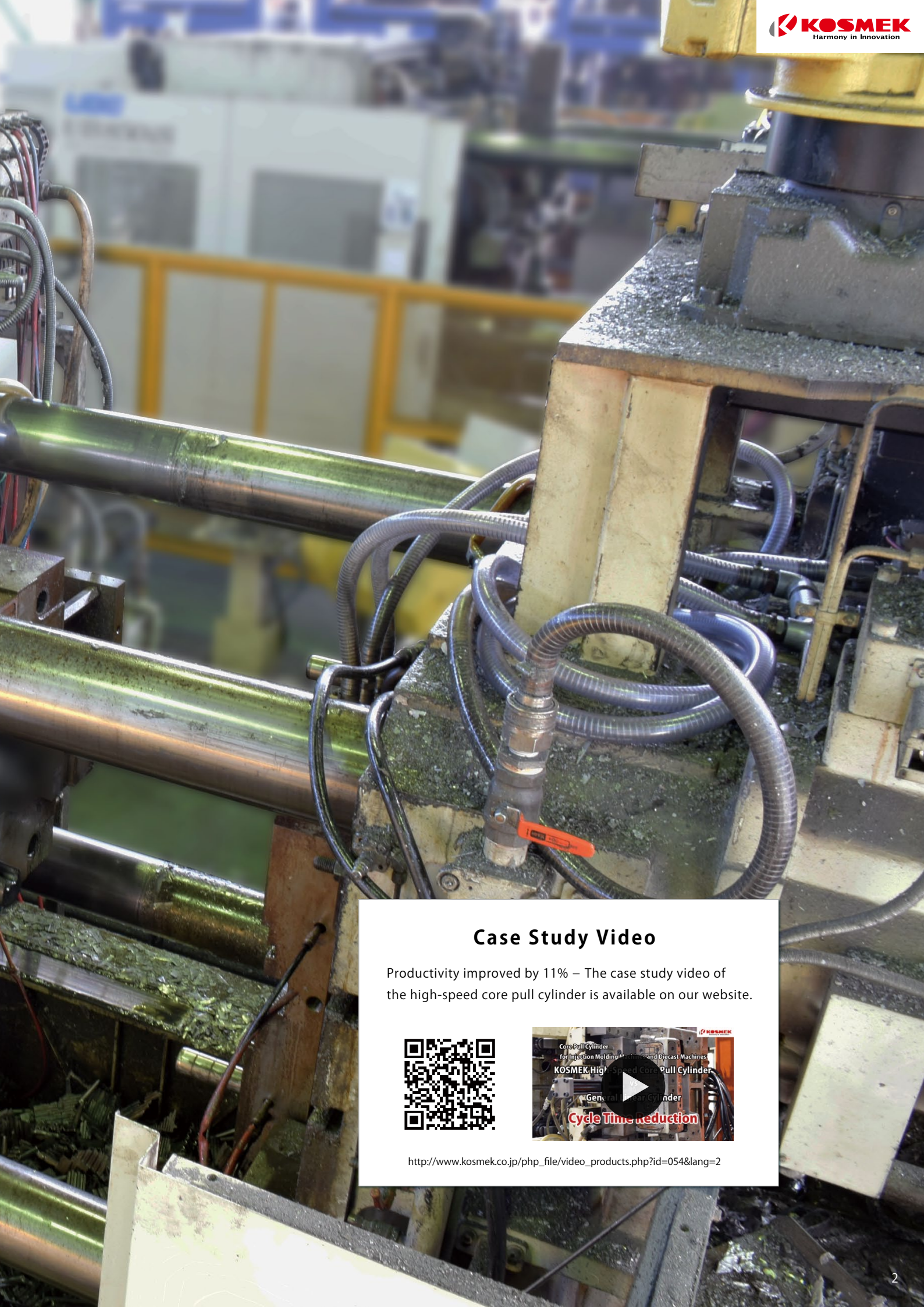

Case Study Video

Productivity improved by 11% – The case study video of the high-speed core pull cylinder is available on our website.



http://www.kosmek.co.jp/php_file/video_products.php?id=054&lang=2

Diecast Mold Cylinder Series

1 P.07

High-Power Core Push Cylinder

Model PCE

With built-in mechanical lock, the cylinder is designed for tunnel core which enables it to withstand the casting pressure.



2 P.15

High-Speed Core Pull Cylinder

Model PCB

Interchangeable with a general core cylinder. Drastically reduces cycle time.

Additional line-up: Larger models (cylinder inner diameter $\phi 200$, $\phi 250$ mm), Longer stroke models (applicable stroke 40 ~ 500mm).



3 P.25

High-Speed Core Pull Cylinder Compact Model

Model PCM

Compact model of High-Speed Core Pull Cylinder
Line-up: Cylinder inner diameter $\phi 40$ and $\phi 50$ mm.



4 P.33

High-Power Core Pull Cylinder

Model PCA/PCC

High-power with mechanical lock enables you to select 2~3 sizes smaller cylinder, resulting in downsizing of mold. Also, it drastically reduces cycle time.

Additional line-up: Larger models (cylinder inner diameter $\phi 200$, $\phi 250$ mm), Longer stroke models (applicable stroke 40 ~ 500mm).



P.45

Limit Switch

Limit Switch for Action Confirmation

Compact model and relay box model are newly added to the line-up.

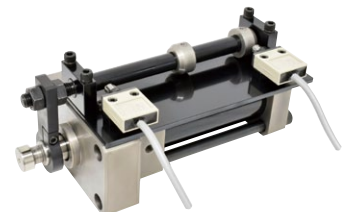

P.50

Accessory for Limit Switch

LS Arm to connect the limit switch and the cylinder.

P.52

Tapped Hole Position for Hanging Bolt

Overall View of Kosmek Products

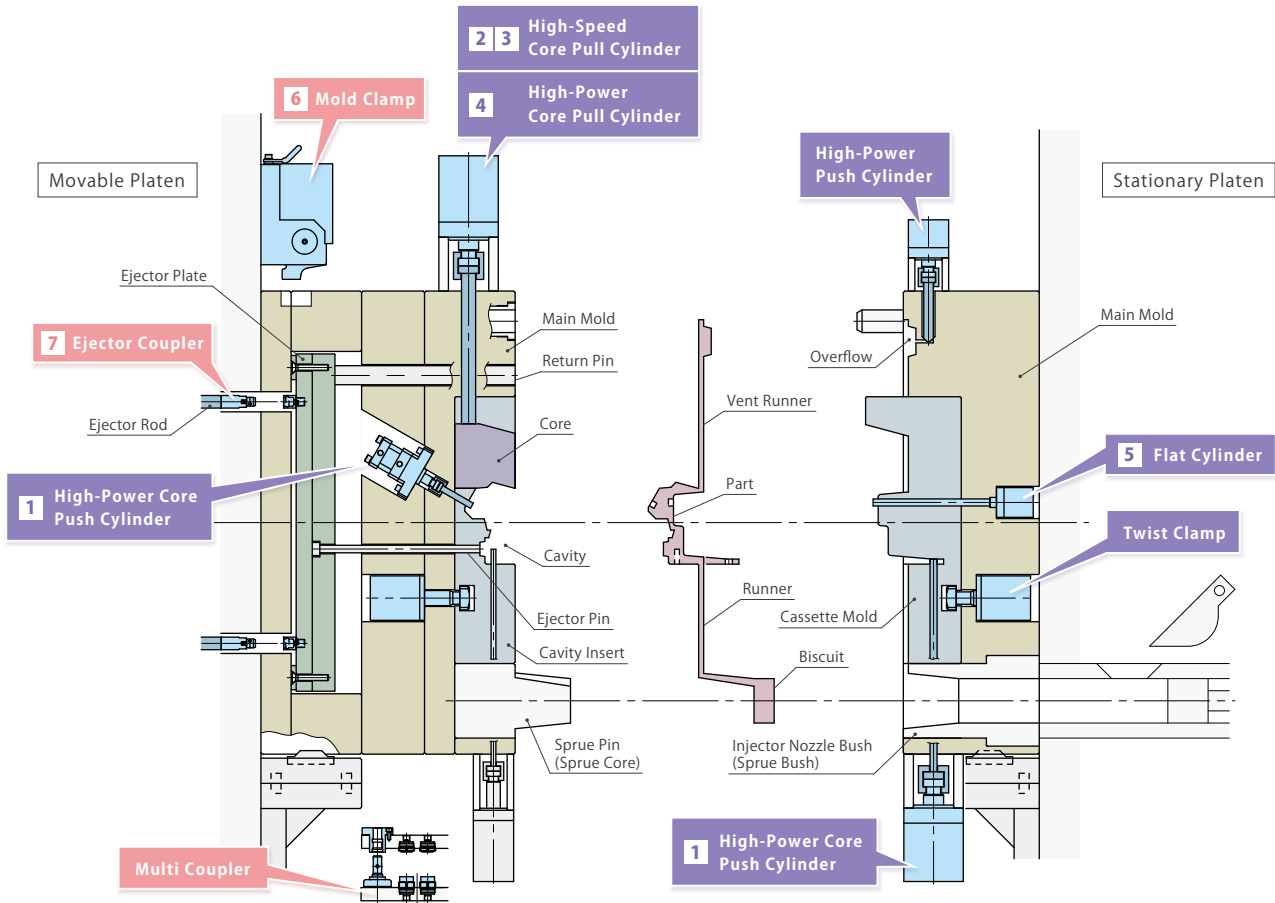

5 P.53

Flat Cylinder

Model PCD

Compact Body Designed for Built-in Mold Cylinder
Suitable for partial pressurization, and opening/closing a vent valve.

Switch option and magnetostrictive sensor option have been newly added to the line-up.



P.65

Common Accessories

Joint and Coupling are available to be installed to the rod end.

P.69

Cautions

Mold Change System for Diecast Machine

6

Diecast Mold Clamp

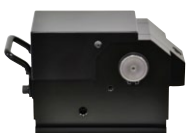

7

Ejector Coupler



KDCS Complete Catalog



For further information of other products,
please order the complete catalog from our website.



Scan the QR code for
Catalog Request and Inquiry

http://www.kosmek.co.jp/php_file/inquiry.php?lang=2

Kosmek Core Cylinder Comparison Table

	Feature	Applicable Size (Cylinder Inner Diameter) (mm)	Applicable Stroke (mm)
<p>P.07</p> <p>High-Power Core Push Cylinder</p>  <p>Model PCE</p>	PUSH	ϕ 40 ϕ 63 ϕ 80 ϕ 100 ϕ 125	30 ~ 150 ※ It depends on size. ※ In 1mm increments.
<p>P.15</p> <p>High-Speed Core Pull Cylinder</p>  <p>Model PCB</p>	PULL	ϕ 63 ϕ 200 ϕ 80 ϕ 250 ϕ 100 ϕ 125 ϕ 160	40 ~ 500 ※ It depends on size. ※ In 5mm increments.
<p>P.25</p> <p>High-Speed Core Pull Cylinder Compact Model</p>  <p>Model PCM</p>	PULL	ϕ 40 ϕ 50	40 ~ 200 ※ In 5mm increments.
<p>P.33</p> <p>High-Power Core Pull Cylinder High-Speed Model</p>  <p>Model PCA</p>	PULL	ϕ 63 ϕ 200 ϕ 80 ϕ 250 ϕ 100 ϕ 125 ϕ 160	40 ~ 500 ※ It depends on size. ※ In 5mm increments.
<p>P.33</p> <p>High-Power Core Pull Cylinder Standard Model</p>  <p>Model PCC</p>	PULL	ϕ 63 ϕ 80 ϕ 100 ϕ 125 ϕ 160	40 ~ 500 ※ It depends on size. ※ In 5mm increments.

Ratio When Compared To Same-size General Linear Cylinder
 *100% = Equivalent to a general cylinder

Pushing Force		Pulling Force		Cylinder Capacity (In case of Stroke = 100mm)		
Boosting Force	Idle Force	Pulling Force	Idle Force	Push side	Pull side	
250% <small>(Push End ~ 5mm) ※ PCE0401:3mm</small>	100% <small>(5mm ~ Pull End)</small>	100%		100%	100%	Model PCE
40%		100% <small>(Push End ~ 20mm)</small>	20% <small>(20mm ~ Pull End)</small>	50%	40%	Model PCB
50%		100% or more <small>(Push End ~ 20mm)</small>	40% <small>(20mm ~ Pull End)</small>	55%	55%	Model PCM
40%		180% <small>(Push End ~ 20mm)</small>	20% <small>(20mm ~ Pull End)</small>	50%	50%	Model PCA
100%		180% <small>(Push End ~ 20mm)</small>	100% <small>(20mm ~ Pull End)</small>	100%	100%	Model PCC

For Diecast Systems

High-Power Core Push Cylinder

Model PCE

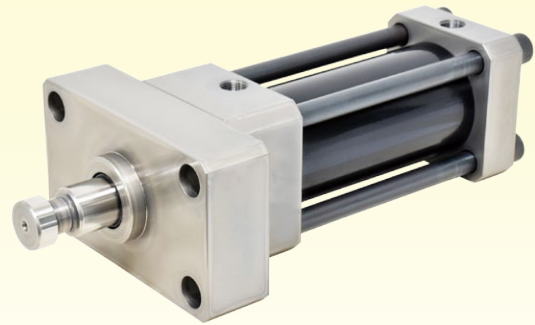

Mechanical locking withstands the casting pressure.

Best for stationary mold core and tunnel core.

Common Problems of stationary mold core and tunnel core.

Cotter cannot be used for stationary mold core or tunnel core. Therefore, it requires a core cylinder to withstand the casting pressure by itself.

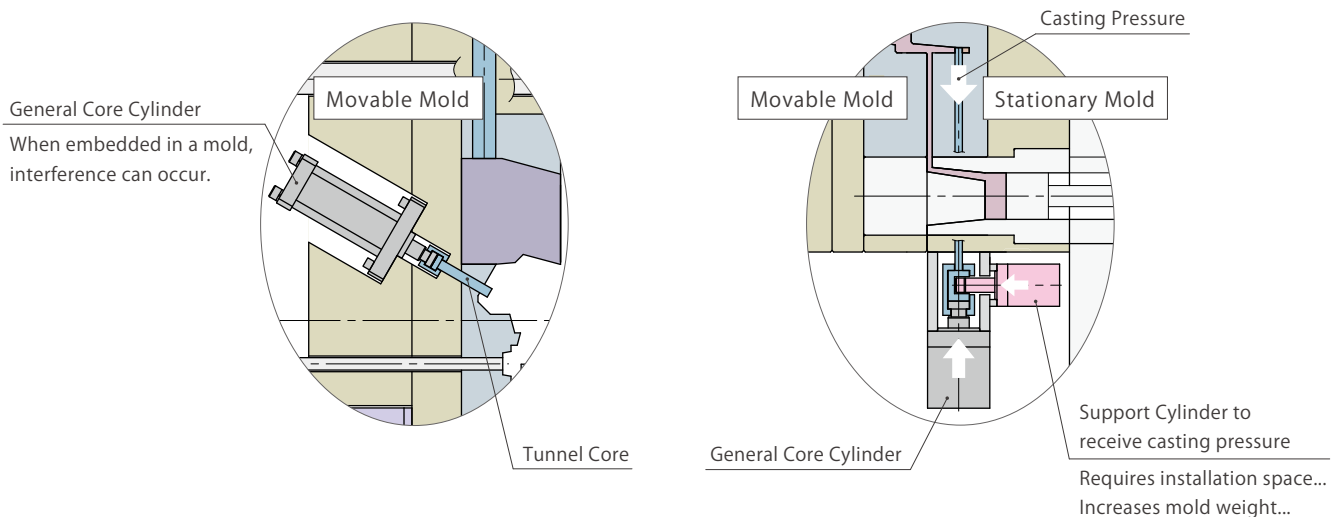

**Compared to general cylinder,
Kosmek High-Power Core Push Cylinder
withstands load of 250%.**

Avoid Interference

Minimize Core Cylinder

General Linear Cylinder

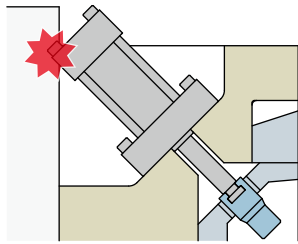

Interference

Requires a large cylinder to withstand casting pressure, but the mold thickness is limited, resulting in interference.

High-Power Core Push Cylinder

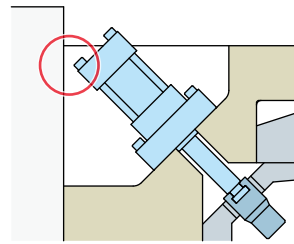

No Interference

250% of boosting force allows cylinder size to be minimized.

Reduce Cycle Time

Increase Operating Speed

General Linear Cylinder

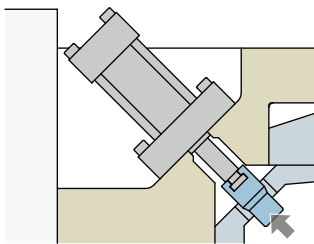

Operating Speed : LOW

Larger cylinder needed to withstand casting pressure, resulting in low operating speed.

High-Power Core Push Cylinder

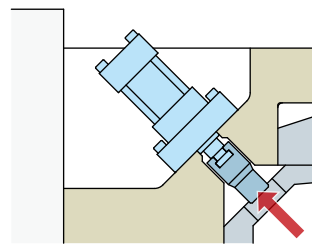

Operating Speed : HIGH

More compact cylinder enables an increased operating speed thereby reducing production cycle time.

Simplify Mold Design

Eliminate Support Cylinder

General Linear Cylinder

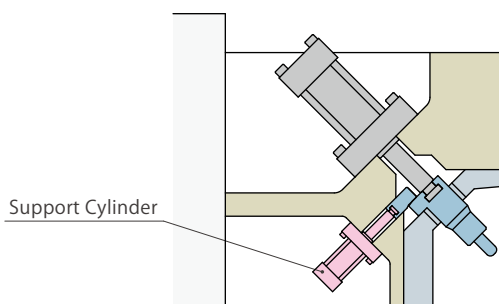

Support Cylinder Required

Core cylinder cannot withstand casting pressure on its own, so a support cylinder must be installed.

High-Power Core Push Cylinder

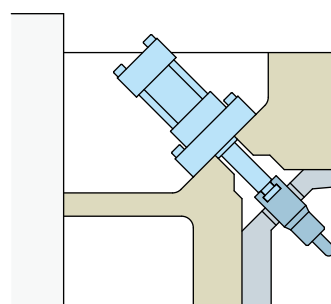

Support Cylinder Not Required

With 250% of boosting force, there is no need for a support cylinder which simplifies the mold design.

High-Power
Core Push Cylinder

High-Speed
Core Pull Cylinder

High-Speed
Core Pull Cylinder
Compact Model

High-Power
Core Pull Cylinder

Flat Cylinder

Simplify Core Control

Complicated Control Not Required

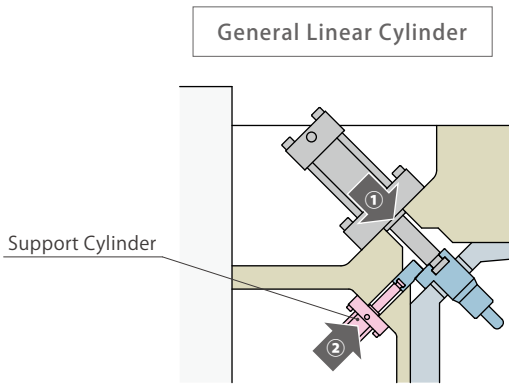

2-step Operation Required

2-step operation of core cylinder and support cylinder requires a complicated sequence, resulting in a longer cycle time.

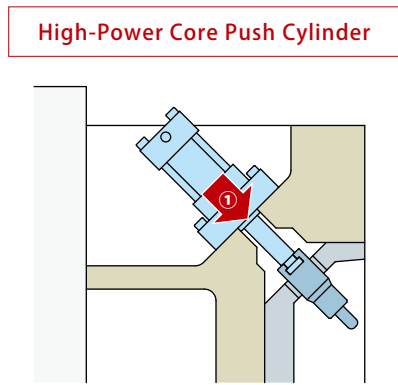

Simple Operation of Core Cylinder Only

Simple sequence is possible without using a support cylinder, reducing cycle time.

High-Power Core Push Cylinder Withstands Casting Pressure with Mechanical Lock !

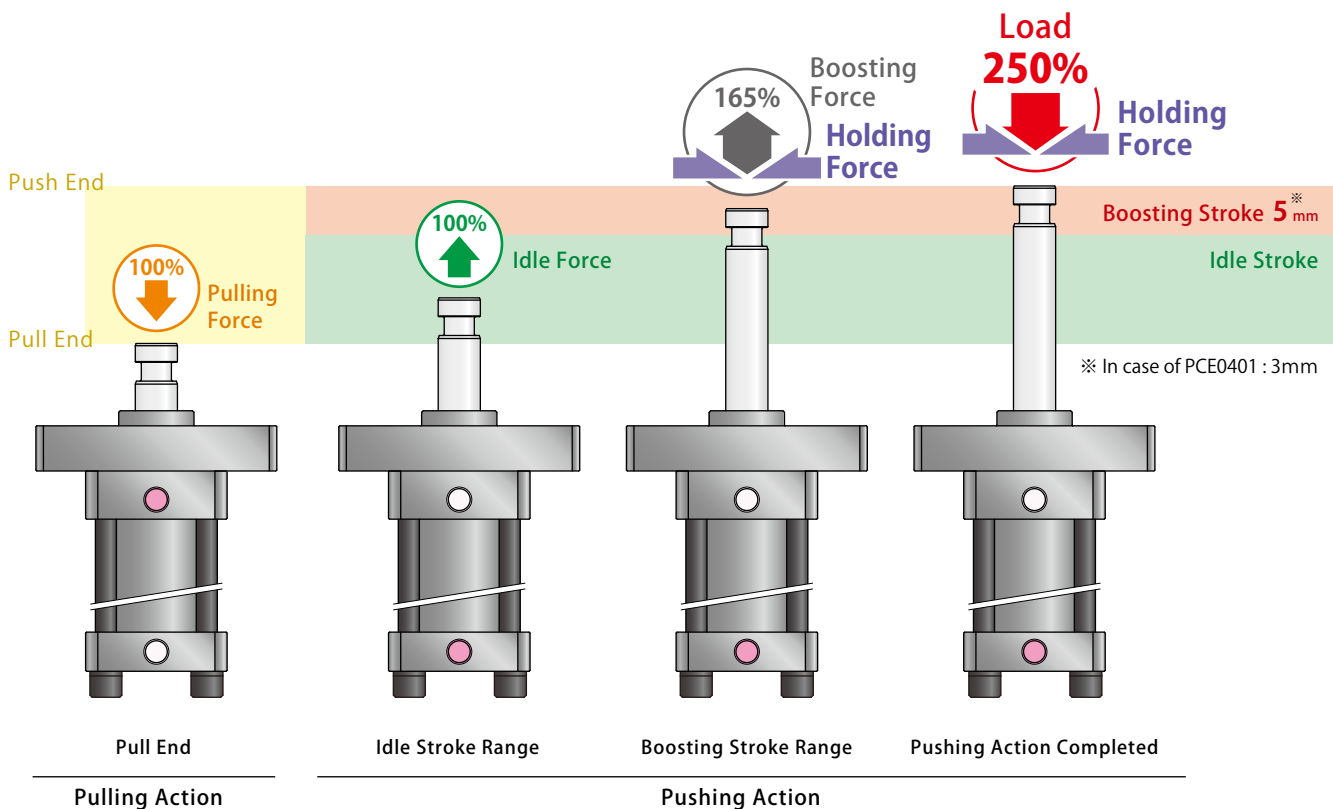

Mechanical Lock Prevents Core Return

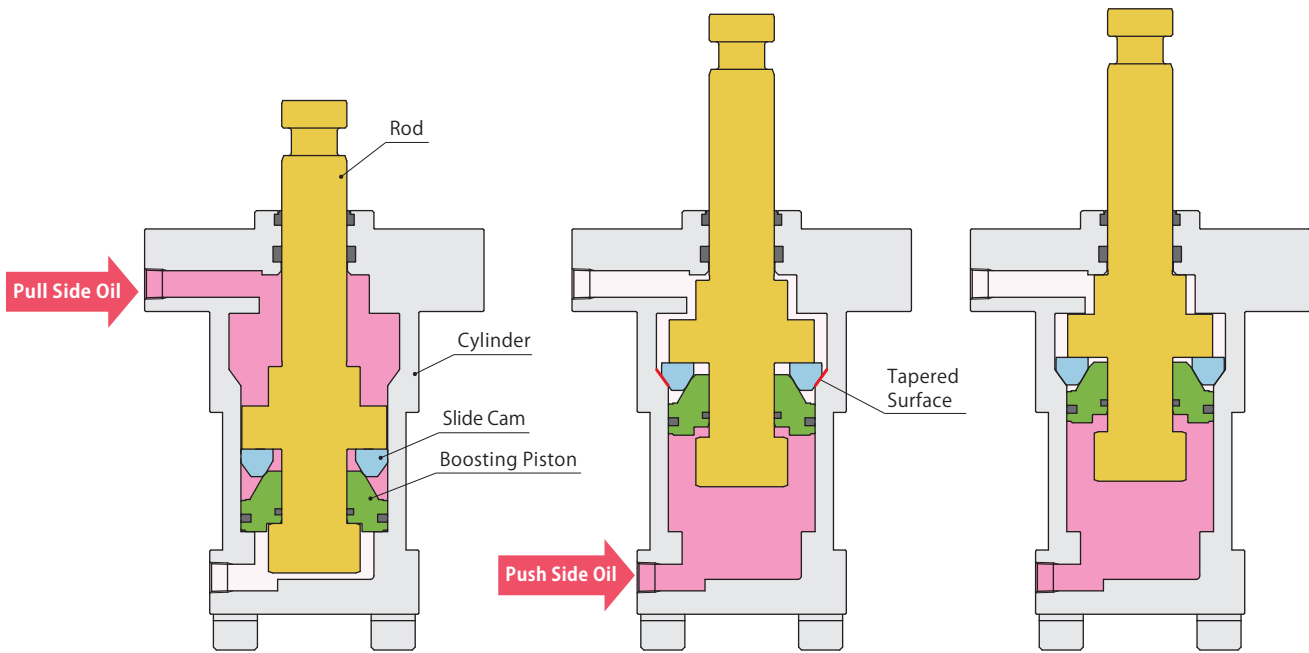

The rod is mechanically locked when the slide cam touches the tapered surface of the cylinder. Mechanical lock withstands the casting pressure and prevents the core from returning.

Pulling Action

Pushing Action

Powerful Holding Force !

High-Power Core Push Cylinder can be **extremely compact** compared to a general linear cylinder with the same force.

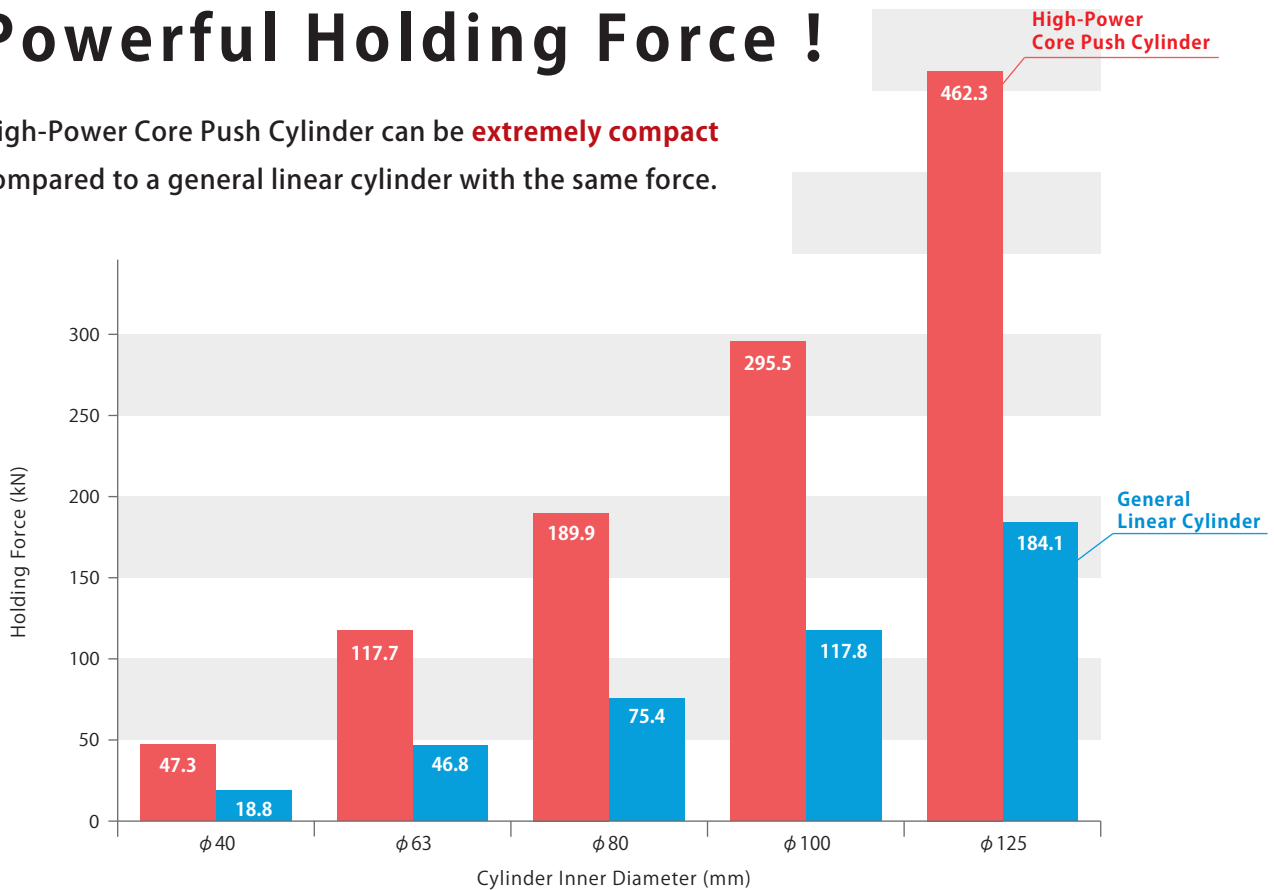

Holding Force Comparison (At Hydraulic Pressure : 15 MPa)

Model No. Indication

PCE 100 1 - B C F - 100 - V - 0 - XH - S3

1
2
3
4
5
6
7
8
9
10

1 Cylinder Inner Diameter

- 040** : φ 40 mm
- 063** : φ 63 mm
- 080** : φ 80 mm
- 100** : φ 100 mm
- 125** : φ 125 mm

2 Design No.

- 1** : Revision Number

3 Mounting Spigot Joint Diameter

- A** : Type A
- B** : Type B

※. Refer to the external dimensions on P.13 for further information.

Mounting Spigot Joint Diam.

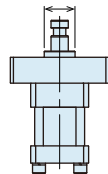

4 Rod Shape

- C** : Coupling
- T** : Male Thread

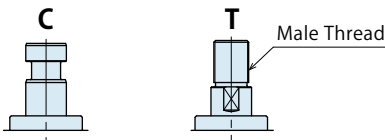

5 Hydraulic Port Position

- F** : Front
- R** : Right Side
- L** : Left Side

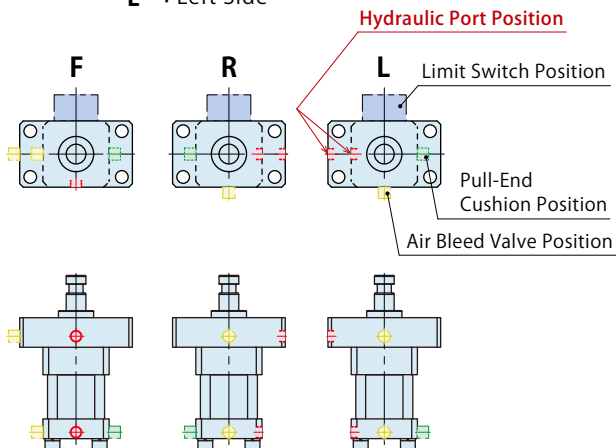

6 Stroke

- 30 ~ 150** : Select from Stroke 30 ~ 150mm

※. In case of **1** Cylinder Inner Diameter **040** : **6** Stroke is **30~100**.
 ※. Please specify **6** Stroke in 1mm increments.

7 Operating Temperature

- N** : Standard 0 ~ 70 °C
- V** : High Temperature 0 ~ 120 °C

8 Usable Fluid

- 0** : General Hydraulic Oil (Equivalent to ISO-VG-32)
- G** : Water·Glycol
- S** : Silicon Oil
- F** : Fatty Acid Ester

※. Refer to "Appropriate Fluid According to Packing Material" on the next page for further information.

9 Option

- Blank** : None
- X** : with Air Bleed Valve
- H** : with Pull-End Cushion
- XH** : with Air Bleed Valve and Pull-End Cushion

X : with Air Bleed Valve
Able to release the air in the circuit with a wrench.

H : with Pull-End Cushion
Able to cushion at the pull end by adjusting flow rate with a wrench.

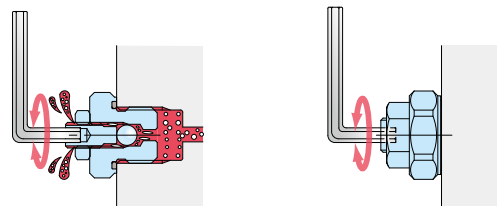

※. In case of **1** Cylinder Inner Diameter **040** : **9** Option is **Blank, X** only.

10 Limit Switch

- Blank** : No Limit Switch
- S3** : With Limit Switch

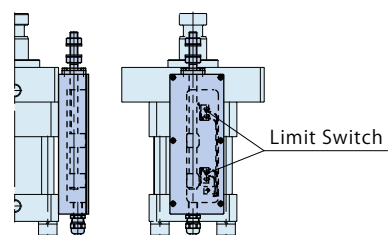

※. Refer to P.45 "Limit Switch" for further information.

Specifications

Model No.		PCE0401	PCE0631	PCE0801	PCE1001	PCE1251
Cylinder Inner Diameter	mm	φ 40	φ 63	φ 80	φ 100	φ 125
Stroke (in 1mm increments)	mm	30~100				
Boosting Stroke Range	mm	3				
Cylinder ^{**1}	Push Side	1.26×Stroke+6.0	3.12×Stroke+22.3	5.03×Stroke+37.8	7.85×Stroke+62.6	12.27×Stroke+107.8
Capacity cm ³	Pull Side	1.00×Stroke+6.0	2.50×Stroke+22.3	4.04×Stroke+37.8	6.26×Stroke+62.6	9.81×Stroke+107.8
Operating Pressure	MPa	15.0				
Max. Operating Pressure	MPa	16.0				
Min. Operating Pressure ^{**2}	MPa	1.0				
Withstanding Pressure	MPa	24.0				
Operating Temperature	°C	Z: N: Standard 0 ~ 70 V: High Temperature 0 ~ 120				
Weight ^{**1}	kg	0.011×Stroke+4.9	0.020×Stroke+11.1	0.030×Stroke+17.8	0.040×Stroke+29.8	0.058×Stroke+47.7

Notes :

- ※1. The stroke in calculation of cylinder capacity and weight should be calculated in mm.
- ※2. Minimum pressure to operate the cylinder with no load.

Appropriate Fluid According to Packing Material

Operating Temperature	Packing Material	Appropriate Fluid			
		O: General Hydraulic Oil	G: Water·Glycol	S: Silicon Oil	F: Fatty Acid Ester
N: Standard 0 ~ 70 °C	Nitrile Rubber (NBR)	○	○	○	○
V: High Temperature 0 ~ 120 °C	Fluor Rubber (FKM)	○	△ ^{※3}	○	○

Notes :

- ※3. Please contact us in case of using G : Water · Glycol with V : High Temperature.
- 1. Please contact us for other conditions.

Cylinder Thrust Force

(kN)

Model No.		PCE0401	PCE0631	PCE0801	PCE1001	PCE1251	
Push Side	Holding Force	at P: 15MPa	47.3	117.7	189.9	295.5	462.3
	(Push End ^{※4} ~ 5mm)	Calculation Formula ^{※5}	H=3.15×P	H=7.85×P	H=12.66×P	H=19.70×P	H=30.82×P
		at P: 15MPa	29.6	73.5	118.5	184.8	288.9
	(5mm ^{※4} ~ Pull End)	Calculation Formula ^{※5}	F ₁ =1.97×P	F ₁ =4.90×P	F ₁ =7.90×P	F ₁ =12.32×P	F ₁ =19.26×P
		at P: 15MPa	18.8	46.8	75.4	117.8	184.1
	Pulling Force	at P: 15MPa	15	37.5	60.6	94	147.1
Calculation Formula ^{※5}		F ₃ =1.00×P	F ₃ =2.50×P	F ₃ =4.04×P	F ₃ =6.27×P	F ₃ =9.81×P	

Notes :

- ※4. In case of PCE0401 : 3mm
- ※5. H : Holding Force (kN), F₁ : Boosting Force (kN), F₂ : Idle Force (kN), F₃ : Pulling Force (kN), P : Supply Hydraulic Pressure (MPa).

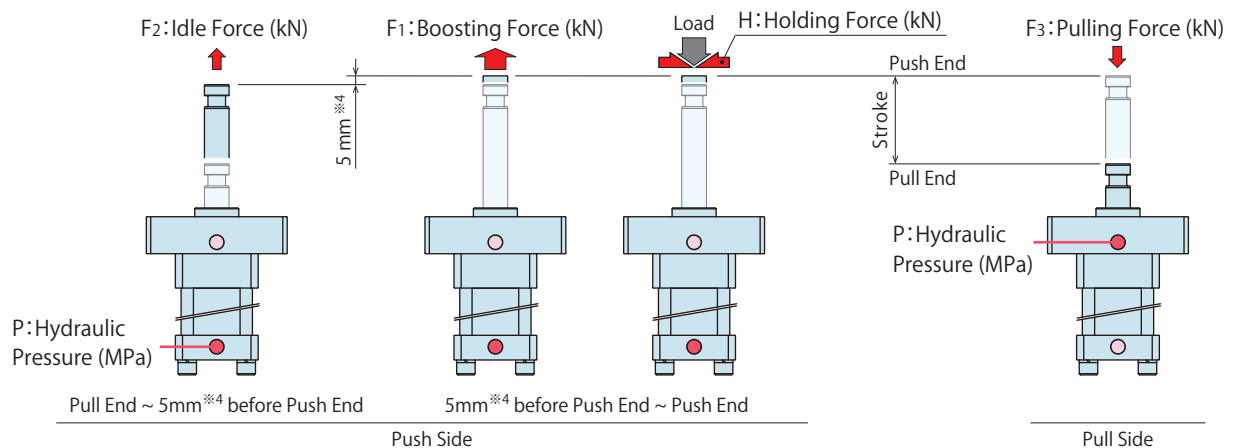

External Dimensions

※ This drawing shows the pull end state.

Rod Shape **C : Coupling**, Port Position **F : Front**, Option **Blank : None X : with Air Bleed Valve**

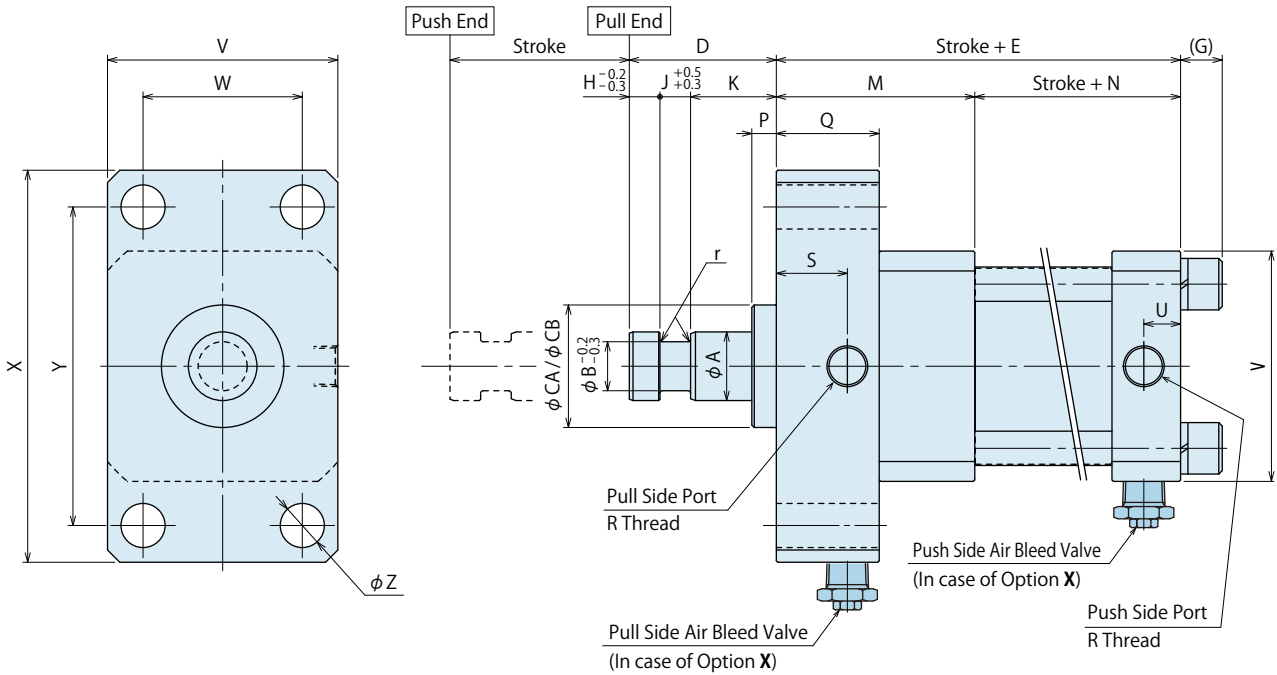

Rod Shape **C : Coupling**, Port Position **F : Front**,

Option **H : with Pull-End Cushion**, **XH : with Air Bleed Valve and Pull-End Cushion**

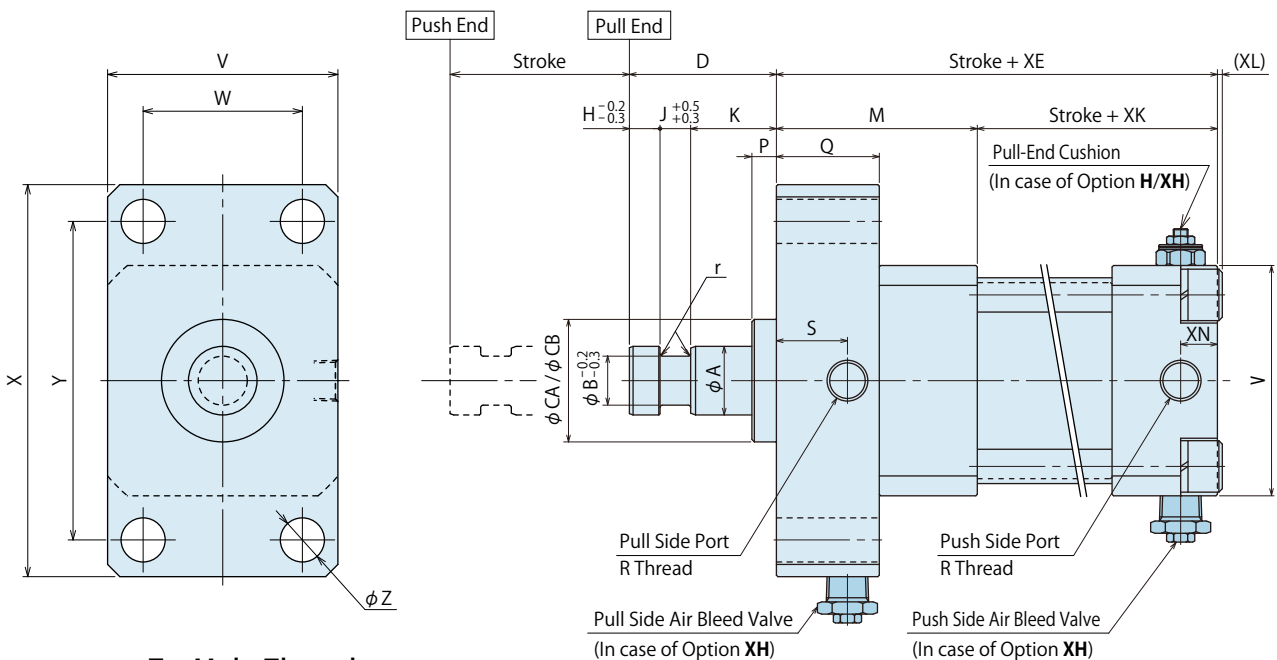

Rod Shape **T : Male Thread**

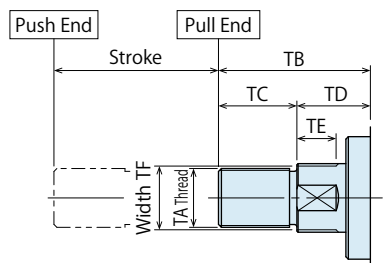

- High-Power Core Push Cylinder
- High-Speed Core Pull Cylinder
- High-Speed Core Pull Cylinder Compact Model
- High-Power Core Pull Cylinder
- Flat Cylinder

Port Position F : Front

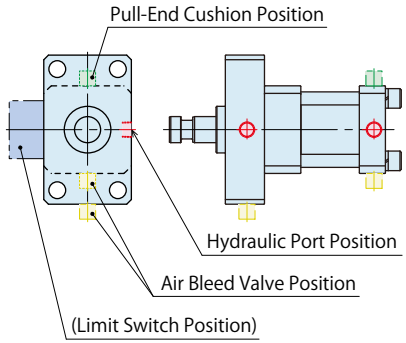

Port Position R : Right Side

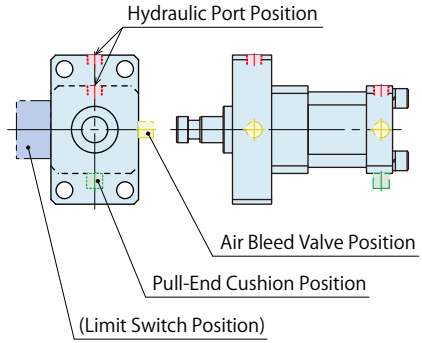

Port Position L : Left Side

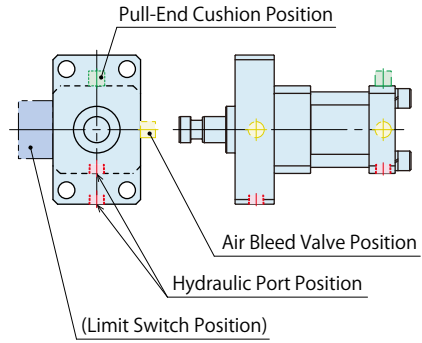

External Dimension List

- Rod Shape **C : Coupling**, Option **Blank : None**, **X : with Air Bleed Valve** (mm)

Model No.	PCE0401-C PCE0401-C-X	PCE0631-C PCE0631-C-X	PCE0801-C PCE0801-C-X	PCE1001-C PCE1001-C-X	PCE1251-C PCE1251-C-X
A	18 $f7^{-0.016}_{-0.034}$	28 $f7^{-0.020}_{-0.041}$	35.5 $f7^{-0.025}_{-0.050}$	45 $f7^{-0.025}_{-0.050}$	56 $f7^{-0.030}_{-0.060}$
B	13	20	25	31	38
CA (Mounting Spigot Joint Diam. A)	30 $f7^{-0.020}_{-0.041}$	43 $f7^{-0.025}_{-0.050}$	52 $f7^{-0.030}_{-0.060}$	62 $f7^{-0.030}_{-0.060}$	72 $f7^{-0.030}_{-0.060}$
CB (Mounting Spigot Joint Diam. B)	36 $f7^{-0.025}_{-0.050}$	50 $f7^{-0.025}_{-0.050}$	65 $f7^{-0.030}_{-0.060}$	70 $f7^{-0.030}_{-0.060}$	85 $f7^{-0.036}_{-0.071}$
D	55	60	70	75	90
E	125	142	160	185	210
G	12.5	17	19.5	24.5	29
H	12.5	12.5	15	15	20
J	12.5	12.5	15	15	20
K	30	35	40	45	50
M	77	89	100	120	135
N	48	53	60	65	75
P	5	10	10	10	10
Q	42	42	45	55	60
R	Rc3/8	Rc3/8	Rc3/8	Rc1/2	Rc1/2
S	29	29	30	35	40
U	15	15	20	21	25
V	65	94	114	136	165
W	40	65	80	100	125
X	118	160	185	220	255
Y	94	130	150	180	210
Z	14	18	18	22	26
r	R1	R1	R1.5	R2	R2
Mounting Bolt	M12×1.75	M16×2	M16×2	M20×2.5	M24×3

- Option **H : with Pull-End Cushion**, **XH : with Air Bleed Valve and Pull-End Cushion**

Unlisted dimensions are the same with Option **Blank : None** and **X : with Air Bleed Valve**. (mm)

Model No.	PCE0631-H PCE0631-XH	PCE0801-H PCE0801-XH	PCE1001-H PCE1001-XH	PCE1251-H PCE1251-XH
XE	150	165	190	215
XK	68	75	80	90
XL	2	4.5	9.5	14
XN	15	19	22	21

- Rod Shape **T : Male Thread** (mm)

Model No.	PCE0401-T	PCE0631-T	PCE0801-T	PCE1001-T	PCE1251-T
TA	M16×1.5	M24×1.5	M30×1.5	M40×1.5	M50×1.5
TB	45	62	66	80	96
TC	20	32	36	45	56
TD	25	30	30	35	40
TE	12	16	17	22	23
TF	17	26	32	41	54

For Diecast Systems

High-Speed Core Pull Cylinder

Model PCB

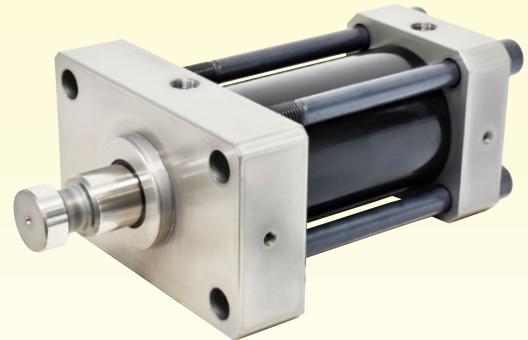

Maintains Pulling Force with Much Less Cylinder Capacity

Interchangeable with General Core Cylinder / Reduce Cycle Time

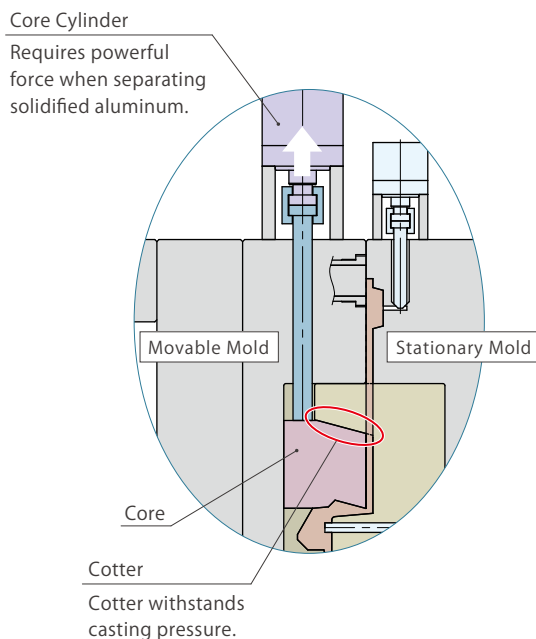

Core-Pulling Mechanism for Diecasting Molds

Cylinder for sliding core requires strong force when pulling out the core after casting. No great power is required when moving forward and backward.

Kosmek High-Speed Core Pull Cylinder exerts high power only when pulling out the core.

Idle force is **20% of pulling force**

so that **working oil amount will be reduced.**

High-Power
Core Push Cylinder

High-Speed
Core Pull Cylinder

High-Speed
Core Pull Cylinder
Compact Model

High-Power
Core Pull Cylinder

Flat Cylinder

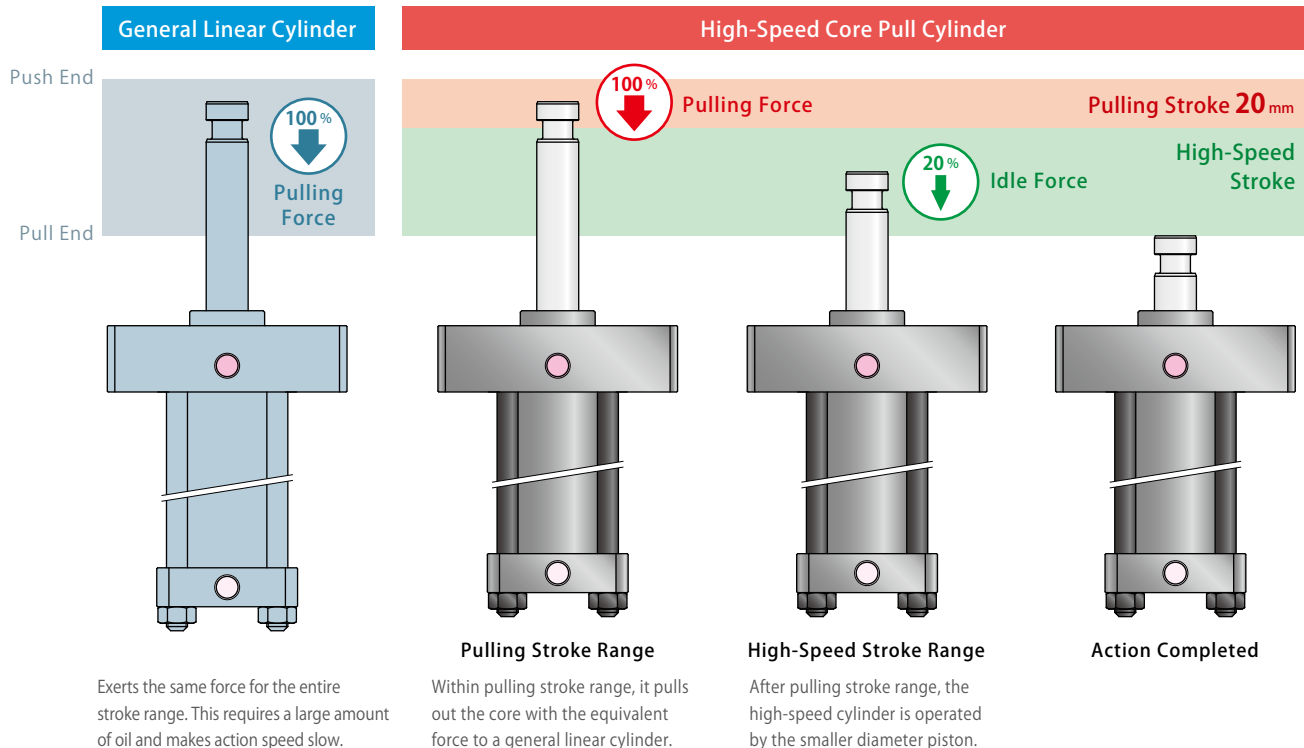

Pulling Action

Compared to a general Linear Cylinder,
Reduces about 60% of oil amount.

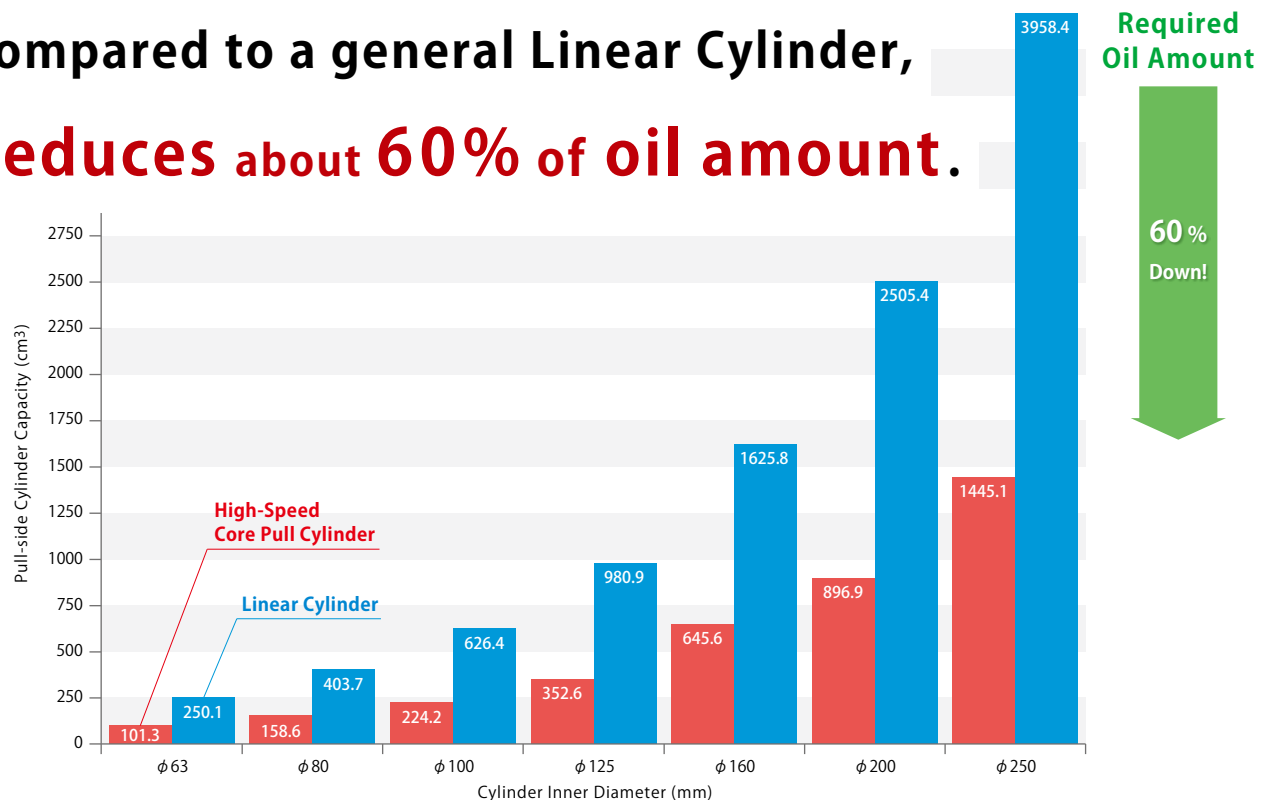

Pull-side Cylinder Capacity Comparison (Stroke : 100 mm)

Smaller cylinder capacity enables

high speed and reduces cycle time.

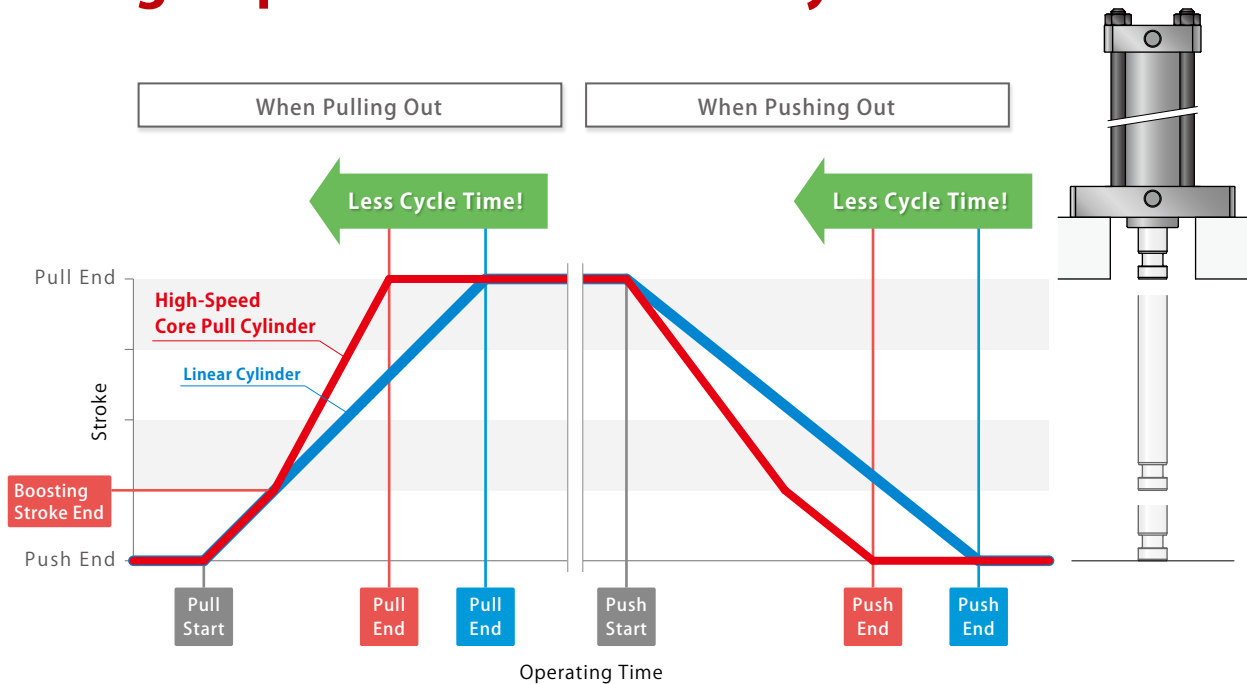

Operating Time Image (Compared to cylinder with the same pulling force.)

Only several sec reduction per shot, yet it will

make a huge difference in the long term.

Case Study with 350ton Diecasting Machine

[Condition] Reduced Cycle Time per Shot: 4.3 sec. (before Kaizen: 36.7 sec, after Kaizen: 32.4 sec.)

Operating for **1 Hour**

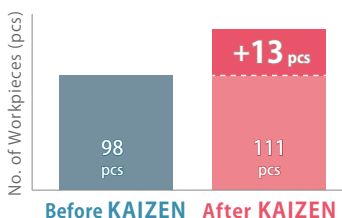

13 more workpieces
by one-hour operation !

Operating for **1 Day**

※ 1 Day = Operating for 20 hrs.

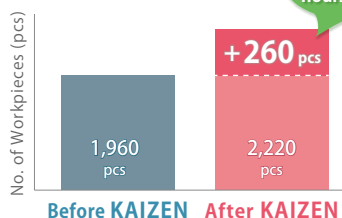

260 more workpieces
by one-day operation !

Operating for **1 Year**

※ 1 Year = Operating for 300 days.

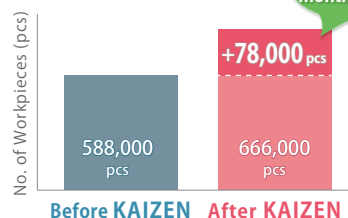

78,000 more workpieces
by one-year operation !

4.3 sec per shot allows for **78,000 more workpieces production** possible in one year.

Also, **12-month amount** (before Kaizen) can be manufactured in **10.6 months**.

※ Improvement Result per Diecasting Machine

General Linear Cylinder is **Interchangeable** with High-Speed Core Pull Cylinder

Size Comparison Example

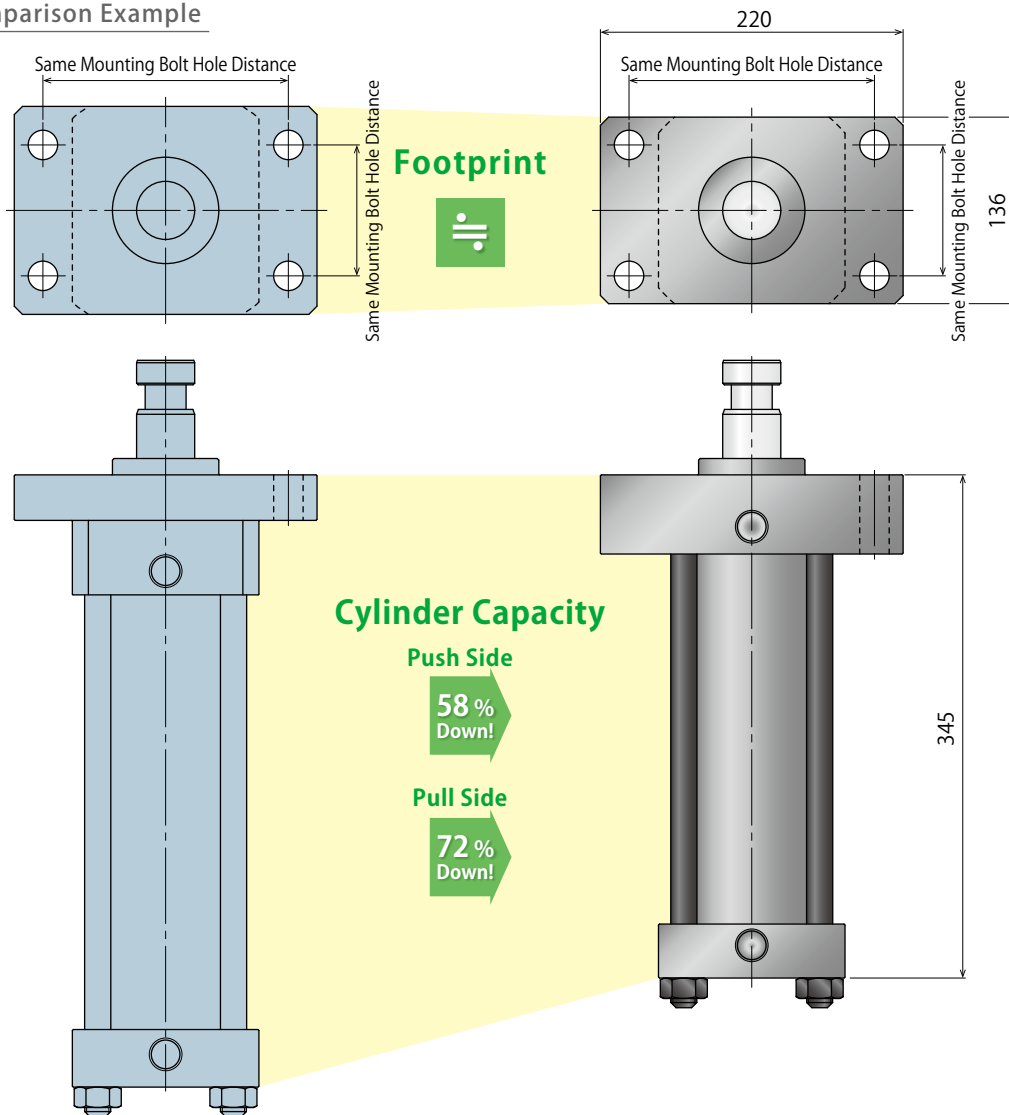

General Linear Cylinder

Cylinder Inner Diameter ϕ 100 mm

Pulling Force 94 kN

Weight About 39 kg

Cylinder Weight

9 %
Down!

High-Speed Core Pull Cylinder

Cylinder Inner Diameter ϕ 100 mm

Pulling Force 94 kN

Weight About 35.3 kg

※ Stroke: 200 mm

Hydraulic Pressure: 15 MPa

Drastically improves the productivity
by interchanging to High-Speed Core Pull Cylinder.

Model No. Indication

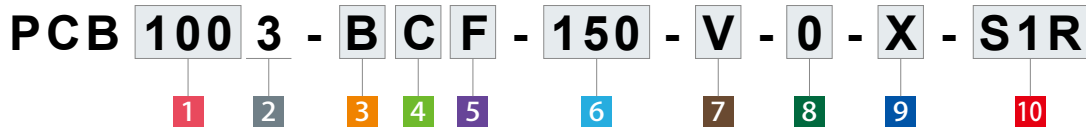

1 Cylinder Inner Diameter

063 : ϕ 63 mm	160 : ϕ 160 mm
080 : ϕ 80 mm	200 : ϕ 200 mm
100 : ϕ 100 mm	250 : ϕ 250 mm
125 : ϕ 125 mm	

2 Design No.

3 : Revision Number

3 Mounting Spigot Joint Diameter

- A** : Type A
- B** : Type B

Mounting Spigot Joint Diam.

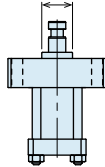

※. Refer to the external dimensions on P.21 for further information.

※. Only **3A**: Type A for **1** 160, 200, 250.

4 Rod Shape

- C** : Coupling
- T** : Male Thread

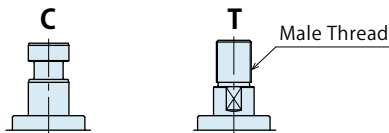

※. Only **4C**: Coupling for **1** 160, 200, 250.

5 Hydraulic Port Position

- F** : Front
- R** : Right Side
- L** : Left Side

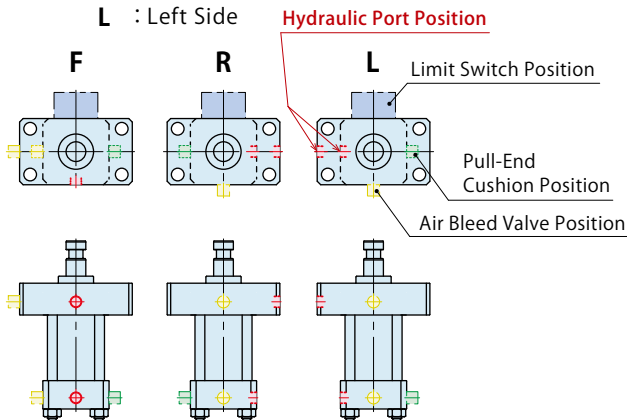

6 Stroke

40 ~ 500 : Select from Stroke 40 ~ 500mm

※. **6 Stroke** differs depending on **1 Cylinder Inner Diameter**. Refer to the stroke on the specifications on the next page.

※. Specify **6 Stroke** in 5mm increments.

7 Operating Temperature

- N** : Standard 0 ~ 70 °C
- V** : High Temperature 0 ~ 120 °C

8 Usable Fluid

- 0** : General Hydraulic Oil (Equivalent to ISO-VG-32)
- G** : Water·Glycol
- S** : Silicon Oil
- F** : Fatty Acid Ester

※. Refer to "Appropriate Fluid According to Packing Material" on the next page for further information.

9 Option

Blank : None

X : with Air Bleed Valve

H : with Pull-End Cushion

XH : with Air Bleed Valve and Pull-End Cushion

X : with Air Bleed Valve
Able to release the air in the circuit with a wrench.

H : with Pull-End Cushion
Able to cushion at the pull end by adjusting flow rate with a wrench.

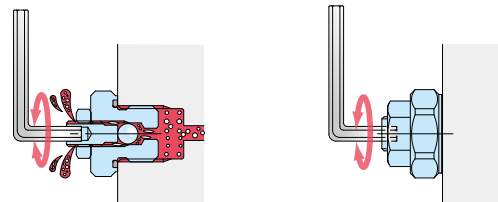

10 Limit Switch

Blank : No Limit Switch

S1R : Standard Model } Mounting position is as shown in the below drawing.

S1L : Standard Model }

S2R : Relay Box Model } Mounting position is as shown in the below drawing.

S2L : Relay Box Model }

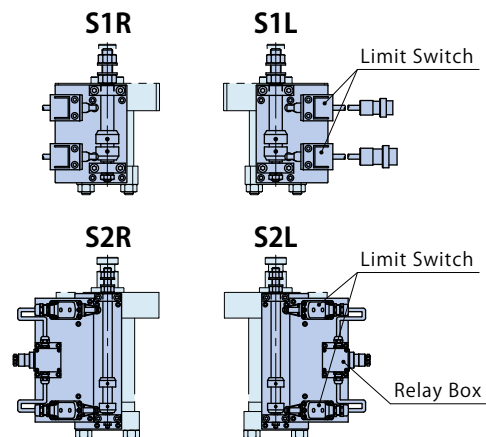

※. Refer to "Limit Switch" on P.45 for further information.

Specifications

Model No.		PCB0633	PCB0803	PCB1003	PCB1253	PCB1603	PCB2003	PCB2503
Cylinder Inner Diameter	mm	φ 63	φ 80	φ 100	φ 125	φ 160	φ 200	φ 250
Stroke (in 5mm increments)	mm	40 ~ 250	40 ~ 300	40 ~ 400	40 ~ 500			
Cylinder ^{※1}	Push Side	1.26×Stroke+37.2	1.96×Stroke+61.3	2.83×Stroke+100.5	4.42×Stroke+157.1	7.85×Stroke+245.0	11.31×Stroke+402.1	17.67×Stroke+628.3
Capacity	Pull Side	0.64×Stroke+37.2	0.97×Stroke+61.3	1.24×Stroke+100.5	1.95×Stroke+157.1	4.01×Stroke+245.0	4.95×Stroke+402.1	8.17×Stroke+628.3
Operating Pressure	MPa	15.0						
Max. Operating Pressure	MPa	16.0						
Min. Operating Pressure ^{※2}	MPa	1.0						
Withstanding Pressure	MPa	24.0						
Operating Temperature	°C	7 N: Standard 0 ~ 70 V: High Temperature 0 ~ 120						
Weight ^{※1}	kg	0.033×Stroke+7.0	0.053×Stroke+11.0	0.083×Stroke+18.7	0.130×Stroke+29.4	0.180×Stroke+75.5	0.293×Stroke+139.5	0.440×Stroke+224.5

Notes :

- ※1. The stroke in calculation of cylinder capacity and weight should be calculated in mm.
- ※2. Minimum pressure to operate the cylinder with no load.

Appropriate Fluid According to Packing Material

7 Operating Temperature	Packing Material	Appropriate Fluid			
		0: General Hydraulic Oil	G: Water·Glycol	S: Silicon Oil	F: Fatty Acid Ester
N: Standard 0 ~ 70 °C	Nitrile Rubber (NBR)	○	○	○	○
V: High Temperature 0 ~ 120 °C	Fluor Rubber (FKM)	○	△ ^{※3}	○	○

Notes :

- ※3. Please contact us when using 8 G : Water · Glycol with 7 V : High Temperature.
- 1. Please contact us for other conditions.

Cylinder Thrust Force

(kN)

Model No.		PCB0633	PCB0803	PCB1003	PCB1253	PCB1603	PCB2003	PCB2503	
Pushing Force	at P: 15MPa	18.8	29.5	42.4	66.3	117.8	169.6	265.1	
	Calculation Formula ^{※4}	F ₁ =1.26×P	F ₁ =1.96×P	F ₁ =2.83×P	F ₁ =4.42×P	F ₁ =7.85×P	F ₁ =11.31×P	F ₁ =17.67×P	
Pull Side	Pulling Force	37.5	60.6	94.0	147.1	243.9	375.8	593.8	
	(Push End ~ 20mm)	Calculation Formula ^{※4}	F ₂ =2.50×P	F ₂ =4.04×P	F ₂ =6.26×P	F ₂ =9.81×P	F ₂ =16.26×P	F ₂ =25.05×P	F ₂ =39.58×P
	Idle Force	9.6	14.6	18.6	29.3	60.1	74.2	122.5	
	(20mm ~ Pull End)	Calculation Formula ^{※4}	F ₃ =0.64×P	F ₃ =0.97×P	F ₃ =1.24×P	F ₃ =1.95×P	F ₃ =4.01×P	F ₃ =4.95×P	F ₃ =8.17×P

Note :

- ※4. F₁ : Pushing Force (kN), F₂ : Pulling Force (kN), F₃ : Idle Force (kN), P : Hydraulic Pressure (MPa)

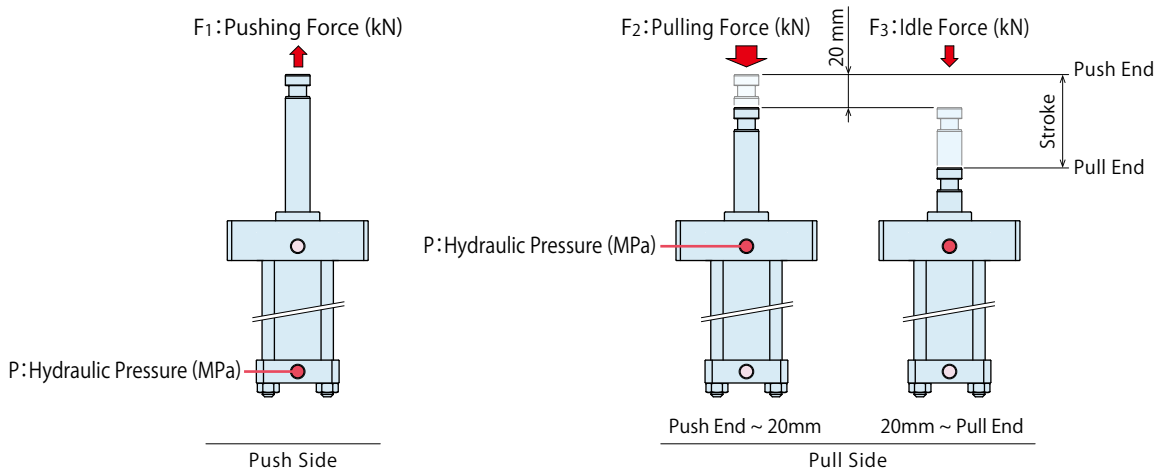

External Dimensions : Cylinder Inner Diameter **063 ~ 200**

※ This drawing shows the pull end state of PCB0633 ~ PCB2003.

Rod Shape **C : Coupling**, Port Position **F : Front**, Option **Blank : None**

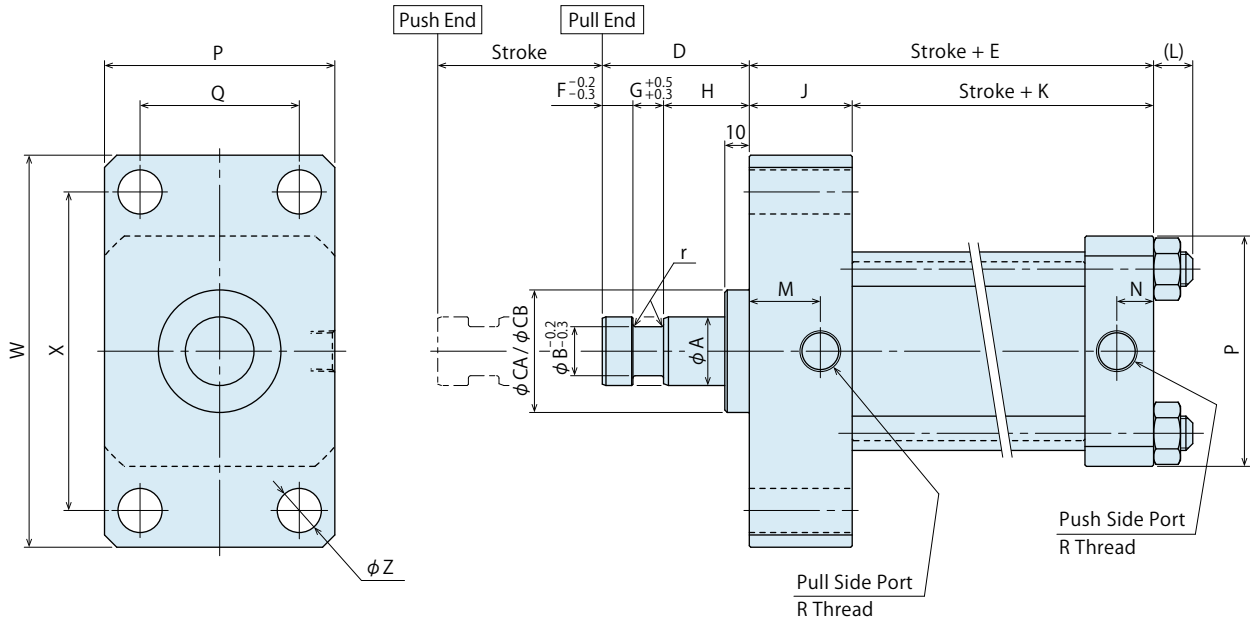

Rod Shape **C : Coupling**, Port Position **F : Front**,

Option **X : with Air Bleed Valve**,

Option **H : with Pull-End Cushion**, Option **XH : with Air Bleed Valve and Pull-End Cushion**

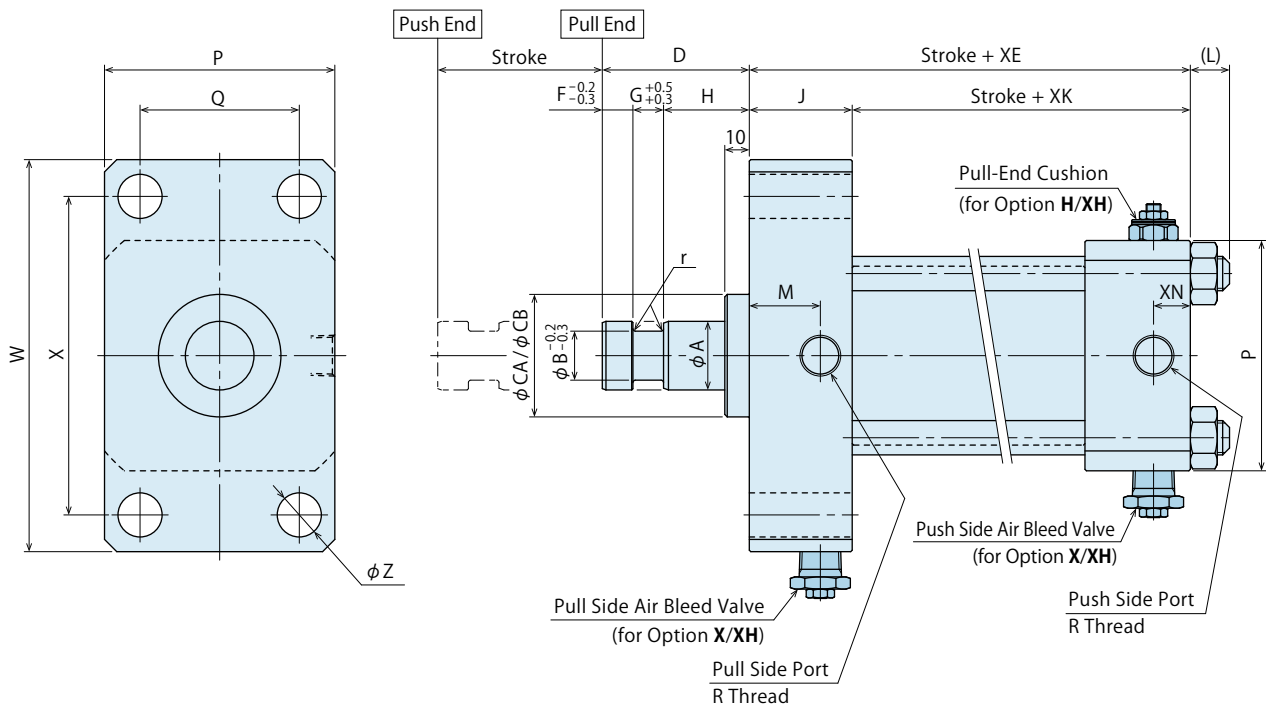

Rod Shape **T : Male Thread**

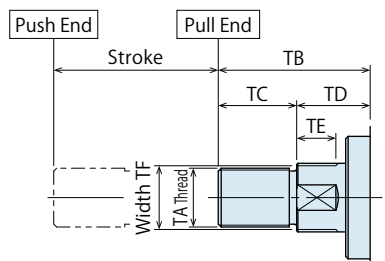

- High-Power Core Push Cylinder
- High-Speed Core Pull Cylinder
- High-Speed Core Pull Cylinder Compact Model
- High-Power Core Pull Cylinder
- Flat Cylinder

Port Position F : Front

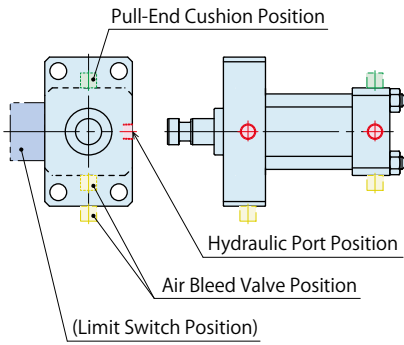

Port Position R : Right Side

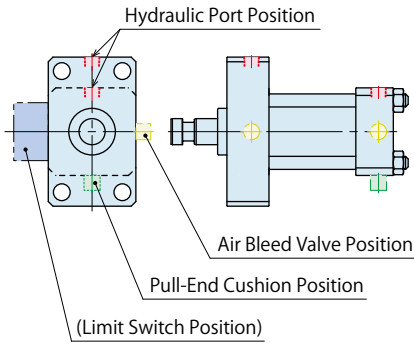

Port Position L : Left Side

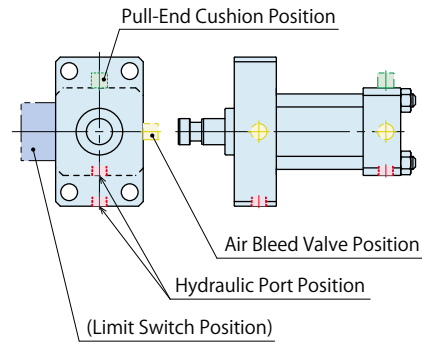

External Dimension List

Rod Shape C : Coupling, Option Blank : None

(mm)

Model No.	PCB0633-C	PCB0803-C	PCB1003-C	PCB1253-C	PCB1603-C	PCB2003-C
A	28 $f7_{-0.020}^{-0.041}$	35.5 $f7_{-0.025}^{-0.050}$	45 $f7_{-0.025}^{-0.050}$	56 $f7_{-0.030}^{-0.060}$	70 $f7_{-0.030}^{-0.060}$	90 $f7_{-0.036}^{-0.071}$
B	20	25	31	38	49	60
CA (Mounting Spigot Joint Diam. A)	43 $f7_{-0.025}^{-0.050}$	52 $f7_{-0.030}^{-0.060}$	62 $f7_{-0.030}^{-0.060}$	72 $f8_{-0.030}^{-0.076}$	105 $f8_{-0.036}^{-0.090}$	125 $f8_{-0.043}^{-0.106}$
CB (Mounting Spigot Joint Diam. B)	50 $f7_{-0.025}^{-0.050}$	65 $f7_{-0.030}^{-0.060}$	70 $f7_{-0.030}^{-0.060}$	85 $f8_{-0.036}^{-0.090}$	-	-
D	60	70	75	90	115	130
E	115	125	145	155	200	225
F	12.5	15	15	20	25	30
G	12.5	15	15	20	25	30
H	35	40	45	50	65	70
J	42	45	55	60	75	85
K	73	80	90	95	125	140
L	16	18	22	25	30	37
M	29	30	35	40	50	60
N	12.5	16	19	24	31	41
P	94	114	136	165	212	278
Q	65	80	100	125	160	210
R	Rc3/8	Rc3/8	Rc1/2	Rc1/2	Rc3/4	Rc3/4
W	160	185	220	255	335	405
X	130	150	180	210	275	335
Z	18	18	22	26	33	39
r	R1	R1.5	R2	R2	R3.5	R5
Mounting Bolt	M16×2	M16×2	M20×2.5	M24×3	M30×3.5	M36×4

Option X : with Air Bleed Valve, H : with Pull-End Cushion, XH : with Air Bleed Valve and Pull-End Cushion

Unlisted dimensions are the same with Option Blank : None.

(mm)

Model No.	PCB0633-□-X/H/XH	PCB0803-□-X/H/XH	PCB1003-□-X/H/XH	PCB1253-□-X/H/XH	PCB1603-□-X/H/XH	PCB2003-□-X/H/XH
XE	130	140	160	170	215	240
XK	88	95	105	110	140	155
XN	15	19	22	21	31	41

Rod Shape T : Male Thread

(mm)

Model No.	PCB0633-T	PCB0803-T	PCB1003-T	PCB1253-T
TA	M24×1.5	M30×1.5	M40×1.5	M50×1.5
TB	62	66	80	96
TC	32	36	45	56
TD	30	30	35	40
TE	16	17	22	23
TF	26	32	41	54

Port Position **F** : Front

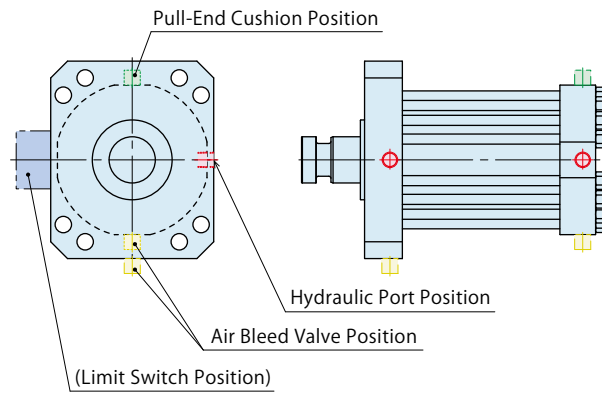

Port Position **R** : Right Side

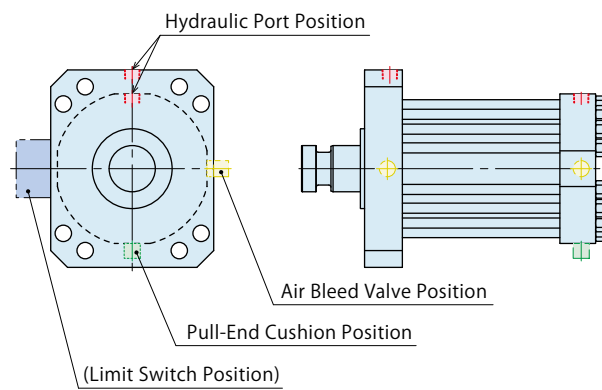

Port Position **L** : Left Side

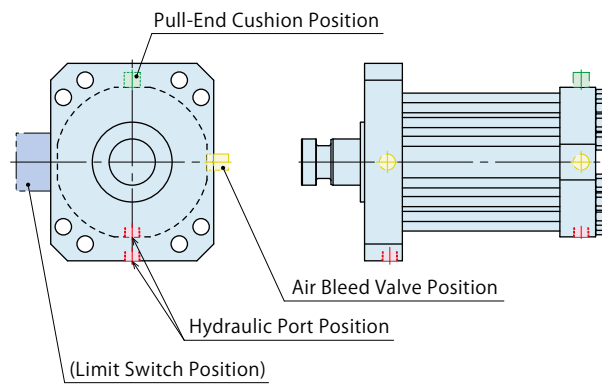

High-Power
Core Push Cylinder

High-Speed
Core Pull Cylinder

High-Speed
Core Pull Cylinder
Compact Model

High-Power
Core Pull Cylinder

Flat Cylinder

For Diecast Systems

High-Speed Core Pull Cylinder

Compact Model (Cylinder Inner Diameter $\phi 40, \phi 50\text{mm}$)

Model PCM

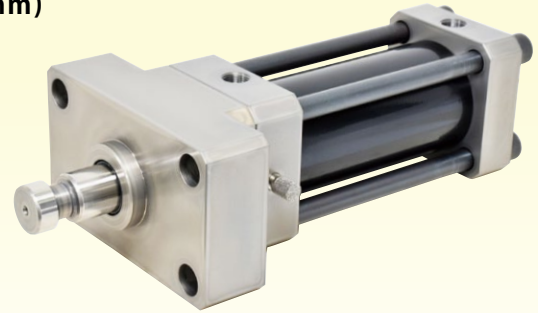

Maintains Pulling Force with Much Less Cylinder Capacity

Interchangeable with General Core Cylinder / Reduce Cycle Time

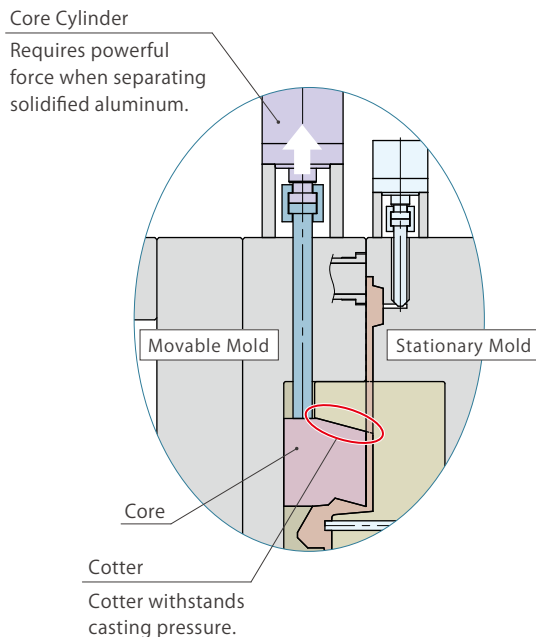

Core-Pulling Mechanism for Diecasting Molds

Cylinder for sliding core requires strong force when pulling out the core after casting. No great power is required when moving forward and backward.

Kosmek High-Speed Core Pull Cylinder exerts high power only when pulling out the core.

Idle force is **35% of pulling force**

so that **working oil amount will be reduced.**

High-Power
Core Push CylinderHigh-Speed
Core Pull CylinderHigh-Speed
Core Pull Cylinder
Compact ModelHigh-Power
Core Pull Cylinder

Flat Cylinder

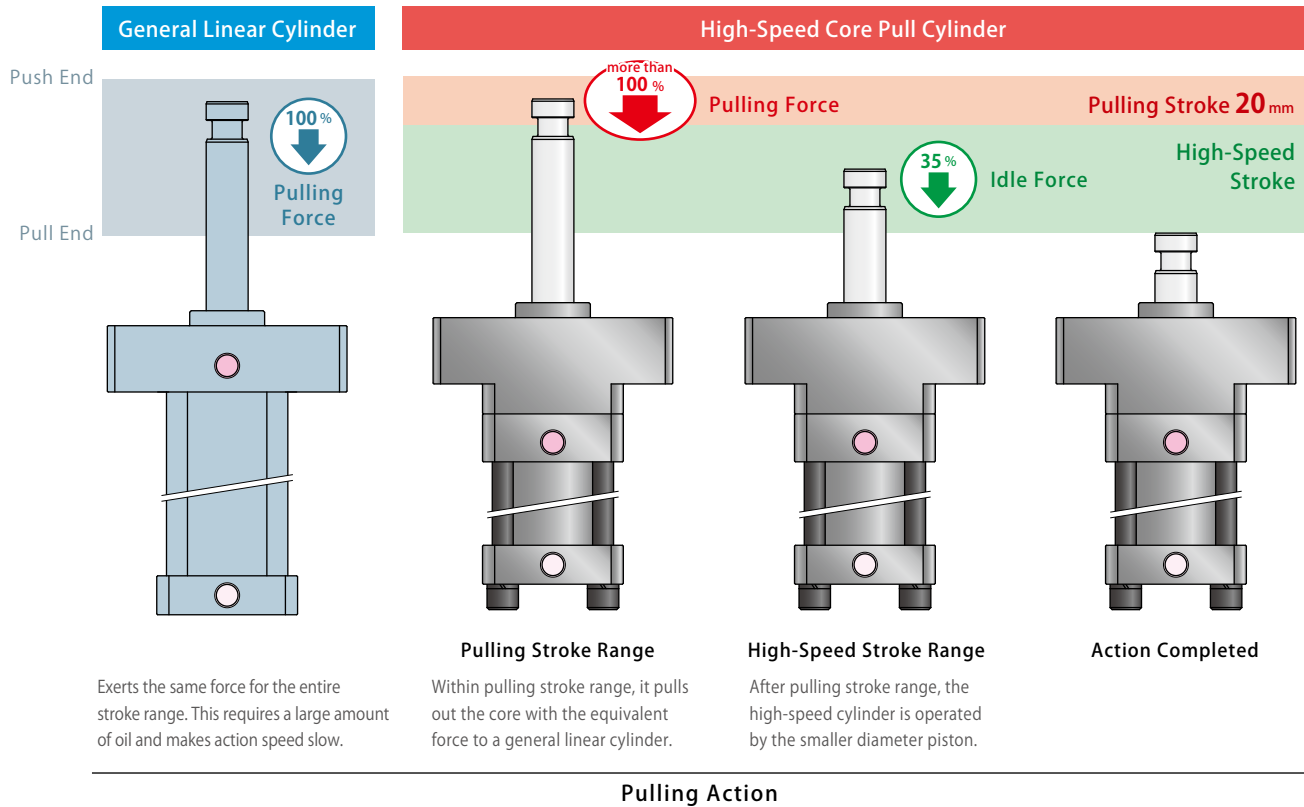

Compared to a general Linear Cylinder,

Reduces about 45% of oil amount.

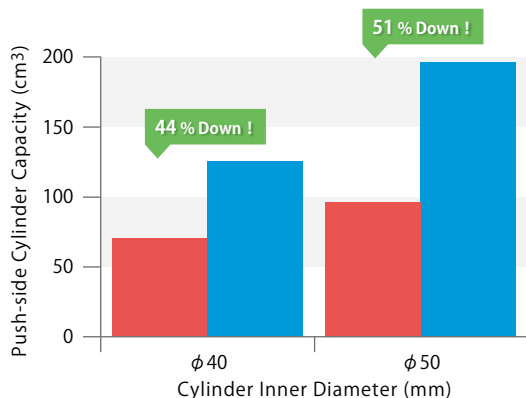

Push-side Cylinder Capacity Comparison
(Stroke : 100 mm)

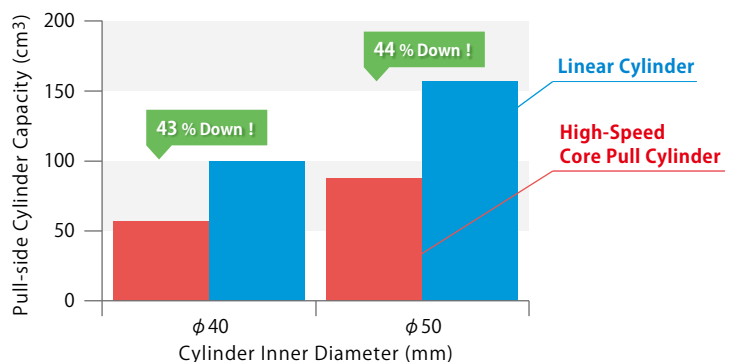

Pull-side Cylinder Capacity Comparison
(Stroke : 100 mm)

Smaller cylinder capacity enables

high speed and reduces cycle time.

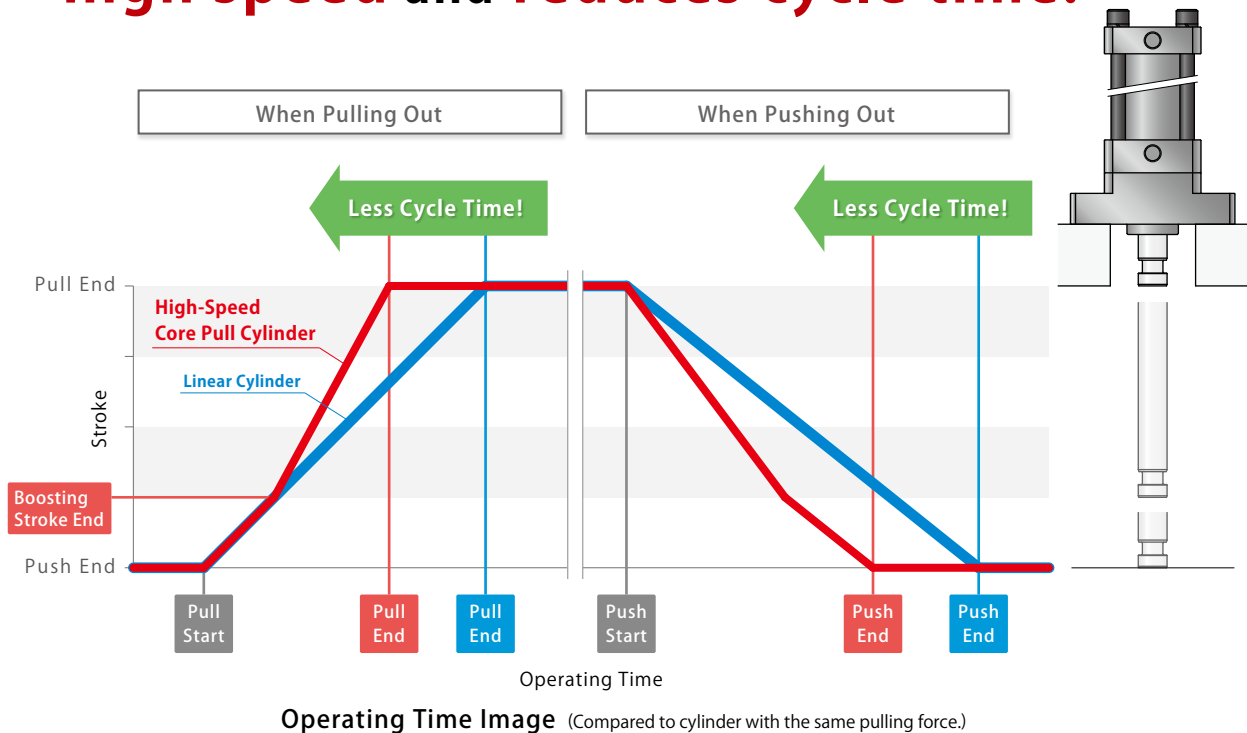

Only several sec reduction per shot, yet it will

make a huge difference in the long term.

Case Study with 850ton Diecasting Machine

【Condition】 Reduced Cycle Time per Shot: 3 sec. (before Kaizen: 27 sec, after Kaizen: 24 sec.)

Operating for **1 Hour**

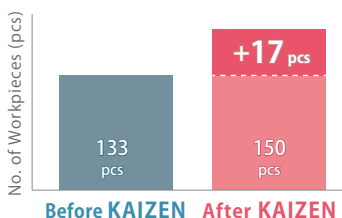

17 more workpieces
by one-hour operation !

Operating for **1 Day**

※ 1 Day = Operating for 20 hrs.

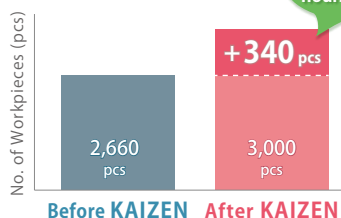

340 more workpieces
by one-day operation !

2.3 hours' worth!

Operating for **1 Year**

※ 1 Year = Operating for 300 days.



102,000 more workpieces
by one-year operation !

1.4 months' worth!

3 sec per shot allows for 102,000 more workpieces production possible in one year.

Also, 12-month amount (before Kaizen) can be manufactured in 10.6 months.

※ Improvement Result per Diecasting Machine

General Linear Cylinder is **Interchangeable** with High-Speed Core Pull Cylinder

Size Comparison ※ When stroke is 100 mm and supply hydraulic pressure is 14 MPa.

General Linear Cylinder

Cylinder Inner Diameter $\phi 40$ mm

Pulling Force **14 kN**

Cylinder Capacity

Push Side Pull Side

44 %
Down!

43 %
Down!

High-Speed Core Pull Cylinder

Cylinder Inner Diameter $\phi 40$ mm

Pulling Force **14.7 kN**

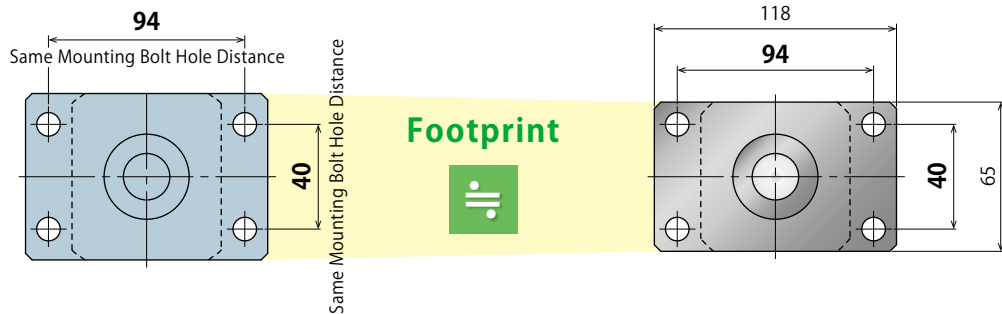

General Linear Cylinder

Cylinder Inner Diameter $\phi 50$ mm

Pulling Force **22 kN**

Cylinder Capacity

Push Side Pull Side

51 %
Down!

44 %
Down!

High-Speed Core Pull Cylinder

Cylinder Inner Diameter $\phi 50$ mm

Pulling Force **28.7 kN**

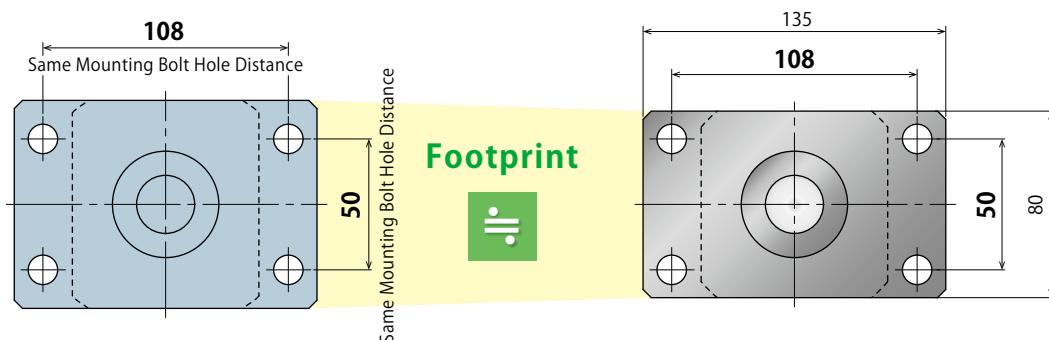

Drastically improves the productivity
by interchanging to High-Speed Core Pull Cylinder.

Model No. Indication

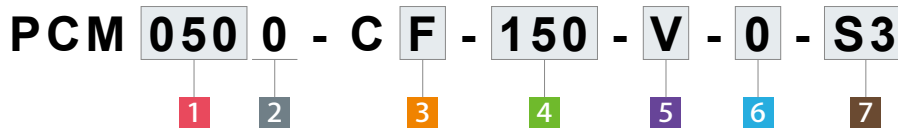

1 Cylinder Inner Diameter

- 040** : ϕ 40 mm
- 050** : ϕ 50 mm

5 Operating Temperature

- N** : Standard 0 ~ 70 °C
- V** : High Temperature 0 ~ 120 °C

2 Design No.

- 0** : Revision Number

6 Usable Fluid

- 0** : General Hydraulic Oil (Equivalent to ISO-VG-32)
- G** : Water•Glycol
- S** : Silicon Oil
- F** : Fatty Acid Ester

3 Hydraulic Port Position

- F** : Front
- R** : Right Side
- L** : Left Side

7 Limit Switch

- Blank** : No Limit Switch
- S3** : With Limit Switch

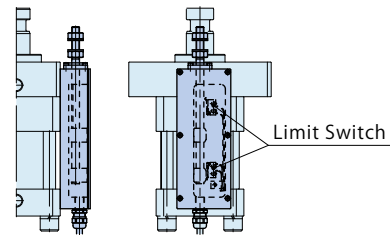
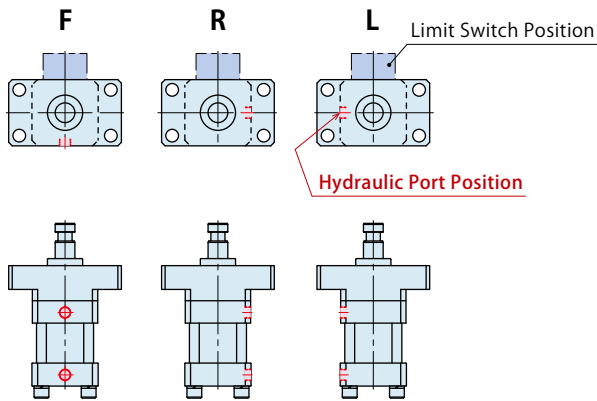

※. Refer to "Limit Switch" on P.45 for further information.

4 Stroke

40 ~ 200 : Select from Stroke 40 ~ 200mm

※. Specify **4** Stroke in 5mm increments.

Specifications

Model No.		PCM0400	PCM0500
Cylinder Inner Diameter	mm	φ 40	φ 50
Stroke (in 5mm increments)	mm	40 ~ 200	
Cylinder ^{※1}	Push Side	0.71 × Stroke	0.96 × Stroke
	Pull Side	0.45 × Stroke + 11.9	0.58 × Stroke + 29.4
Capacity	cm ³		
Max. Operating Pressure	MPa	14.0	
Min. Operating Pressure ^{※2}	MPa	3.0	
Withstanding Pressure	MPa	17.5	
Operating Temperature	°C	5 N : Standard 0 ~ 70 V : High Temperature 0 ~ 120	
Weight ^{※1}	kg	0.009 × Stroke + 5.0	0.011 × Stroke + 7.3

Notes :

- ※1. The stroke in calculation of cylinder capacity and weight should be calculated in mm.
 ※2. Minimum pressure to operate the cylinder with no load.

Appropriate Fluid According to Packing Material

5 Operating Temperature	Packing Material	Appropriate Fluid			
		0: General Hydraulic Oil	G: Water·Glycol	S: Silicon Oil	F: Fatty Acid Ester
N : Standard 0 ~ 70 °C	Nitrile Rubber (NBR)	○	○	○	○
V : High Temperature 0 ~ 120 °C	Fluor Rubber (FKM)	○	△ ^{※3}	○	○

Notes :

- ※3. Please contact us when using **6 G** : Water · Glycol with **5 V** : High Temperature.
 1. Please contact us for other conditions.

Cylinder Thrust Force

(kN)

Model No.		PCM0400	PCM0500
Pushing Force	at P: 14MPa	9.9	13.5
	Calculation Formula ^{※4}	$F_1=0.71 \times P$	$F_1=0.964 \times P$
Pull Side	Pulling Force (Push End ~ 20mm)	at P: 14MPa	14.7
		Calculation Formula ^{※4}	$F_2=1.05 \times P$
	Idle Force (20mm ~ Pull End)	at P: 14MPa	6.3
		Calculation Formula ^{※4}	$F_3=0.45 \times P$

Note :

- ※4. F_1 : Pushing Force (kN), F_2 : Pulling Force (kN), F_3 : Idle Force (kN), P : Hydraulic Pressure (MPa)

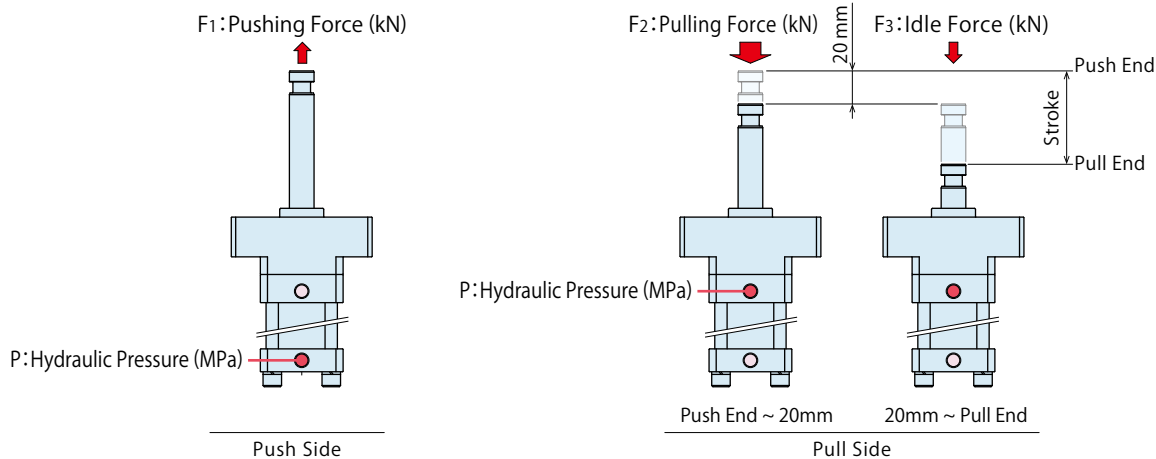

Hydraulic Port Position

Port Position F : Front

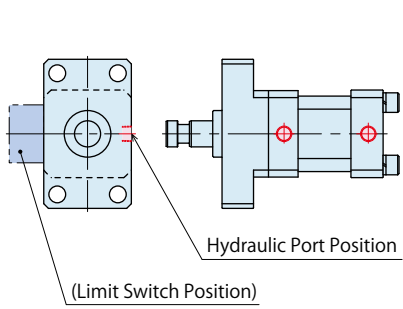

Port Position R : Right Side

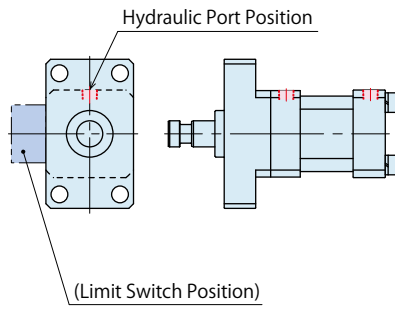

Port Position L : Left Side

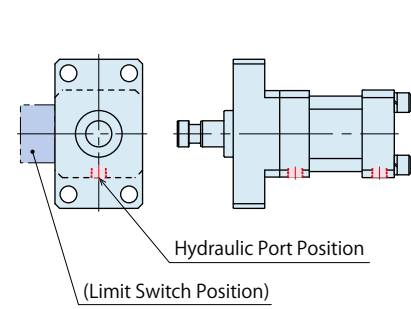

High-Power
Core Push Cylinder

High-Speed
Core Pull Cylinder

High-Speed
Core Pull Cylinder
Compact Model

High-Power
Core Pull Cylinder

Flat Cylinder

For Diecast Systems

High-Power Core Pull Cylinder

Model PCA (High-Speed Model)

Model PCC (Standard Model)

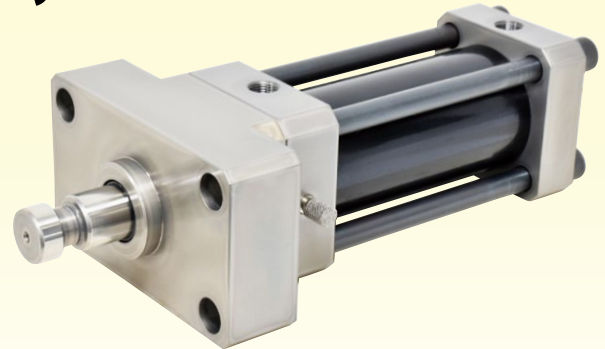

Mechanical Locking to Exert 180% Thrust Force

Compared to the Same Size Cylinder, Able to Downsize Molds and Reduce the Cycle Time.

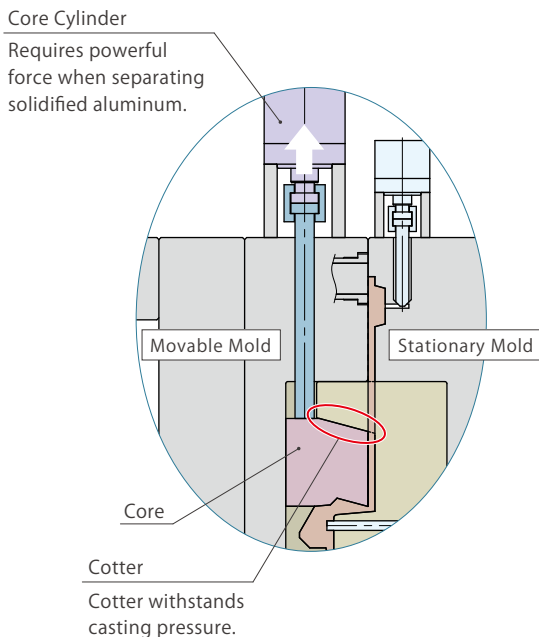

Core-Pulling Mechanism for Diecasting Molds

Cylinder for sliding core requires strong force when pulling out the core after casting. No great power is required when moving forward and backward.

Kosmek High-Power Core Pull Cylinder exerts high power only when pulling out the core.

Compared to a general linear cylinder,
Enables to Exert about 180% Thrust Force
 Idle force of high-speed model (model PCA) is
20% of cylinder force so that
working oil amount will be reduced.

- High-Power Core Push Cylinder
- High-Speed Core Pull Cylinder
- High-Speed Core Pull Cylinder Compact Model
- High-Power Core Pull Cylinder
- Flat Cylinder

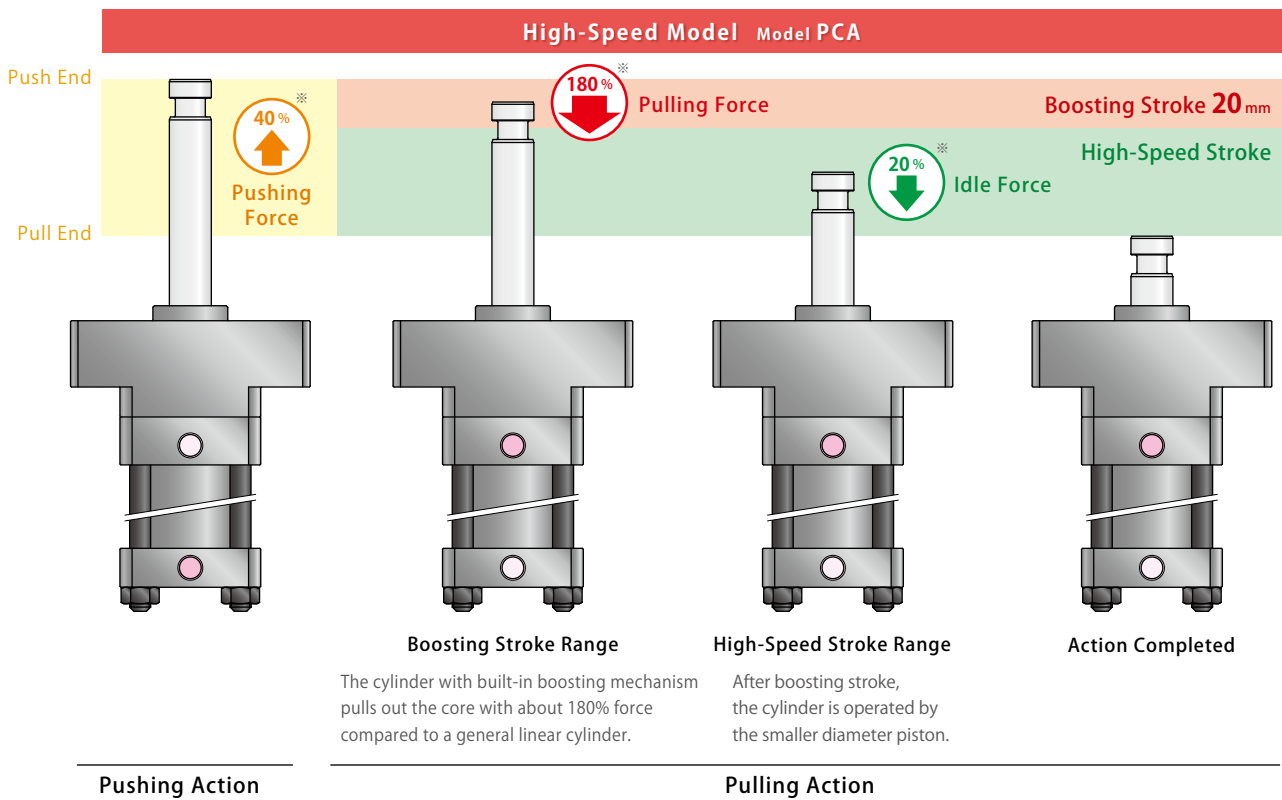

※ Ratio when compared to same-size general linear cylinder.

Select the **Standard Model (Model PCC)** when strong power is required for idle stroke on both push and pull sides.

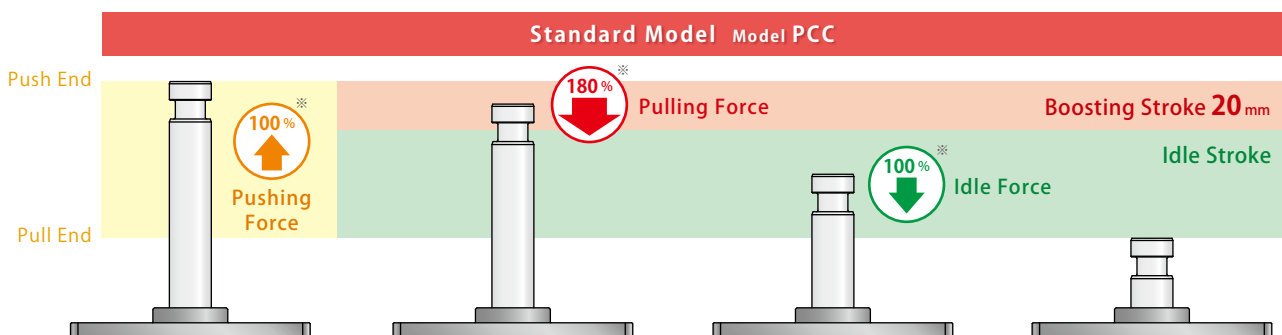

※ Ratio when compared to same-size general linear cylinder.

3 size smaller

Compared to a General Linear Cylinder

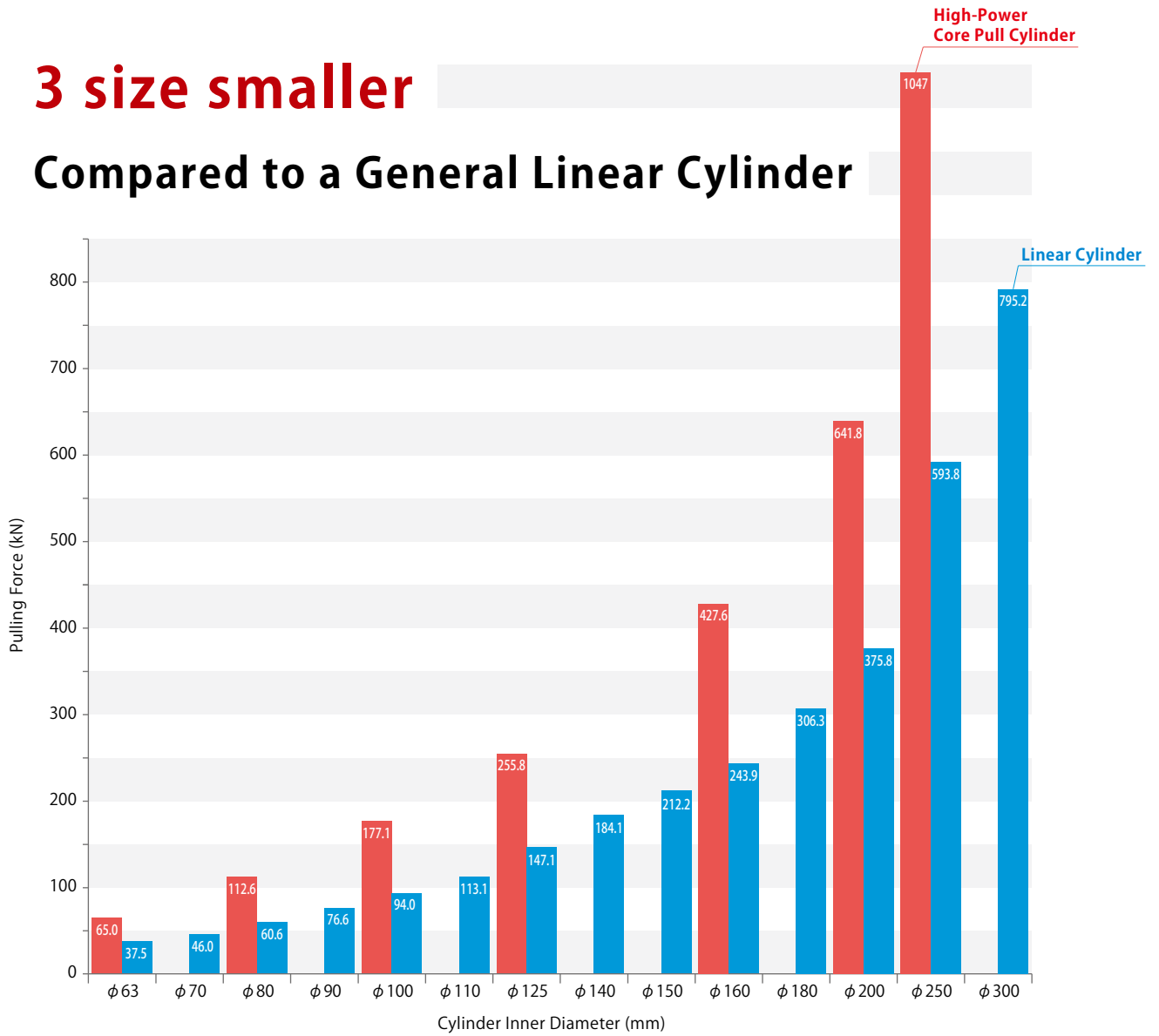

Pulling Force Comparison (Supply Hydraulic Pressure at 15MPa)

3 Size Down Example

General Linear Cylinder

Cylinder Inner Diameter φ 140 mm

Pulling Force **184.1 kN**

Weight About **80 kg**

Cylinder Weight

46% Down!

High-Power Core Pull Cylinder

Cylinder Inner Diameter φ 100 mm

Pulling Force **177.1 kN**

Weight About **43.3 kg**

※ High-Speed Model (PCA)
When stroke is 200 mm and hydraulic pressure is 15 MPa.

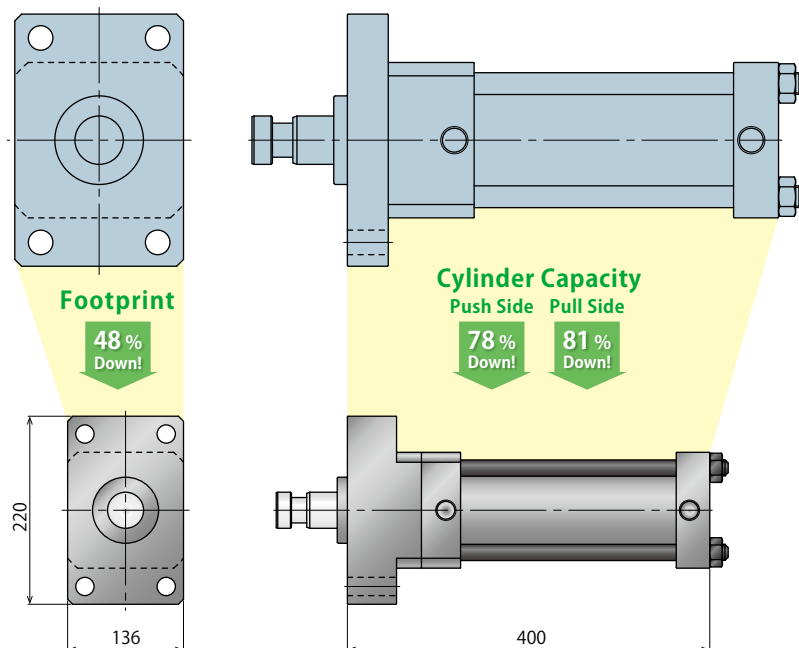

Downsizing the Core Cylinder allows for

Downsizing the Entire Mold

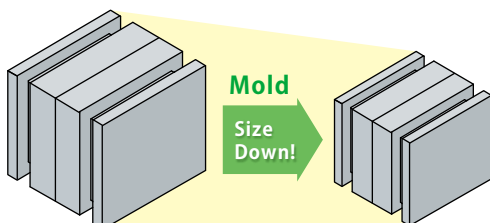

Smaller footprint of the core cylinder enables to reduce the mold size and weight.

Reducing the idle force and cylinder size enables to reduce oil amount[※] and improve operation speed, allowing for **drastic cycle time reduction**.

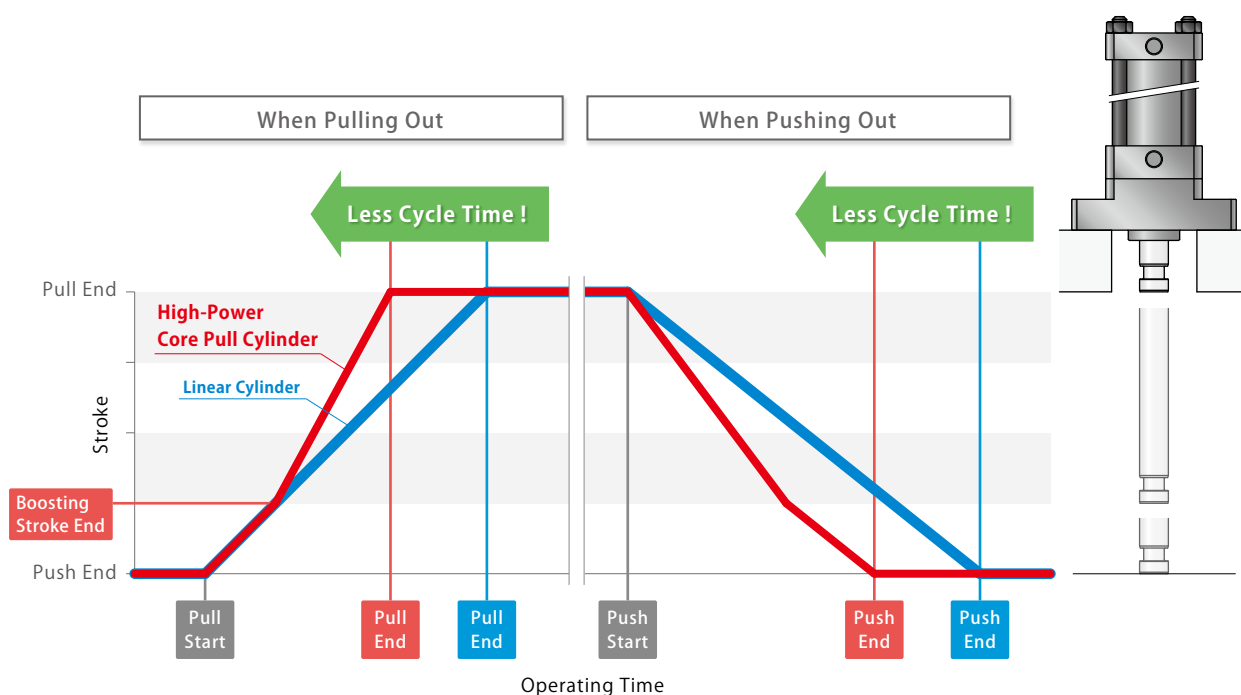

Operating Time Image (Compared to cylinder with the same pulling force.)

※ Reducing improvement of the idle force is only available for High-Speed Model (model PCA).

With the Standard Model (model PCC), the cycle time will be reduced by downsizing of the cylinder.

● Model No. Indication

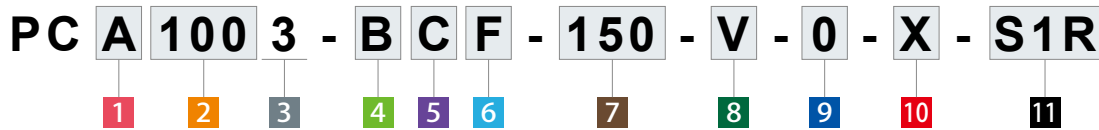

1 Operating Speed

- A : High Speed
- C : Standard

2 Cylinder Inner Diameter

- 063 : ϕ 63 mm
 - 080 : ϕ 80 mm
 - 100 : ϕ 100 mm
 - 125 : ϕ 125 mm
 - 160 : ϕ 160 mm
 - 200 : ϕ 200 mm
 - 250 : ϕ 250 mm
- Only available for 1 A : High Speed

3 Design No.

- 3 : Revision Number

4 Mounting Spigot Joint Diameter

- A : Type A
- B : Type B

※. Refer to the external dimensions on P.41 for further information.

※. Only 4 A: Type A for 2 160, 200, 250.

Mounting Spigot Joint Diam.

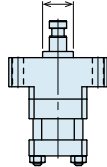

5 Rod Shape

- C : Coupling
- T : Male Thread

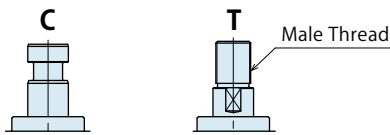

※. Only 5 C: Coupling for 2 125, 160, 200, 250.

6 Hydraulic Port Position

- F : Front
- R : Right Side
- L : Left Side

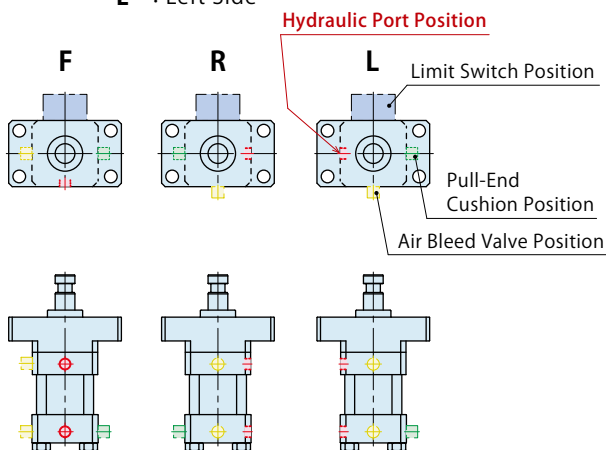

7 Stroke

40 ~ 500 : Select from Stroke 40 ~ 500mm

※. 7 Stroke differs depending on 2 Cylinder Inner Diameter. Refer to the stroke on the specifications on the next page.

※. Specify 7 Stroke in 5mm increments.

8 Operating Temperature

N : Standard 0 ~ 70 °C V : High Temp. 0 ~ 120 °C

9 Usable Fluid

- 0 : General Hydraulic Oil (Equivalent to ISO-VG-32)
- G : Water·Glycol
- S : Silicon Oil
- F : Fatty Acid Ester

※. Refer to "Appropriate Fluid According to Packing Material" on the next page for further information.

10 Option

Blank : None

X : with Air Bleed Valve

H : with Pull-End Cushion

XH : with Air Bleed Valve and Pull-End Cushion

X : with Air Bleed Valve
Able to release the air in the circuit with a wrench.

H : with Pull-End Cushion
Able to cushion at the pull end by adjusting flow rate with a wrench.

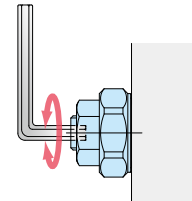
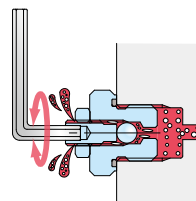

11 Limit Switch

Blank : No Limit Switch

S1R : Standard Model } Mounting position is as shown in the below drawing.

S1L : Standard Model } Mounting position is as shown in the below drawing.

S2R : Relay Box Model } Mounting position is as shown in the below drawing.

S2L : Relay Box Model } Mounting position is as shown in the below drawing.

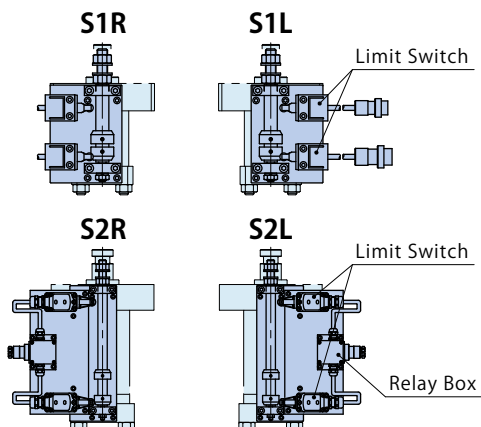

※. Refer to "Limit Switch" on P.45 for further information.

● Specifications

● PCA : High-Speed Model

Model No.		PCA0633	PCA0803	PCA1003	PCA1253	PCA1603	PCA2003	PCA2503
Cylinder Inner Diameter	mm	φ 63	φ 80	φ 100	φ 125	φ 160	φ 200	φ 250
Stroke (in 5mm increments)	mm	40 ~ 250	40 ~ 300	40 ~ 400	40 ~ 500			
Cylinder ^{※1}	Push Side	1.26×Stroke+37.2	1.96×Stroke+61.3	2.83×Stroke+100.5	4.42×Stroke+157.1	7.85×Stroke+245.0	11.31×Stroke+402.1	17.67×Stroke+628.3
	Pull Side	0.64×Stroke+73.8	0.97×Stroke+130.7	1.24×Stroke+211.3	1.95×Stroke+302.0	4.01×Stroke+490.1	4.95×Stroke+756.7	8.17×Stroke+1232.7
Capacity	cm ³							
Operating Pressure	MPa	15.0						
Max. Operating Pressure	MPa	16.0						
Min. Operating Pressure ^{※2}	MPa	1.0						
Withstanding Pressure	MPa	24.0						
Operating Temperature	°C	8 N: Standard 0 ~ 70 V: High Temperature 0 ~ 120						
Weight ^{※1}	kg	0.033×Stroke+10.0	0.053×Stroke+16.5	0.083×Stroke+26.7	0.130×Stroke+43.3	0.180×Stroke+91.4	0.293×Stroke+166.9	0.440×Stroke+273.3

● PCC : Standard Model

Model No.		PCC0633	PCC0803	PCC1003	PCC1253	PCC1603
Cylinder Inner Diameter	mm	φ 63	φ 80	φ 100	φ 125	φ 160
Stroke (in 5mm increments)	mm	40 ~ 250	40 ~ 300	40 ~ 400	40 ~ 500	
Cylinder ^{※1}	Push Side	3.12×Stroke	5.03×Stroke	7.85×Stroke	12.27×Stroke	20.11×Stroke
	Pull Side	2.50×Stroke+36.6	4.04×Stroke+69.4	6.26×Stroke+110.8	9.81×Stroke+144.9	16.26×Stroke+245.0
Capacity	cm ³					
Operating Pressure	MPa	15.0				
Max. Operating Pressure	MPa	16.0				
Min. Operating Pressure ^{※2}	MPa	1.0				
Withstanding Pressure	MPa	24.0				
Operating Temperature	°C	8 N: Standard 0 ~ 70 V: High Temperature 0 ~ 120				
Weight ^{※1}	kg	0.013×Stroke+10.0	0.022×Stroke+16.5	0.034×Stroke+26.7	0.053×Stroke+43.3	0.126×Stroke+84.8

Notes :

※1. The stroke in calculation of cylinder capacity and weight should be calculated in mm.

※2. Minimum pressure to operate the cylinder with no load.

● Appropriate Fluid According to Packing Material

8 Operating Temperature	Packing Material	Appropriate Fluid			
		O: General Hydraulic Oil	G: Water·Glycol	S: Silicon Oil	F: Fatty Acid Ester
N: Standard 0 ~ 70 °C	Nitrile Rubber (NBR)	○	○	○	○
V: High Temperature 0 ~ 120 °C	Fluor Rubber (FKM)	○	△ ^{※3}	○	○

Notes :

※3. Please contact us when using 9 G : Water · Glycol with 8 V : High Temperature.

1. Please contact us for other conditions.

High-Power
Core Push Cylinder

High-Speed
Core Pull Cylinder

High-Speed
Core Pull Cylinder
Compact Model

High-Power
Core Pull Cylinder

Flat Cylinder

● Cylinder Thrust Force

● PCA : High-Speed Model

Model No.		PCA0633	PCA0803	PCA1003	PCA1253	PCA1603	PCA2003	PCA2503	
Pushing Force	at P: 15MPa	18.8	29.5	42.4	66.3	117.8	169.6	265.1	
	Calculation Formula ^{※1}	$F_1=1.26 \times P$	$F_1=1.96 \times P$	$F_1=2.83 \times P$	$F_1=4.42 \times P$	$F_1=7.85 \times P$	$F_1=11.31 \times P$	$F_1=17.67 \times P$	
Pull Side	Pulling Force (Push End ~ 20mm)	at P: 15MPa	65.0	112.6	177.1	255.8	427.6	641.8	1047.0
		Calculation Formula ^{※1}	$F_2=4.33 \times P$	$F_2=7.51 \times P$	$F_2=11.81 \times P$	$F_2=17.05 \times P$	$F_2=28.51 \times P$	$F_2=42.79 \times P$	$F_2=69.80 \times P$
	Idle Force (20mm ~ Pull End)	at P: 15MPa	9.6	14.6	18.6	29.3	60.1	74.2	122.5
		Calculation Formula ^{※1}	$F_3=0.64 \times P$	$F_3=0.97 \times P$	$F_3=1.24 \times P$	$F_3=1.95 \times P$	$F_3=4.01 \times P$	$F_3=4.95 \times P$	$F_3=8.17 \times P$

● PCC : Standard Model

Model No.		PCC0633	PCC0803	PCC1003	PCC1253	PCC1603	
Pushing Force	at P: 15MPa	46.8	75.4	117.8	184.1	301.6	
	Calculation Formula ^{※1}	$F_1=3.12 \times P$	$F_1=5.03 \times P$	$F_1=7.85 \times P$	$F_1=12.27 \times P$	$F_1=20.11 \times P$	
Pull Side	Pulling Force (Push End ~ 20mm)	at P: 15MPa	65.0	112.6	177.1	255.8	427.6
		Calculation Formula ^{※1}	$F_2=4.33 \times P$	$F_2=7.51 \times P$	$F_2=11.81 \times P$	$F_2=17.05 \times P$	$F_2=28.51 \times P$
	Idle Force (20mm ~ Pull End)	at P: 15MPa	37.5	60.6	94.0	147.1	243.9
		Calculation Formula ^{※1}	$F_3=2.50 \times P$	$F_3=4.04 \times P$	$F_3=6.26 \times P$	$F_3=9.81 \times P$	$F_3=16.26 \times P$

Note :

※1. F_1 : Pushing Force (kN), F_2 : Pulling Force (kN), F_3 : Idle Force (kN), P : Hydraulic Pressure (MPa)

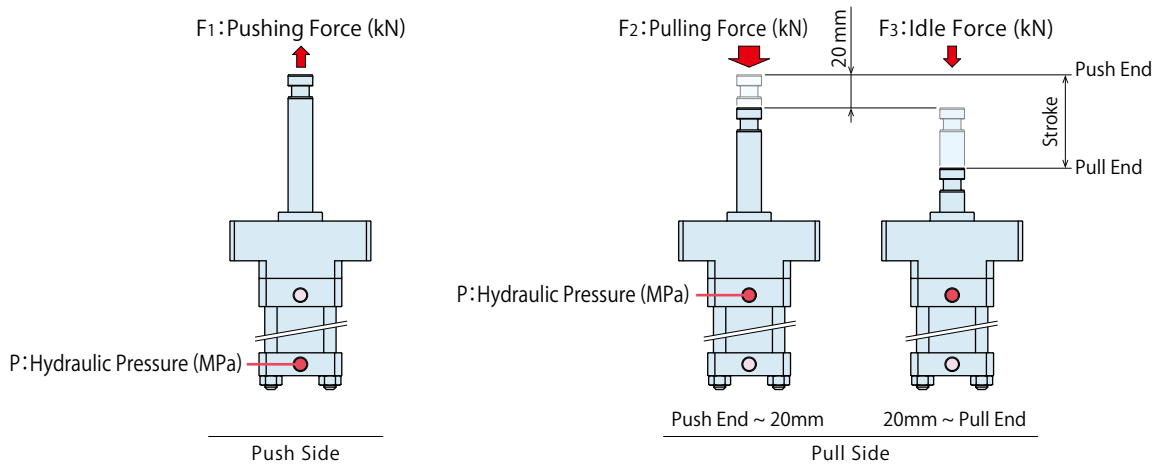

High-Power
Core Push Cylinder

High-Speed
Core Pull Cylinder

High-Speed
Core Pull Cylinder
Compact Model

High-Power
Core Pull Cylinder

Flat Cylinder

External Dimensions : Cylinder Inner Diameter 063 ~ 200

※ This drawing shows the pull end state of PCA0633 ~ PCA2003, PCC0633 ~ PCC1603. External dimensions of PCA and PCC are the same.

Rod Shape C : Coupling, Port Position F : Front, Option Blank : None

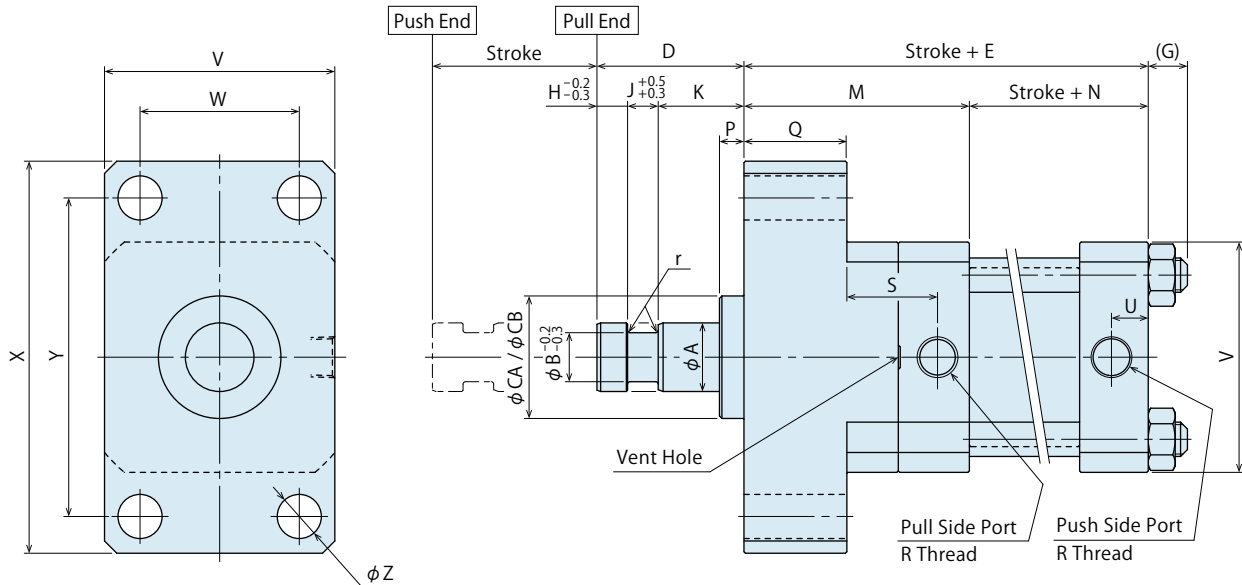

Rod Shape C : Coupling, Port Position F : Front,

Option X : with Air Bleed Valve,

Option H : with Pull-End Cushion, Option XH : with Air Bleed Valve and Pull-End Cushion

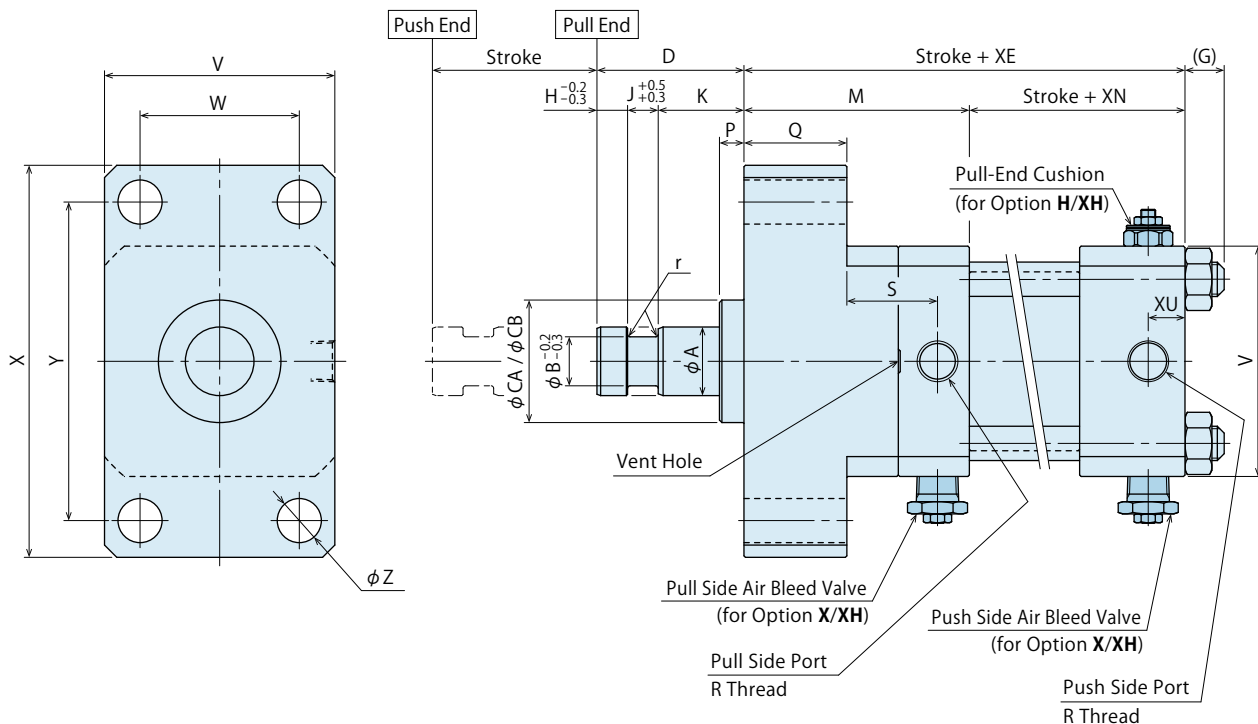

Rod Shape T : Male Thread

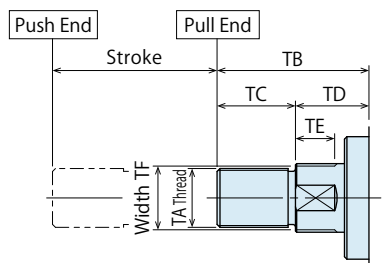

Port Position F : Front

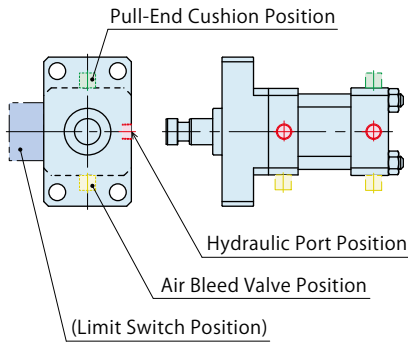

Port Position R : Right Side

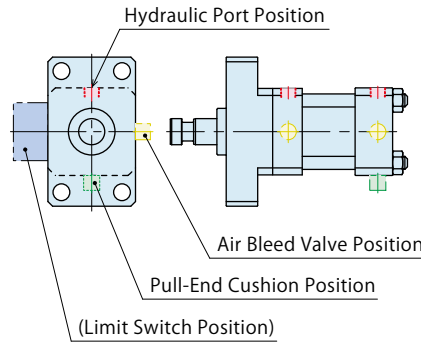

Port Position L : Left Side

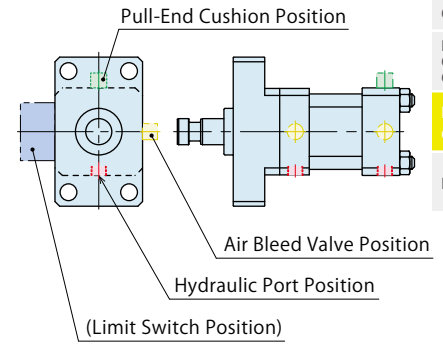

- High-Power Core Push Cylinder
- High-Speed Core Pull Cylinder
- High-Speed Core Pull Cylinder Compact Model
- High-Power Core Pull Cylinder
- Flat Cylinder

External Dimension List

- Rod Shape **C** : Coupling, Option **Blank** : None

Model No.	PCA0633-C PCC0633-C	PCA0803-C PCC0803-C	PCA1003-C PCC1003-C	PCA1253-C PCC1253-C	PCA1603-C PCC1603-C	PCA2003-C
A	28 $f7^{-0.020}_{-0.041}$	35.5 $f7^{-0.025}_{-0.050}$	45 $f7^{-0.025}_{-0.050}$	56 $f7^{-0.030}_{-0.060}$	70 $f7^{-0.030}_{-0.060}$	90 $f7^{-0.036}_{-0.071}$
B	20	25	31	38	49	60
CA (Mounting Spigot Joint Diam. A)	43 $f7^{-0.025}_{-0.050}$	52 $f7^{-0.030}_{-0.060}$	62 $f7^{-0.030}_{-0.060}$	72 $f8^{-0.030}_{-0.076}$	105 $f8^{-0.036}_{-0.090}$	125 $f8^{-0.043}_{-0.106}$
CB (Mounting Spigot Joint Diam. B)	50 $f7^{-0.025}_{-0.050}$	65 $f7^{-0.030}_{-0.060}$	70 $f7^{-0.030}_{-0.060}$	85 $f8^{-0.036}_{-0.090}$	-	-
D	60	70	75	90	115	130
E	165	180	200	220	270	305
G	16	18	22	25	30	37
H	12.5	15	15	20	25	30
J	12.5	15	15	20	25	30
K	35	40	45	50	65	70
M	92	100	110	125	145	165
N	73	80	90	95	125	140
P	10	10	10	10	10	10
Q	42	45	55	60	75	85
R	Rc3/8	Rc3/8	Rc1/2	Rc1/2	Rc3/4	Rc3/4
S	37	40	38.5	45	45	55
U	12.5	16	19	24	31	41
V	94	114	136	165	212	278
W	65	80	100	125	160	210
X	160	185	220	255	335	405
Y	130	150	180	210	275	335
Z	18	18	22	26	33	39
r	R1	R1.5	R2	R2	R3.5	R5
Mounting Bolt	M16×2	M16×2	M20×2.5	M24×3	M30×3.5	M36×4

- Option **X** : with Air Bleed Valve, **H** : with Pull-End Cushion, **XH** : with Air Bleed Valve and Pull-End Cushion

Unlisted dimensions are the same with Option **Blank** : None.

Model No.	PCA0633-□-X/H/XH PCC0633-□-X/H/XH	PCA0803-□-X/H/XH PCC0803-□-X/H/XH	PCA1003-□-X/H/XH PCC1003-□-X/H/XH	PCA1253-□-X/H/XH PCC1253-□-X/H/XH	PCA1603-□-X/H/XH PCC1603-□-X/H/XH	PCA2003-□-X/H/XH
XE	180	195	215	235	285	320
XN	88	95	105	110	140	155
XU	15	19	22	21	31	41

- Rod Shape **T** : Male Thread

(mm)

Model No.	PCA0633-T PCC0633-T	PCA0803-T PCC0803-T	PCA1003-T PCC1003-T
TA	M24×1.5	M30×1.5	M40×1.5
TB	62	66	80
TC	32	36	45
TD	30	30	35
TE	16	17	22
TF	26	32	41

External Dimensions : Cylinder Inner Diameter 250

※ This drawing shows the pull end state of PCA2503.

Rod Shape C : Coupling, Port Position F : Front, Option Blank : None

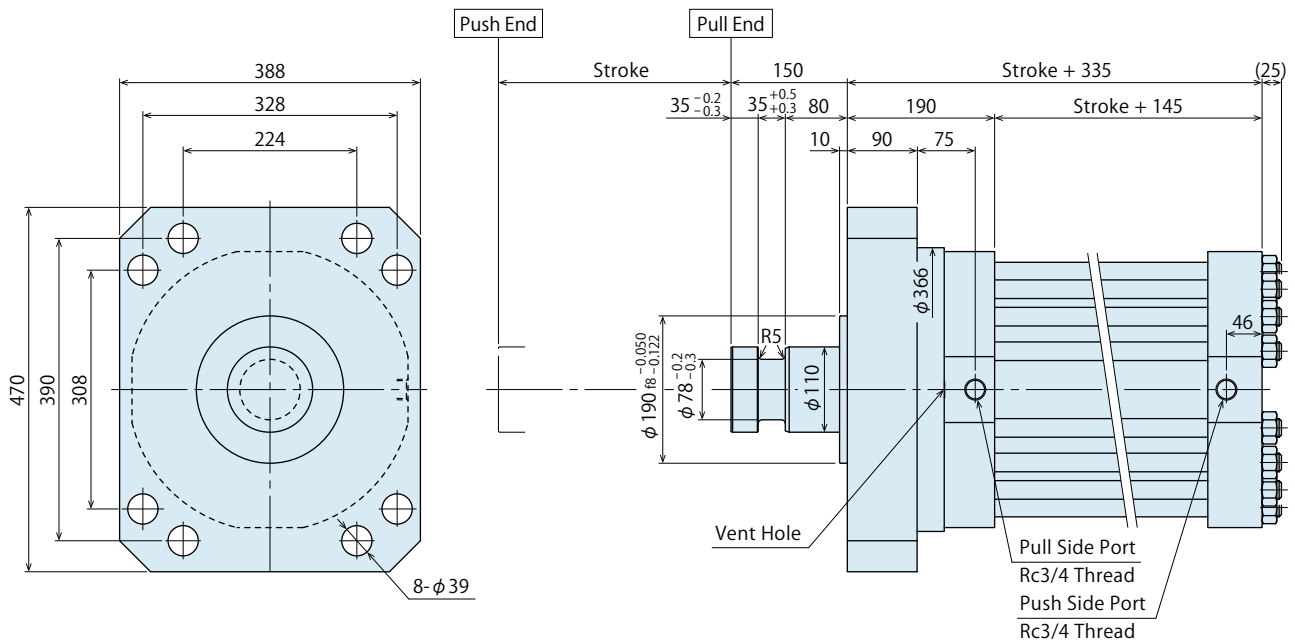

Rod Shape C : Coupling, Port Position F : Front,

Option X : with Air Bleed Valve,

Option H : with Pull-End Cushion, Option XH : with Air Bleed Valve and Pull-End Cushion

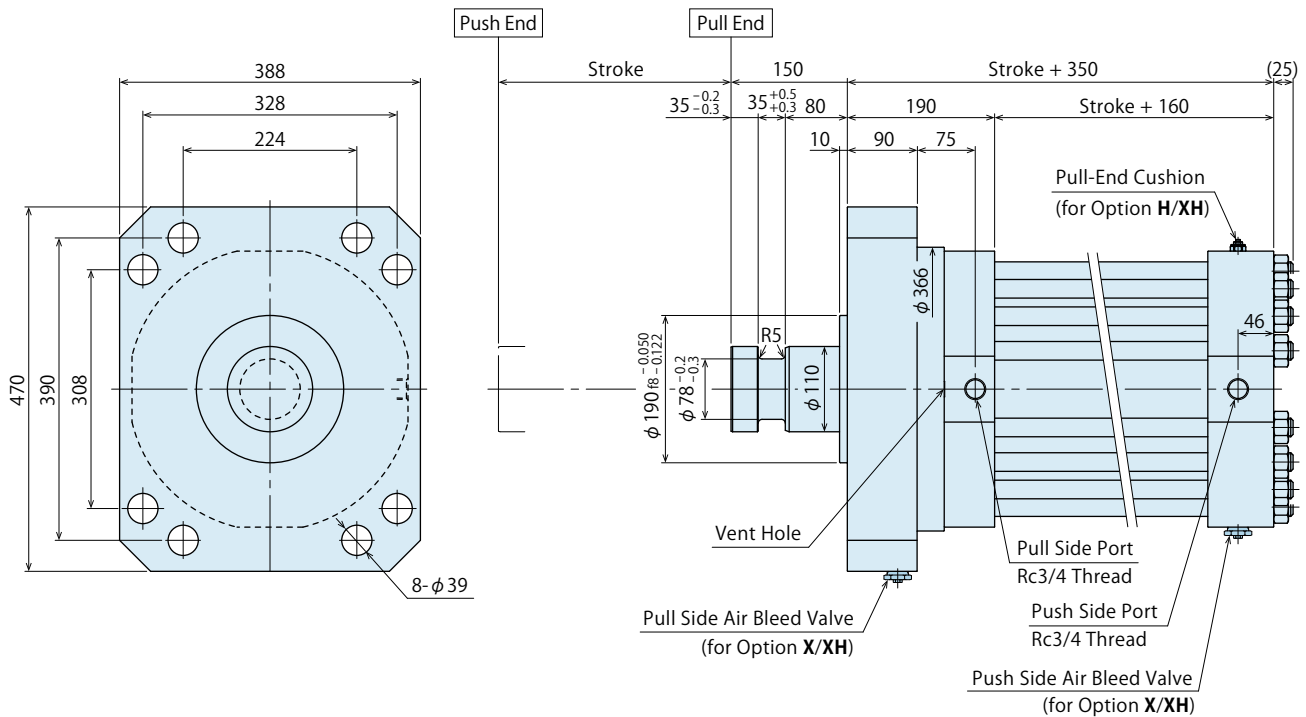

Port Position **F** : Front

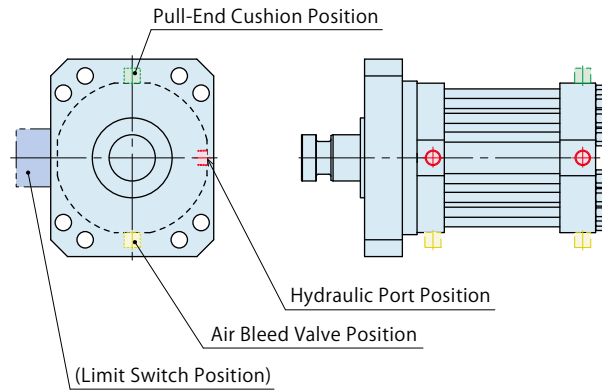

Port Position **R** : Right Side

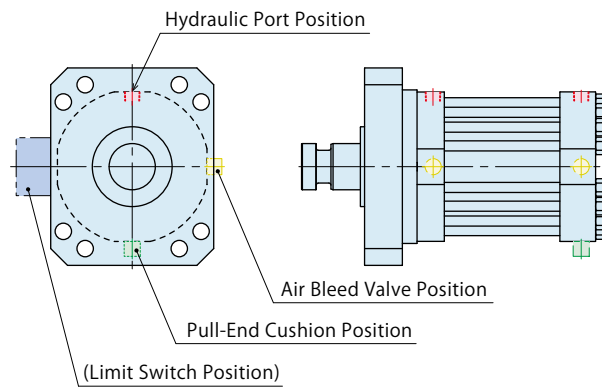

Port Position **L** : Left Side

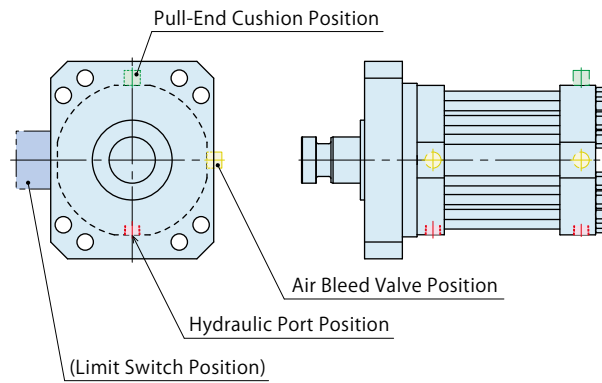
 High-Power
 Core Push Cylinder

 High-Speed
 Core Pull Cylinder

 High-Speed
 Core Pull Cylinder
 Compact Model

 High-Power
 Core Pull Cylinder

Flat Cylinder

● Limit Switch



● Action Description

※ This drawing shows the standard model.

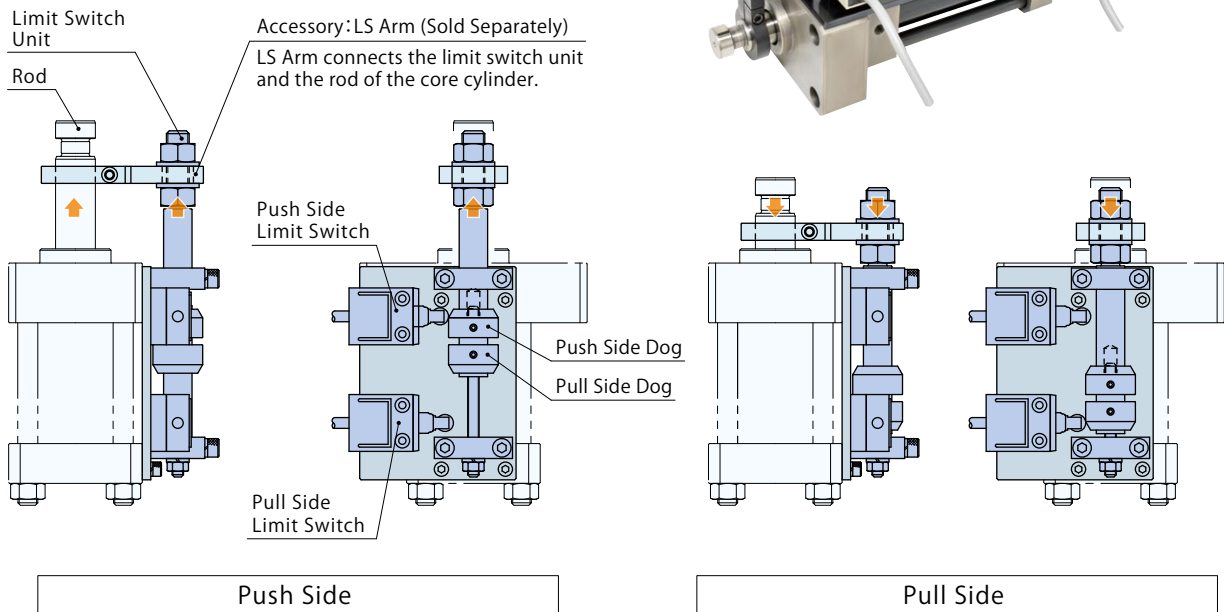

● Limit Switch Applicable List

Model No.	PCE	PCB	PCM	PCA/PCC
S1□ : Standard Model		○		○
S2□ : Relay Box Model		○		○
S3 : Compact Model	○		○	

● Limit Switch : Relay Box Model

Model No. Indication

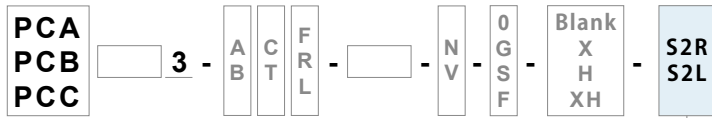

When selecting Limit Switch S2R / S2L

Specifications

Limit Switch Model No.	5LS1-J (Made by Azbil)
Cable Specification	VCTF Oil-Resistant Cable
Operating Temperature	-10 ~ 70°C
Protection Level	IP67

※. Refer to maker's specifications for the detail of the limit switch.

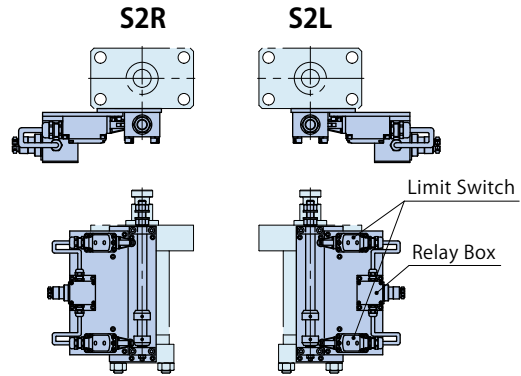

External Dimensions

- ※ This drawing shows when cylinder total length is $L \leq 225$.
- ※ This drawing shows dimensions when selecting S2R.

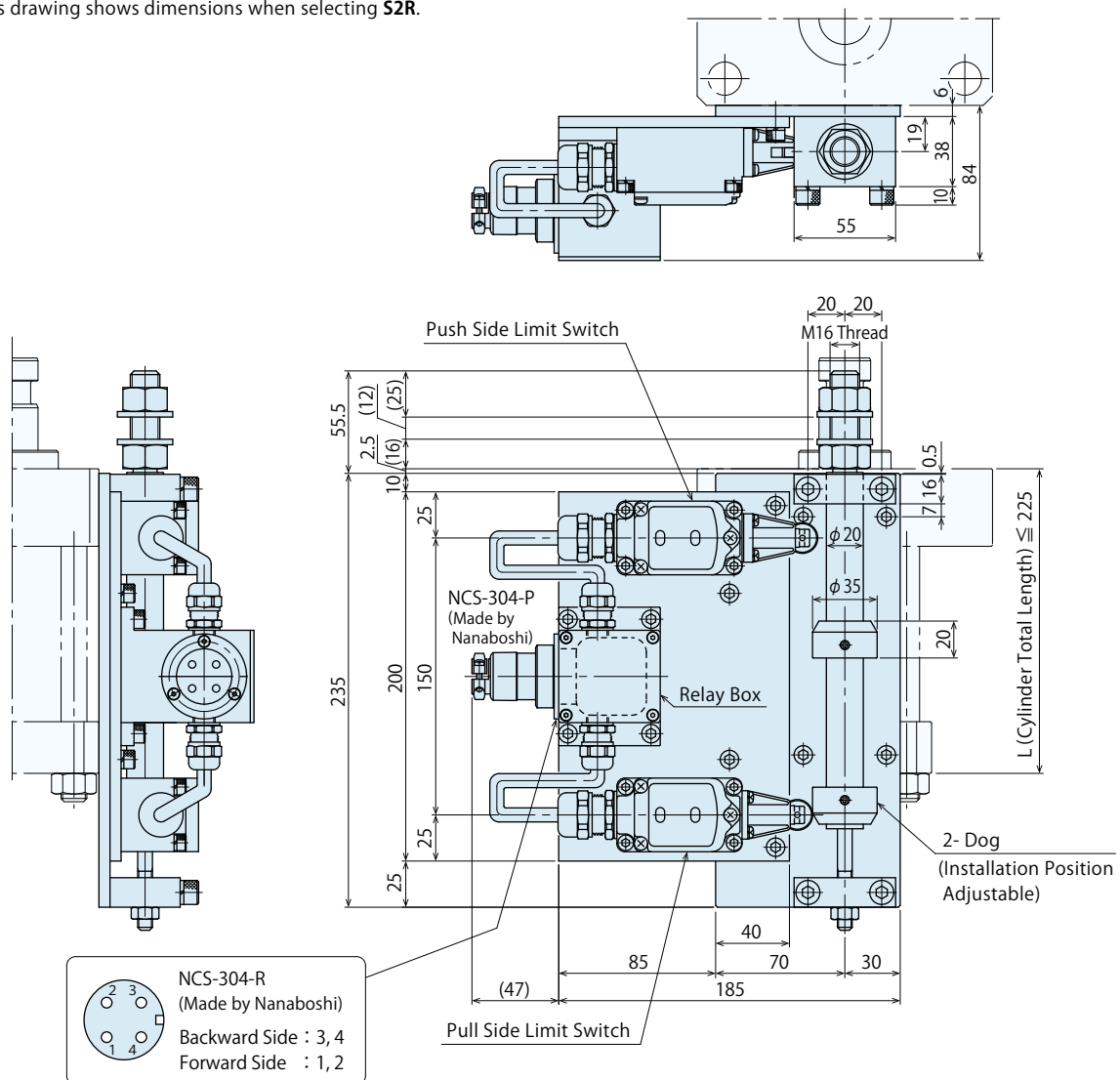

※ This drawing shows when cylinder total length is $L \geq 230$.

※ This drawing shows dimensions when selecting **S2R**.

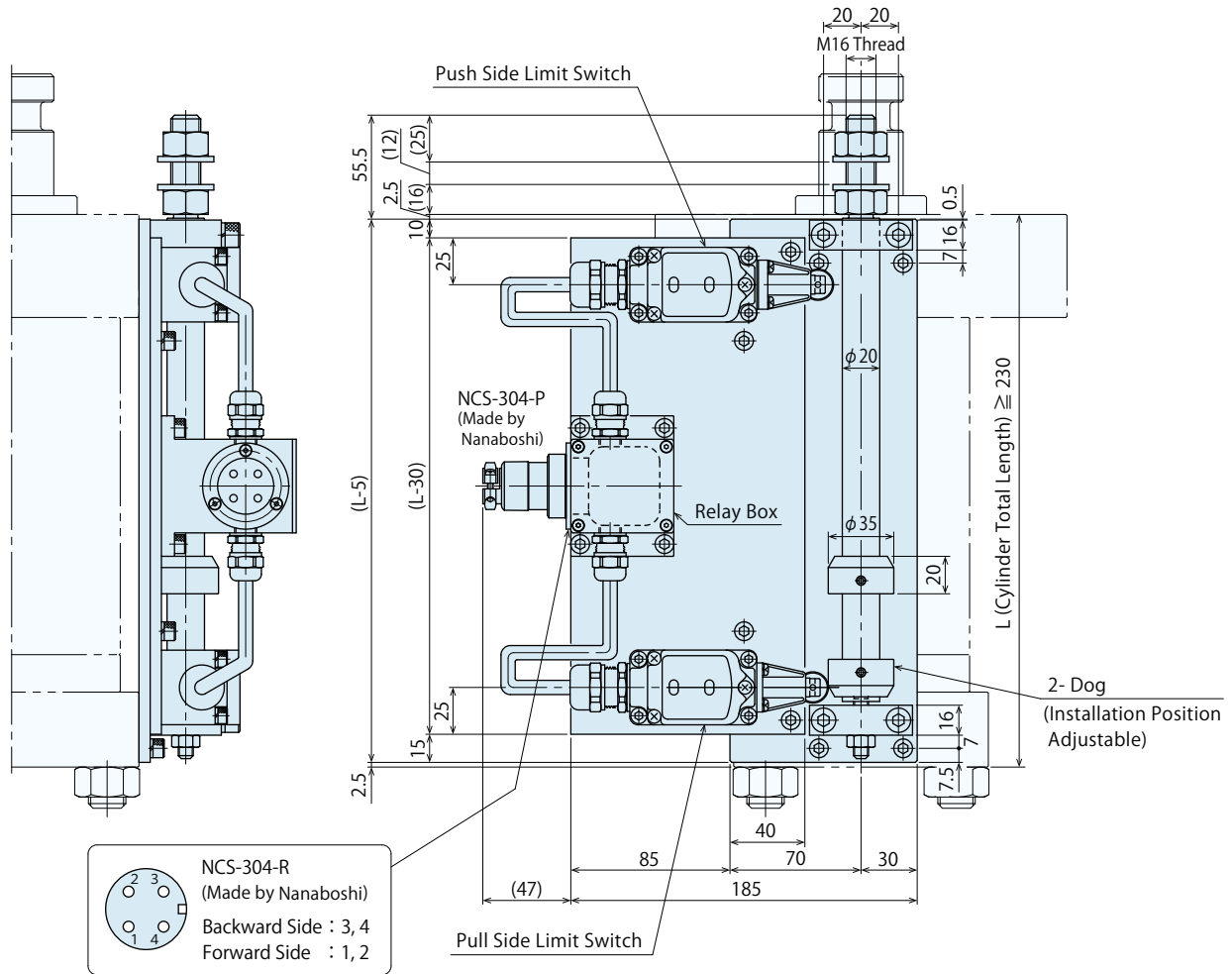
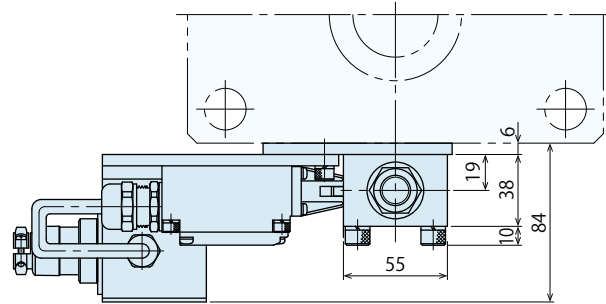

● Accessory for Limit Switch : LS Arm

● LS Arm for S1/S2 Limit Switch Unit

The arm to connect S1/S2 limit switch unit and the rod of PCA/PCB/PCC cylinder.

Model No. : **PCZ0630-A**

Applicable Models

PCA0633-S1/PCA0633-S2
PCB0633-S1/PCB0633-S2
PCC0633-S1/PCC0633-S2

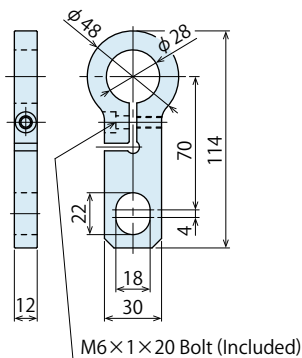

Model No. : **PCZ0800-A**

Applicable Models

PCA0803-S1/PCA0803-S2
PCB0803-S1/PCB0803-S2
PCC0803-S1/PCC0803-S2

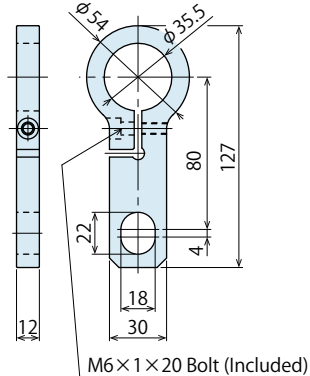

Model No. : **PCZ1000-A**

Applicable Models

PCA1003-S1/PCA1003-S2
PCB1003-S1/PCB1003-S2
PCC1003-S1/PCC1003-S2

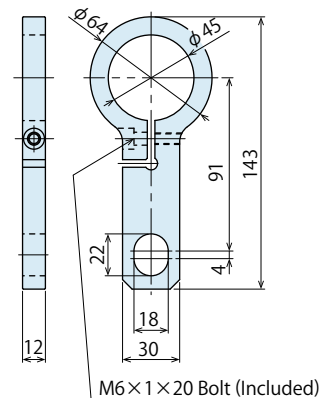

Model No. : **PCZ1250-A**

Applicable Models

PCA1253-S1/PCA1253-S2
PCB1253-S1/PCB1253-S2
PCC1253-S1/PCC1253-S2

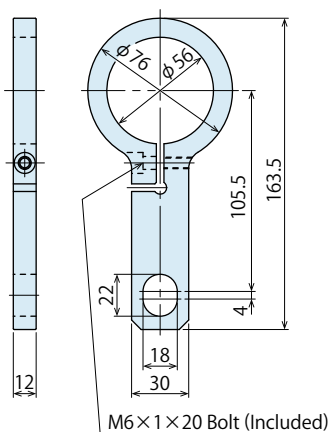

Model No. : **PCZ1600-A**

Applicable Models

PCA1603-S1/PCA1603-S2
PCB1603-S1/PCB1603-S2
PCC1603-S1/PCC1603-S2

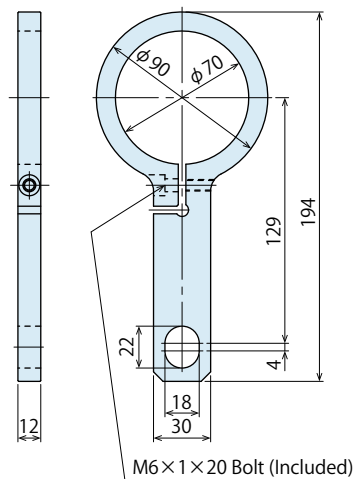

Model No. : **PCZ2000-A**

Applicable Models

PCA2003-S1/PCA2003-S2
PCB2003-S1/PCB2003-S2

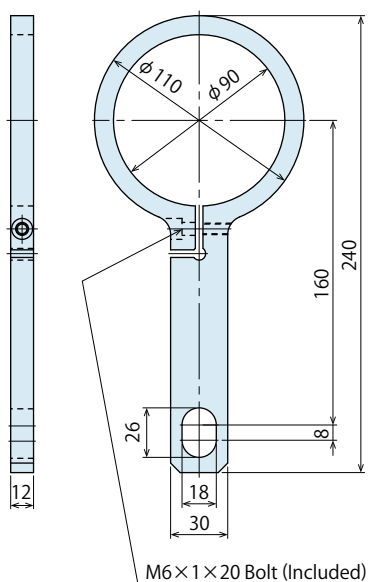

Model No. : **PCZ2500-A**

Applicable Models

PCA2503-S1/PCA2503-S2
PCB2503-S1/PCB2503-S2

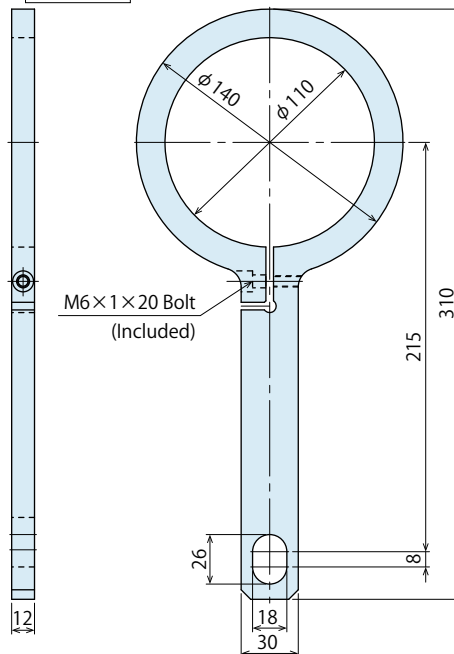

High-Power
Core Push Cylinder

High-Speed
Core Pull Cylinder

High-Speed
Core Pull Cylinder
Compact Model

High-Power
Core Pull Cylinder

Flat Cylinder

● LS Arm for S3 Limit Switch Unit

The arm to connect S3 limit switch unit and the rod of PCE/PCM cylinder.

Model No. : **PCZ0400-E**

Applicable Models PCE0400-S3
PCM0400-S3

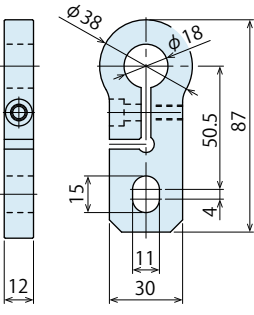

Model No. : **PCZ0500-E**

Applicable Model PCM0500-S3

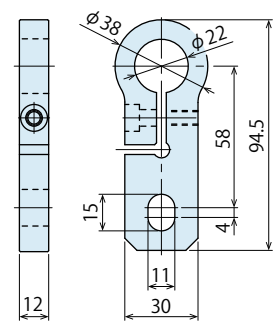

Model No. : **PCZ0630-E**

Applicable Model PCE0630-S3

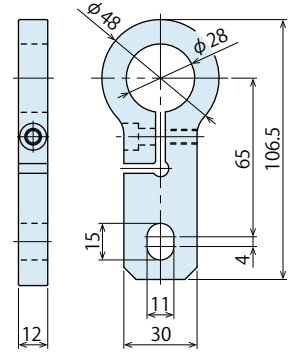

Model No. : **PCZ0800-E**

Applicable Model PCE0800-S3

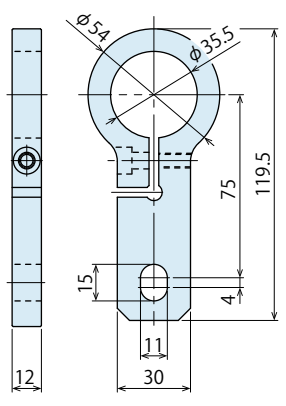

Model No. : **PCZ1000-E**

Applicable Model PCE1000-S3

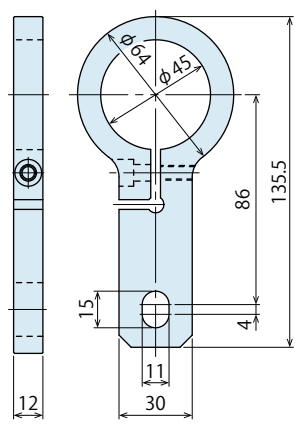

Model No. : **PCZ1250-E**

Applicable Model PCE1250-S3

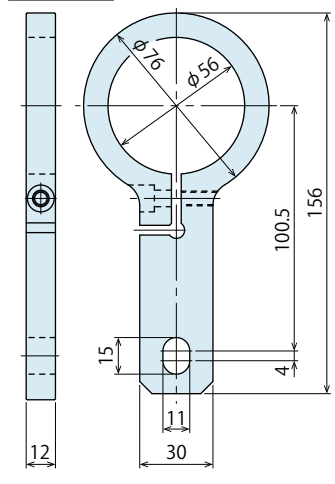

● Tapped Hole Position for Hanging Bolt

- Corresponding Model No. : Cylinder Inner Diameter **080 ~ 200**

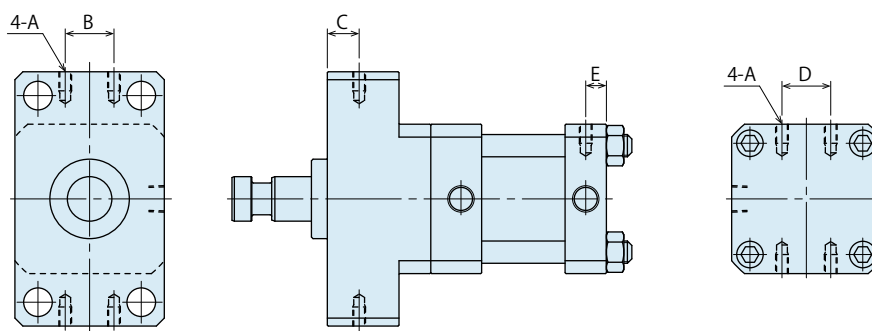

(mm)

Corresponding Model No.	PCA0803 PCB0803 PCC0803	PCA1003 PCB1003 PCC1003	PCA1253 PCB1253 PCC1253	PCA1603 PCB1603 PCC1603	PCA2003 PCB2003
A (Nominal×Pitch×Depth)	M8×1.25×15	M10×1.5×19	M12×1.75×23	M16×2×28	M16×2×28
B	40	50	60	70	100
C	20	25	25	30	45
D	40	56	70	90	120
E	10	12	12	16	16

(mm)

Corresponding Model No.	PCE0800	PCE1000	PCE1250
A (Nominal×Pitch×Depth)	M8×1.25×15	M10×1.5×19	M12×1.75×23
B	40	50	60
C	20	25	25
D	40	50	70
E	20	15	15

- Corresponding Model No. : Cylinder Inner Diameter **250 (PCA2503/PCB2503)**

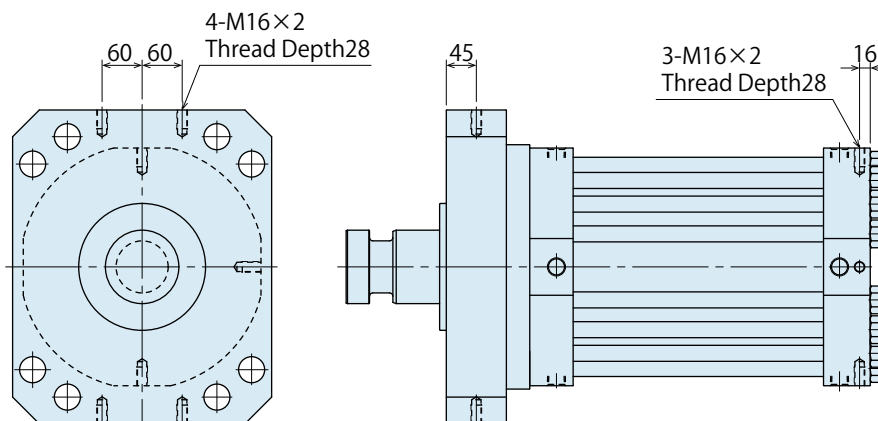

Note:

1. No tapped holes for hanging bolt are provided for cylinder inner diameter **040, 050, 063**.

 High-Power
 Core Push Cylinder

 High-Speed
 Core Pull Cylinder

 High-Speed
 Core Pull Cylinder
 Compact Model

 High-Power
 Core Pull Cylinder

Flat Cylinder

For Diecast Systems

Flat Cylinder

Model PCD

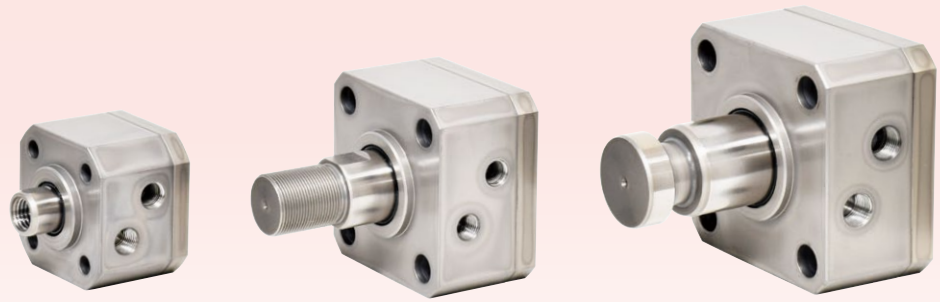

Compact Body Designed for Built-in Mold Cylinder

Suitable for Partial Pressurization, and Opening/Closing a Vent Valve

PAT.P.

The Compact Cylinder, Can be Installed in the Mold

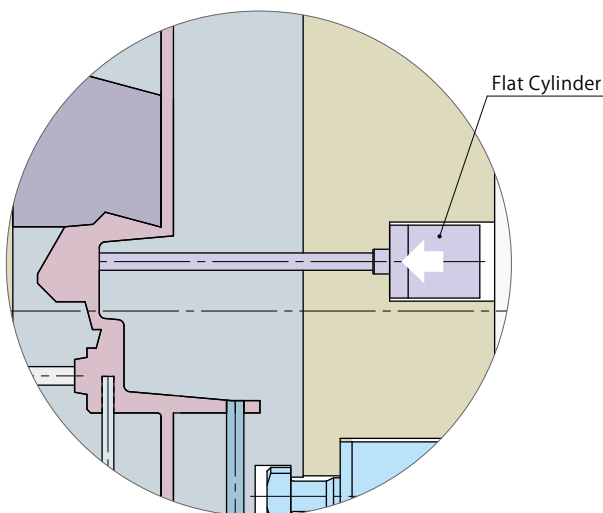

For Partial Pressurization Cylinder,
Squeeze Cylinder

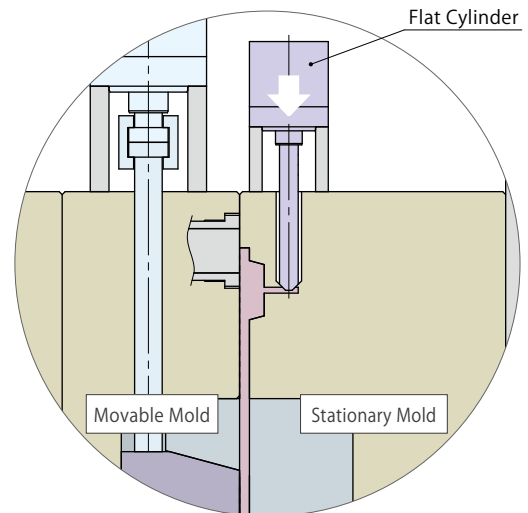

As a Cylinder for Opening/
Closing a Vent Valve

Auto Circulating model enables **air bleeding** and **cooling**, suitable for partial pressurization.

Required Points of Partial Pressurization Cylinder

A cylinder for partial pressurization is installed near the cavity inside mold, so it is easy to become high temperature during operation. Also, the timing of pressurization is very important for this cylinder, since it will cause knocking and/or action delay if air is mixed in oil leading to low quality of products.

Auto Circulating Cylinder

Kosmek Auto Circulating Cylinder enables air bleeding and cooling by auto circulation of hydraulic oil.

Pulling Action

At pull end, auto oil circulation by intended internal leak ensures air bleeding per cycle. Also, it supplies cooled oil from outside all the time, thus sealing life span will be longer.

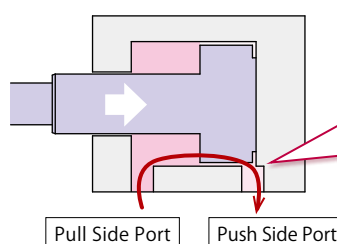
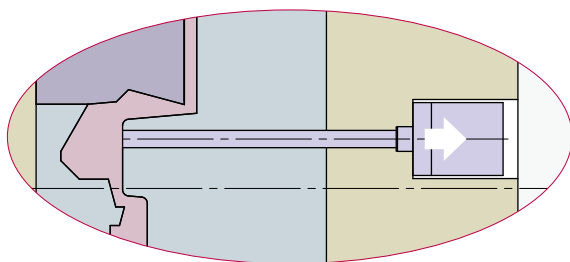

At pull end, hydraulic oil circulates automatically from the pull side port to the push side port to release the mixed air.

Pushing Action

Air bleeding of hydraulic oil per cycle prevents knocking and/or action delay, and ensures pushing action at the right time.

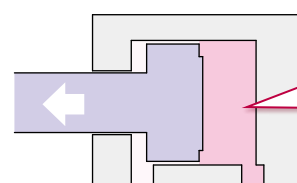
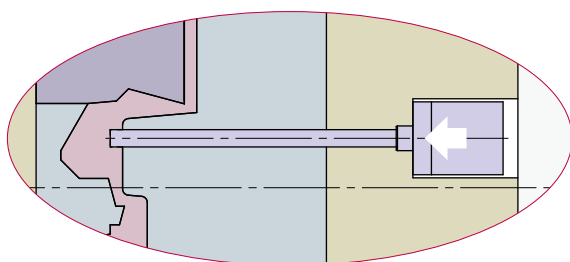

Hydraulic fluid with no air mixed ensures pushing action at the right time.

Model No. Indication

PCD **040** **0** - **A** - **015** - **N** - **0** - **J** - **S2**

1 2 3 4 5 6 7 8

1 Cylinder Inner Diameter

040 : ϕ 40 mm

063 : ϕ 63 mm

080 : ϕ 80 mm

2 Design No.

0 : Revision Number

3 Rod Shape

A : Female Thread

C : Coupling

T : Male Thread

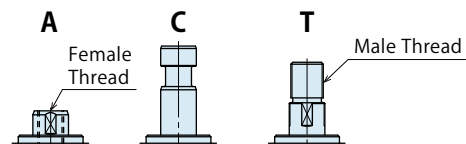

4 Stroke

010 ~ 080 : Select from Stroke 10 ~ 80 mm

※. Specify **4** Stroke in 5mm increments.

5 Operating Temperature

N : Standard 0 ~ 70 °C

V : High Temperature 0 ~ 120 °C

6 Usable Fluid

0 : General Hydraulic Oil (Equivalent to ISO-VG-32)

G : Water•Glycol

S : Silicon Oil

F : Fatty Acid Ester

※. Refer to "Appropriate Fluid According to Packing Material" on the next page for further information.

7 Auto Circulation

Blank : None

J : with Auto Circulation

8 Option

Blank : None

S1 : with Backward End Confirmation Switch

S2 : with Magnetostrictive Sensor

Specifications

Model No.		PCD0400	PCD0630	PCD0800
Cylinder Inner Diameter	mm	φ 40	φ 63	φ 80
Stroke (in 5mm increments)	mm	10 ~ 80		
Cylinder ^{※1}	Push Side	1.257×Stroke	3.117×Stroke	5.026×Stroke
	Pull Side	0.877×Stroke	2.127×Stroke	3.436×Stroke
Capacity	cm ³			
Operating Pressure	MPa	15.0		
Max. Operating Pressure	MPa	16.0		
Min. Operating Pressure ^{※2}	MPa	1.0		
Withstanding Pressure	MPa	24.0		
Operating Temperature	°C	5 N : Standard 0 ~ 70 V : High Temperature 0 ~ 120		
Weight ^{※1}	kg	0.031×Stroke+1.6	0.052×Stroke+3.3	0.074×Stroke+5.6

Notes :

- ※1. The stroke in calculation of cylinder capacity and weight should be calculated in mm.
- ※2. Minimum pressure to operate the cylinder with no load.

Appropriate Fluid According to Packing Material

5 Operating Temperature	Packing Material	Appropriate Fluid			
		O: General Hydraulic Oil	G: Water·Glycol	S: Silicon Oil	F: Fatty Acid Ester
N : Standard 0 ~ 70 °C	Nitrile Rubber (NBR)	○	○	○	○
V : High Temperature 0 ~ 120 °C	Fluor Rubber (FKM)	○	△ ^{※3}	○	○

Notes :

- ※3. Please contact us when using **6 G** : Water · Glycol with **5 V** : High Temperature.
- 1. Please contact us for other conditions.

Cylinder Thrust Force

(kN)

Model No.		PCD0400	PCD0630	PCD0800
Pushing Force	at P: 15MPa	18.8	46.8	75.4
	Calculation Formula ^{※4}	$F_1=1.26 \times P$	$F_1=3.12 \times P$	$F_1=5.03 \times P$
Pulling Force	at P: 15MPa	13.1	31.9	51.5
	Calculation Formula ^{※4}	$F_2=0.88 \times P$	$F_2=2.13 \times P$	$F_2=3.44 \times P$

Note :

- ※4. F_1 : Pushing Force (kN), F_2 : Pulling Force (kN), P : Hydraulic Pressure (MPa)

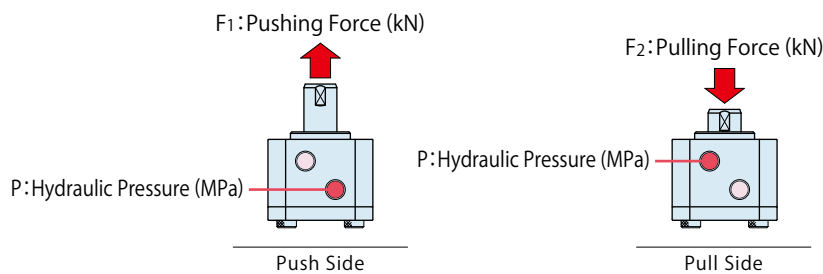

High-Power
Core Push Cylinder

High-Speed
Core Pull Cylinder

High-Speed
Core Pull Cylinder
Compact Model

High-Power
Core Pull Cylinder

Flat Cylinder

External Dimensions : Option Blank

※ This drawing shows the pull end state of PCD.

Rod Shape A : Female Thread

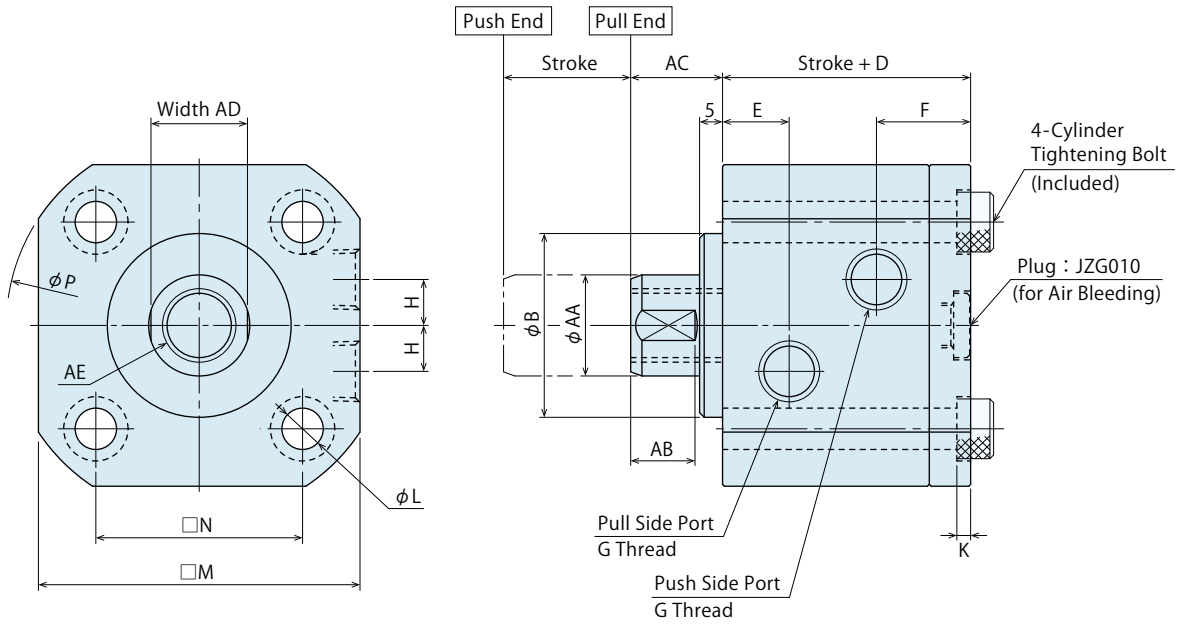

Rod Shape C : Coupling

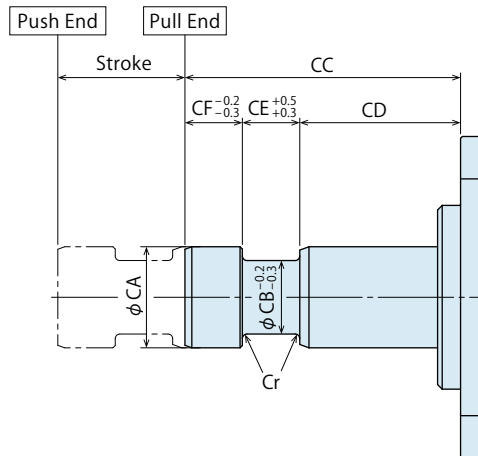

Rod Shape T : Male Thread

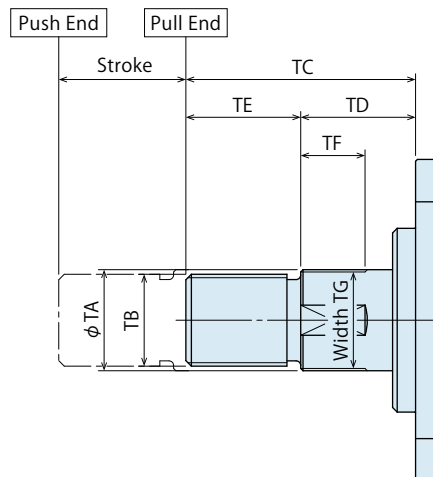

External Dimension List : Option Blank

● Cylinder Body Part

(mm)

Model No.	PCD0400	PCD0630	PCD0800
B	40 $f7_{-0.025}^{-0.050}$	52 $f7_{-0.030}^{-0.060}$	62 $f7_{-0.030}^{-0.060}$
D	39	47	53
E	14.5	17	18
F	20.5	24	29
G	Rc1/4	Rc1/4	Rc3/8
H	10	12	15
K	3	4	4
L	9	14	16
M	70	94	114
N	45	67	83
P	84	122	148
Cylinder Tightening Bolt	M8×1.25	M12×1.75	M14×2

● Rod Shape A : Female Thread

(mm)

Model No.	PCD0400-A	PCD0630-A	PCD0800-A
AA	22	35.5	45
AB	14	17	22
AC	20	25	30
AD	21	32	41
AE (Nominal×Pitch×Depth)	M16×2×20	M27×3×35	M30×3.5×35

● Rod Shape C : Coupling

(mm)

Model No.	PCD0400-C	PCD0630-C	PCD0800-C
CA	22	35.5	45
CB	16	25	31
CC	60	70	75
CD	35	40	45
CE	12.5	15	15
CF	12.5	15	15
Cr	R1	R1.5	R2

● Rod Shape T : Male Thread

(mm)

Model No.	PCD0400-T	PCD0630-T	PCD0800-T
TA	22	35.5	45
TB	M20×1.5	M30×1.5	M40×1.5
TC	50	66	80
TD	25	30	35
TE	25	36	45
TF	14	17	22
TG	21	32	41

High-Power
Core Push CylinderHigh-Speed
Core Pull CylinderHigh-Speed
Core Pull Cylinder
Compact ModelHigh-Power
Core Pull Cylinder

Flat Cylinder

External Dimensions : Option S1 with Backward End Confirmation Switch

※ This drawing shows the pull end state of PCD-S1.

Rod Shape A : Female Thread

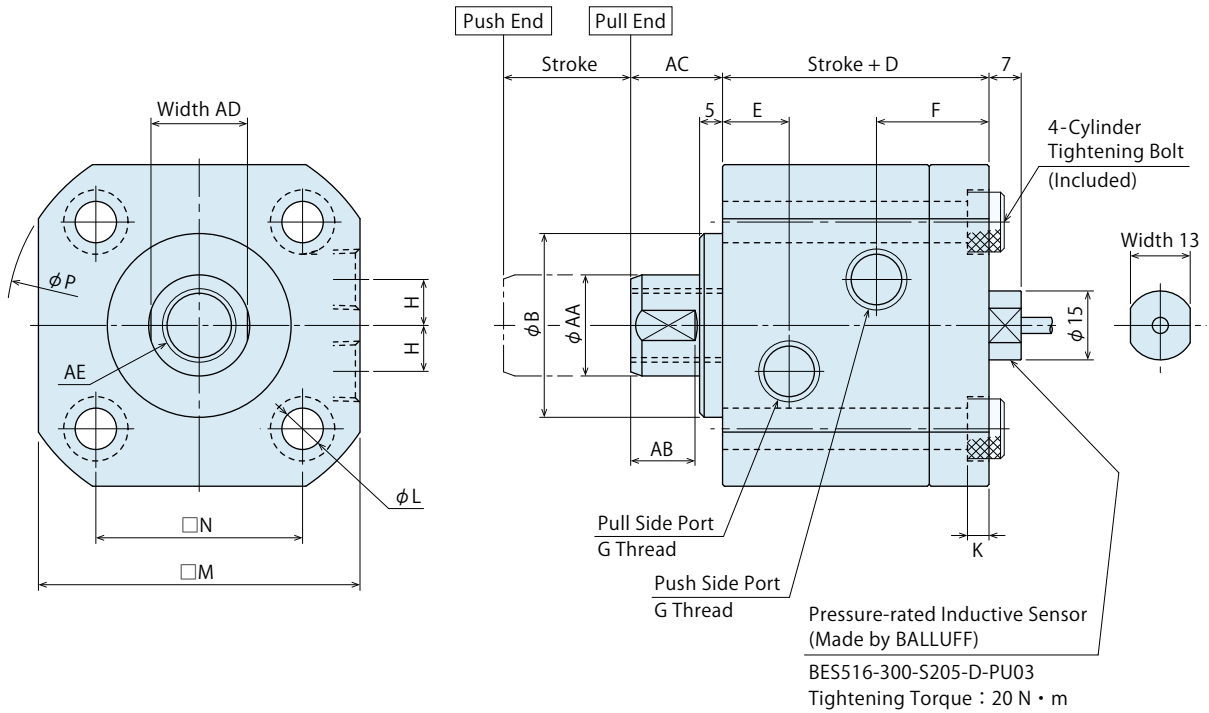

Rod Shape C : Coupling

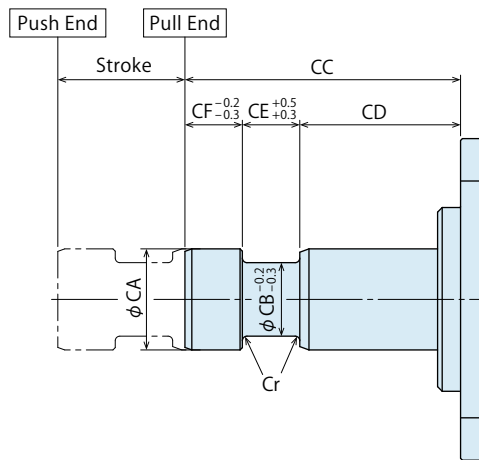

Rod Shape T : Male Thread

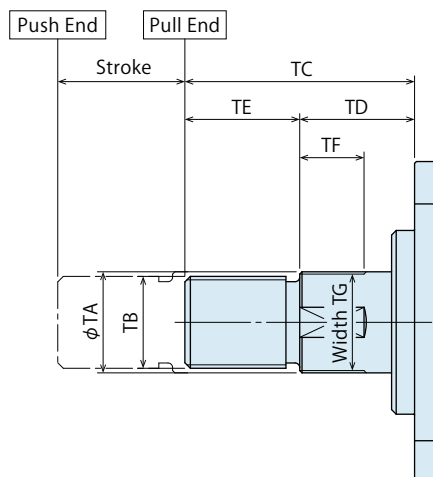

External Dimension List : Option S1 with Backward End Confirmation Switch

● Cylinder Body Part

(mm)

Model No.	PCD0400-S1	PCD0630-S1	PCD0800-S1
B	40 $f7$ $\begin{matrix} -0.025 \\ -0.050 \end{matrix}$	52 $f7$ $\begin{matrix} -0.030 \\ -0.060 \end{matrix}$	62 $f7$ $\begin{matrix} -0.030 \\ -0.060 \end{matrix}$
D	43	48	53
E	14.5	17	18
F	24.5	25	29
G	Rc1/4	Rc1/4	Rc3/8
H	10	12	15
K	7.5	5	4
L	9	14	16
M	70	94	114
N	45	67	83
P	84	122	148
Cylinder Tightening Bolt	M8×1.25	M12×1.75	M14×2

● Rod Shape A : Female Thread

(mm)

Model No.	PCD0400-A-S1	PCD0630-A-S1	PCD0800-A-S1
AA	22	35.5	45
AB	14	17	22
AC	20	25	30
AD	21	32	41
AE (Nominal×Pitch×Depth)	M16×2×20	M27×3×35	M30×3.5×35

● Rod Shape C : Coupling

(mm)

Model No.	PCD0400-C-S1	PCD0630-C-S1	PCD0800-C-S1
CA	22	35.5	45
CB	16	25	31
CC	60	70	75
CD	35	40	45
CE	12.5	15	15
CF	12.5	15	15
Cr	R1	R1.5	R2

● Rod Shape T : Male Thread

(mm)

Model No.	PCD0400-T-S1	PCD0630-T-S1	PCD0800-T-S1
TA	22	35.5	45
TB	M20×1.5	M30×1.5	M40×1.5
TC	50	66	80
TD	25	30	35
TE	25	36	45
TF	14	17	22
TG	21	32	41

● Switch Specifications

Proximity Switch Model No.	BES516-300-S205-D-PU03 (Made by BALLUFF)
Electrical Rating	DC10 ~ 30V 200mA
Cable Specification	PUR Cable 3 Cores 3m
Operating Temperature	0 ~ 80°C
Protection Level	IP68
Switching Output	PNP (N.O.)

※. Refer to maker's specifications for the detail of the switch.

External Dimensions : Option S2 with Magnetostrictive Sensor

※ This drawing shows the pull end state of PCD-S2.

Rod Shape A : Female Thread

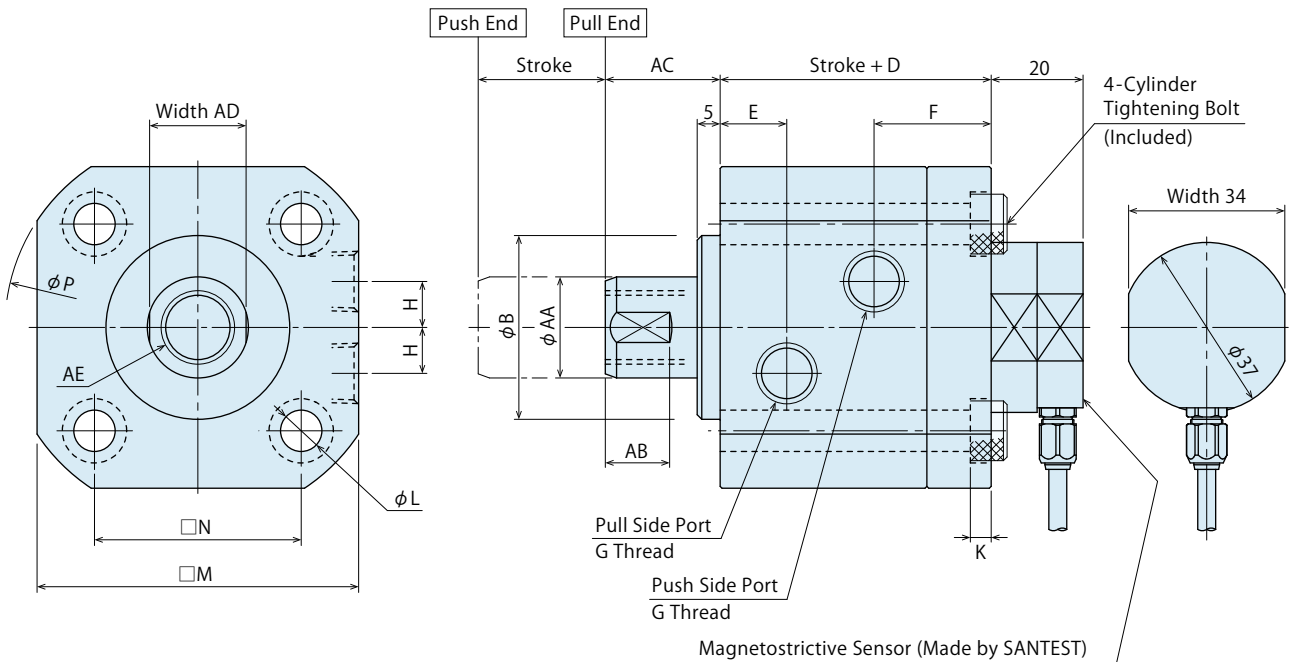

Magnetostrictive Sensor (Made by SANTEST)
 GYGS-□□-16/20-N8-CJ-G3LF-00
 Controller : GYHC-GS-□□-Z16-CJ-V1/5/N-24S
 ※. Refer to maker's specifications for the details of the sensor.

Rod Shape C : Coupling

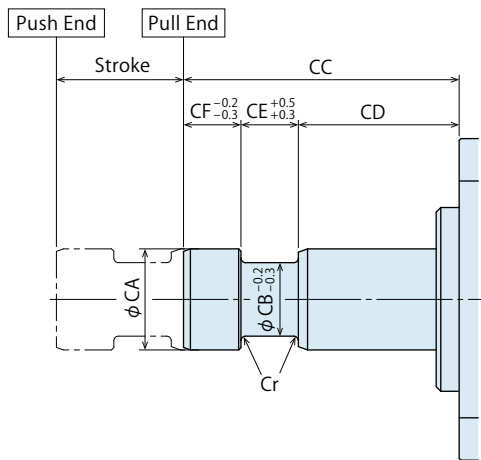

Rod Shape T : Male Thread

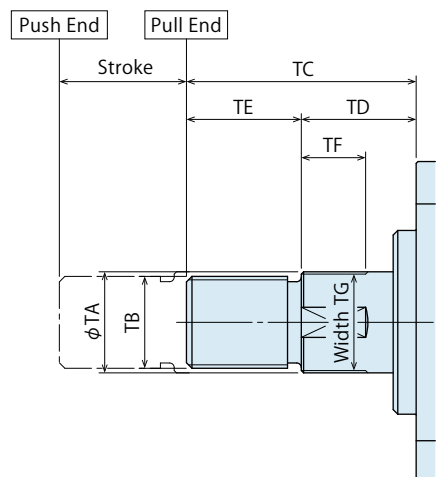

External Dimension List : Option S2 with Magnetostrictive Sensor

● Cylinder Body Part

(mm)

Model No.	PCD0400-S2	PCD0630-S2	PCD0800-S2
B	40 $f7$ $_{-0.025}^{-0.050}$	52 $f7$ $_{-0.030}^{-0.060}$	62 $f7$ $_{-0.030}^{-0.060}$
D	44	52	58
E	14.5	17	18
F	25.5	29	34
G	Rc1/4	Rc1/4	Rc3/8
H	10	12	15
K	8	9	9
L	9	14	16
M	70	94	114
N	45	67	83
P	84	122	148
Cylinder Tightening Bolt	M8×1.25	M12×1.75	M14×2

● Rod Shape A : Female Thread

(mm)

Model No.	PCD0400-A-S2	PCD0630-A-S2	PCD0800-A-S2
AA	22	35.5	45
AB	14	17	22
AC	25	40	35
AD	21	32	41
AE (Nominal×Pitch×Depth)	M16×2×20	M27×3×35	M30×3.5×35

● Rod Shape C : Coupling

(mm)

Model No.	PCD0400-C-S2	PCD0630-C-S2	PCD0800-C-S2
CA	22	35.5	45
CB	16	25	31
CC	60	70	75
CD	35	40	45
CE	12.5	15	15
CF	12.5	15	15
Cr	R1	R1.5	R2

● Rod Shape T : Male Thread

(mm)

Model No.	PCD0400-T-S2	PCD0630-T-S2	PCD0800-T-S2
TA	22	35.5	45
TB	M20×1.5	M30×1.5	M40×1.5
TC	50	66	80
TD	25	30	35
TE	25	36	45
TF	14	17	22
TG	21	32	41

High-Power
Core Push CylinderHigh-Speed
Core Pull CylinderHigh-Speed
Core Pull Cylinder
Compact ModelHigh-Power
Core Pull Cylinder

Flat Cylinder

Notes for Handling Magnetostrictive Sensor

Outline Figure

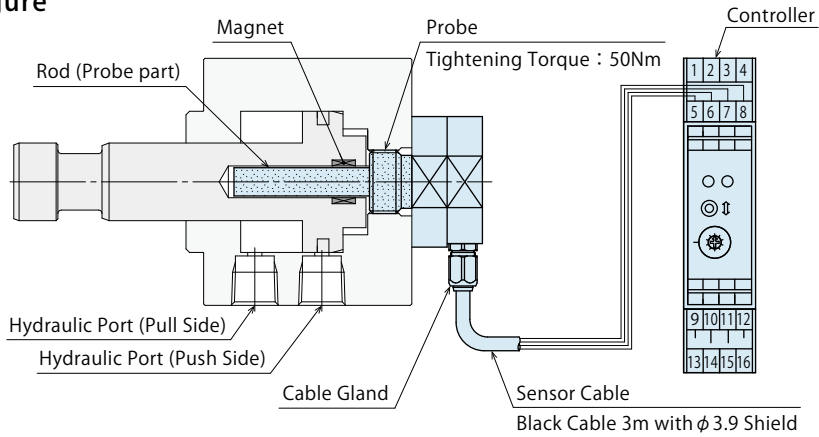

Specifications

Probe

Probe Model No.	GYGS-□□-16/20-N8-CJ-G3LF-00 (Made by SANTEST)
Repeatability	±0.15%FS or less
Temperature Drift	±0.06%FS/°C
Output	1 ~ 5 V Voltage Output (Load Current Max.5mA, Load Resistance 500Ω)
Sampling Frequency	About 1kHz
Withstanding Pressure	35MPa (Probe Rod)
Operating Temperature	0 ~ 80°C
Vibration Resistance	6G (or 40Hz 2mmPP)
Shock Resistance	50G (2msec)
Protection Grade	IP67

Controller

Controller Model No.	GYHC-GS-□□-Z16-CJ-V1/5/N-24S (Made by SANTEST)
Power Supply	±24VDC±5% (150mA or less)
Operating Temperature	0°C ~ 65°C
Storage Temperature	-20°C ~ 85°C
Temperature Drift	±3 μm/°C

Magnetostrictive Sensor Connection Diagram

Terminal No.	Terminal Name	Function (or Cable Color)
1	-	-
2	-	-
3	-	-
4	-	-
5	R	Probe Red Cable
6	W	Probe White Cable
7	B	Probe Black Cable
8	S	Probe Shield Cable
9	OUT1	Analog Position Output
10	COM	COM
11	-	-
12	-	-
13	24V	Power 24VDC
14	0V	Power 0V
15	-	-
16	-	-

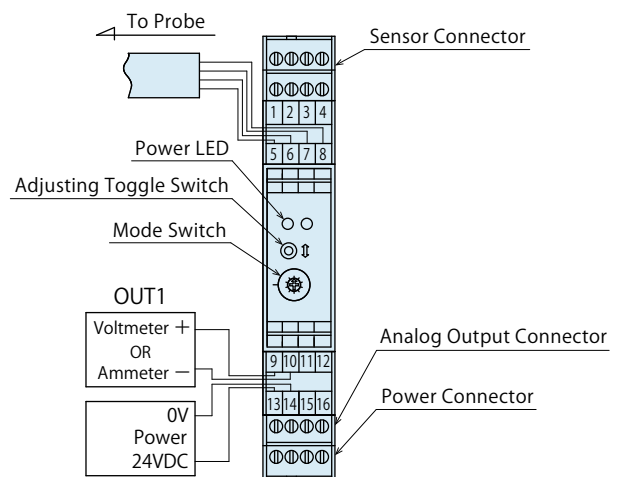

How to Connect Lead to Connector

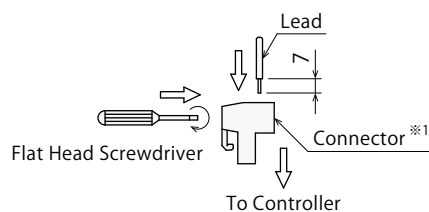

Note :

※1. Connector is installed to the controller.

Connecting Lead Diam.	0.2mm ² ~ 2.5mm ²
Screw Tightening Torque	0.5Nm (Max. 1.0Nm)
Driver Width	3mm or less
Connector	MSTBT2.5/4-ST (Made by PHOENIX CONTACT)

1. Please wire with care. Wiring error can cause a malfunction.

● How to Change the Direction of Cable Outlet

The head with cable gland turns $\pm 180^\circ$ by loosening the three set screws on the hexagonal flange.
After deciding the cable outlet position, tighten the set screws (recommended torque : 0.3Nm).
Set screws come with screw locking glue applied.

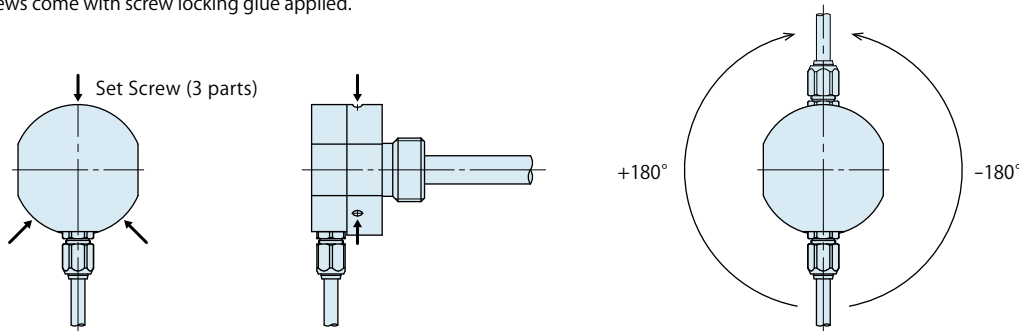

● How to Adjust Zero-Scale and Full-Scale Output

Adjustment of Zero-Scale Output

- ① Move the piston to the backward end.
- ② Set the "Mode Switch" to No. 1.
- ③ Tilt the adjusting toggle switch up and down to set the output 1V.
Keeping the toggle switch up or down increases adjusting amount.
- ④ After adjusting is completed, return the "Mode Switch" to No. 0.

Adjustment of Full-Scale Output

- ① Move the piston to the forward end.
- ② Set the "Mode Switch" to No.2.
- ③ Tilt the adjusting toggle switch up and down to set the output 5V.
Keeping the toggle switch up or down increases adjusting amount.
- ④ After adjusting is completed, return the "Mode Switch" to No. 0.

● Notes for Handling

Probe Part

- Do not bend or damage the rod.
- The cable gland part cannot be removed. Removing it forcibly will break the probe part.

Sensor Cable Part

- Do not strongly pull or damage the cable.
- Parts of the cable gland are designed to be waterproof.
However, we recommend a shielding plate for waterproofing purpose especially in the environment where cable is exposed to water and oil.
- To avoid pulling the cable, make sure to fix the cable to a nearby pillar, existing machine or building.

● Notes for Wiring

- Make sure to shut off the power before wiring.
- Make sure to confirm that terminal and connector are securely tightened before turning on the power.
- This sensor is designed to process extremely small signals.
Please be careful with the following points in order to exert full ability of the sensor.
Make wiring length as short as possible.
Separate the power line, electric power line and sensor cables.
Install a surge-absorption device to coil products such as relay, electromagnetic switch and others.
- Before connecting cables, make sure that there is no dirt, water or oil adhered on the cable connecting part and the terminal part of the controller.
- When extending cables, be careful of wiring. Wiring error can cause a malfunction.

● Accessories

● P Joint

Model No.

PCZ 100 0 - P
 1 Size
 2 Design No.

PCMZ 40 0 - P
 1 Size
 2 Design No.

External Dimensions

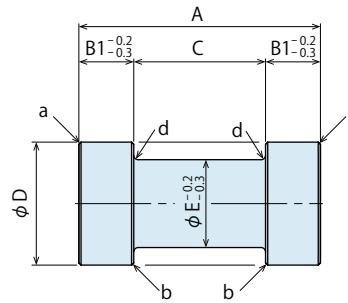

External Dimension List

Model No.	PCMZ400-P	PCZ0400-P	PCZ0630-P	PCZ0800-P	PCZ1000-P	PCZ1250-P	PCZ1600-P	PCZ2000-P	PCZ2500-P
Corresponding Model No.	PCE0401-C PCM0400-C	PCM0500-C PCD0400-C	PCA0633-C PCB0633-C PCC0633-C PCE0631-C	PCA0803-C PCB0803-C PCC0803-C PCE0801-C PCD0630-C	PCA1003-C PCB1003-C PCC1003-C PCE1001-C PCD0800-C	PCA1253-C PCB1253-C PCC1253-C PCE1251-C	PCA1603-C PCB1603-C PCC1603-C	PCA2003-C PCB2003-C	PCA2503-C PCB2503-C
A	55	55	55	65.5	65.5	85.5	105.5	125.5	145.5
B1	12.5	12.5	12.5	15	15	20	25	30	35
C	30	30	30	35.5	35.5	45.5	55.5	65.5	75.5
D (Rod Diameter)	18 $f7_{-0.034}^{-0.016}$	22 $f7_{-0.041}^{-0.020}$	28 $f7_{-0.041}^{-0.020}$	35.5 $f7_{-0.050}^{-0.025}$	45 $f7_{-0.050}^{-0.025}$	56 $f7_{-0.060}^{-0.030}$	70 $f7_{-0.060}^{-0.030}$	90 $f7_{-0.071}^{-0.036}$	110 $f7_{-0.071}^{-0.036}$
E	13	16	20	25	31	38	49	60	78
a	C0.5	C0.5	C0.5	C1	C1.5	C1.5	C2	C2	C2
b	C0.5	C0.5	C0.5	C1	C1	C1	C1	C1	C2
d	R1	R1	R1	R1.5	R2	R2	R3.5	R5	R5

(mm)

- High-Power Core Push Cylinder
- High-Speed Core Pull Cylinder
- High-Speed Core Pull Cylinder Compact Model
- High-Power Core Pull Cylinder
- Flat Cylinder

● S Joint

Model No.

PCZ 100 0 - S

1 Size

2 Design No.

PCMZ 40 0 - S

1 Size

2 Design No.

External Dimensions

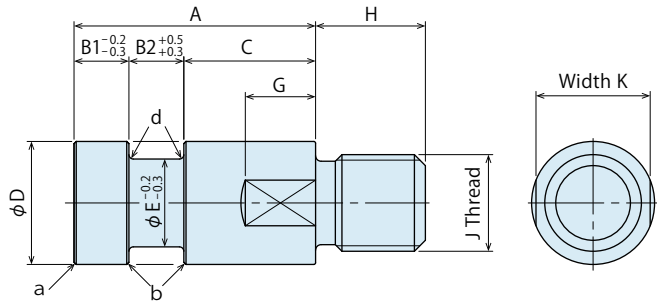

External Dimension List

(mm)

Model No.	PCMZ400-S	PCZ0400-S	PCZ0630-S	PCZ0800-S	PCZ1000-S	PCZ1250-S	PCZ1600-S	PCZ2000-S	PCZ2500-S
Corresponding Model No.	PCE0401-C PCM0400-C	PCM0500-C PCD0400-C	PCA0633-C PCB0633-C PCC0633-C PCE0631-C	PCA0803-C PCB0803-C PCC0803-C PCE0801-C PCD0630-C	PCA1003-C PCB1003-C PCC1003-C PCE1001-C PCD0800-C	PCA1253-C PCB1253-C PCC1253-C PCE1251-C	PCA1603-C PCB1603-C PCC1603-C	PCA2003-C PCB2003-C	PCA2503-C PCB2503-C
A	55	55	55	65.5	65.5	85.5	105.5	125.5	145.5
B1	12.5	12.5	12.5	15	15	20	25	30	35
B2	12.5	12.5	12.5	15	15	20	25	30	35
C	30	30	30	35.5	35.5	45.5	55.5	65.5	75.5
D (Rod Diameter)	18 $f7 \begin{smallmatrix} -0.016 \\ -0.034 \end{smallmatrix}$	22 $f7 \begin{smallmatrix} -0.020 \\ -0.041 \end{smallmatrix}$	28 $f7 \begin{smallmatrix} -0.020 \\ -0.041 \end{smallmatrix}$	35.5 $f7 \begin{smallmatrix} -0.025 \\ -0.050 \end{smallmatrix}$	45 $f7 \begin{smallmatrix} -0.025 \\ -0.050 \end{smallmatrix}$	56 $f7 \begin{smallmatrix} -0.030 \\ -0.060 \end{smallmatrix}$	70 $f7 \begin{smallmatrix} -0.030 \\ -0.060 \end{smallmatrix}$	90 $f7 \begin{smallmatrix} -0.036 \\ -0.071 \end{smallmatrix}$	110 $f7 \begin{smallmatrix} -0.036 \\ -0.071 \end{smallmatrix}$
E	13	16	20	25	31	38	49	60	78
G	12	14	16	17	22	23	27	20	20
H	14	22	25	25	30	40	50	60	80
J	M12×1.75	M20×2.5	M22×2.5	M24×3	M30×3.5	M39×4	M48×5	M60×5.5	M80×2
K	17	21	26	32	41	54	67	86	105
a	C0.5	C0.5	C0.5	C1	C1.5	C1.5	C2	C2	C2
b	C0.5	C0.5	C0.5	C1	C1	C1	C1	C1	C2
d	R1	R1	R1	R1.5	R2	R2	R3.5	R5	R5

● Accessories

● Coupling

Model No.

External Dimensions

PCZ 100 0 - C

2 Design No.

1 Size

PCMZ 40 0 - C

2 Design No.

1 Size

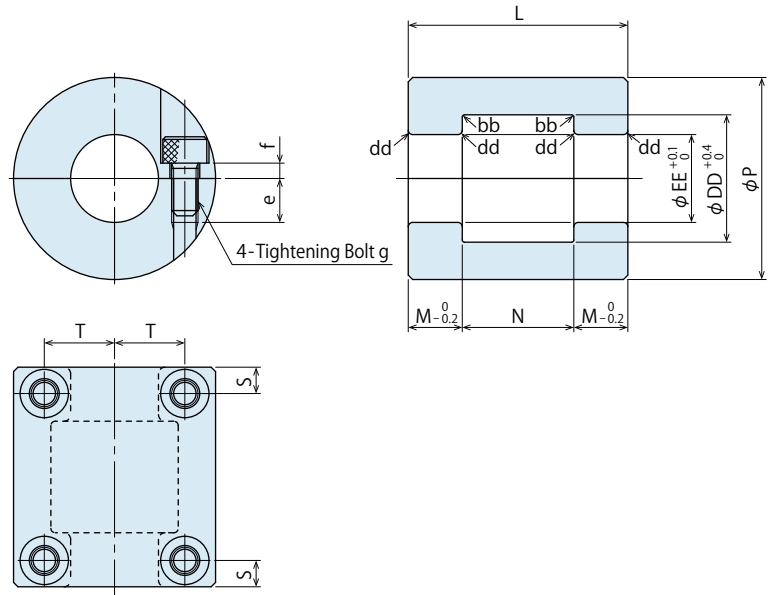

External Dimension List

Model No.	PCMZ400-C	PCZ0400-C	PCZ0630-C	PCZ0800-C	PCZ1000-C	PCZ1250-C	PCZ1600-C	PCZ2000-C	PCZ2500-C
Corresponding Model No.	PCE0401-C PCM0400-C	PCM0500-C PCD0400-C	PCA0633-C PCB0633-C PCC0633-C PCE0631-C	PCA0803-C PCB0803-C PCC0803-C PCE0801-C PCD0630-C	PCA1003-C PCB1003-C PCC1003-C PCE1001-C PCD0800-C	PCA1253-C PCB1253-C PCC1253-C PCE1251-C	PCA1603-C PCB1603-C PCC1603-C	PCA2003-C PCB2003-C	PCA2503-C PCB2503-C
L	50	50	50	60	60	80	100	120	140
M	12.3	12.3	12.3	14.8	14.8	19.8	24.8	29.7	34.7
N	25.4	25.4	25.4	30.4	30.4	40.4	50.4	60.6	70.6
P	35	42	46	54	62	75	94	118	144
DD	18.3	22.3	29	36.5	46	58	72	92.5	112.5
EE	13	16	20	25.5	32	39	50	62	80
bb	R0.5	R0.5	R0.5	R1	R1	R1	R1	R1	R1
dd	R1	R1	R1	R1.5	R2	R2	R3.5	R5	R5
S	6	6	6	7	7	9	12	15	14
T	11.5	14	16	19	22	27	35	45	55
e	9	10	10	10.5	10	13	14.5	14.5	21
f	3.5	3	3.5	6	8	12.5	11	16	12
Tightening Bolt g	M5×0.8×12	M6×1×12	M6×1×12	M6×1×16	M6×1×20	M6×1×25	M8×1.25×25	M8×1.25×30	M14×2×30

(mm)

High-Power
Core Push Cylinder

High-Speed
Core Pull Cylinder

High-Speed
Core Pull Cylinder
Compact Model

High-Power
Core Pull Cylinder

Flat Cylinder

Cautions

Notes for Design

- 1) Check Specifications
 - Please use each product according to the specifications. Applying excessive load on the cylinder leads to deformation, galling and oil leak.
 - Since this product is used under various conditions, the suitability to the system should be decided by a hydraulic/pneumatic system designer or a person who decides specifications after conducting an analysis and a test as needed.
- 2) Notes for Circuit Design
 - Please read "Notes on Hydraulic Cylinder Speed Control Unit" for proper hydraulic circuit design. Improper circuit design may lead to malfunctions and damages. (Refer to P.71)
 - Ensure there is no possibility of supplying hydraulic pressure to the push side and the pull side simultaneously.
- 3) Make sure no force is applied to the rod except from the axial direction.
 - Applying offset load on the rod leads to deformation, galling and oil leak.
- 4) Please use with extra stroke taken into consideration.
- 5) Keep clear condition at vent hole. (PCA/PCC Only)
 - Keep clear condition at vent hole for smooth cylinder operation. Make sure not to block the vent hole when designing and mounting molds. Prevent invasion of liquid from the vent hole.
- 6) For using option : with Auto Circulation (PCD-J)
 - This option automatically circulates (leaks inside) on the piston pull end. By leaking oil inside, it is able to release air in the cylinder automatically. Also, it cools oil since the oil remained in the cylinder is replaced with the oil in the tank. Oil is leaked inside when the piston moves backward, so pressure in the circuit might be largely decreased depending on the supply flow rate.

Installation Notes

- 1) Check the Usable Fluid
 - Please use the appropriate fluid by referring to the Hydraulic Fluid List.
- 2) Preparation before Piping
 - Pipeline, piping connector and fixture circuits should be cleaned by thorough flushing.
 - Dust and cutting chips in the circuit may lead to oil leak and malfunction.
 - Our products, except some valves, are not equipped with protective function to prevent dust and cutting chips going into the hydraulic system and pipeline.
- 3) Applying Sealing Tape
 - Wrap with tape 1 to 2 times following the screwing direction.
 - Pieces of the sealing tape can lead to oil leak and malfunction.
 - In order to prevent contaminants from going into the product during piping, it should be carefully cleaned.

4) Cylinder Installation

- Use four hexagonal socket bolts and tighten them with the torque shown in the list below. Installation failure leads to oil leak, deformation and damage of the cylinder.

Model No.	Mounting Bolt Size	Strength	Tightening Torque (N·m)
PCA/PCB/PCC0633	M16×2	12.9	200
PCA/PCB/PCC0803	M16×2	12.9	200
PCA/PCB/PCC1003	M20×2.5	12.9	400
PCA/PCB/PCC1253	M24×3	10.9	630
PCA/PCB/PCC1603	M30×3.5	10.9	1250
PCA/PCB2003	M36×4	10.9	1600
PCA/PCB2503	M36×4	10.9	1600
PCE0401	M12×1.75	12.9	80
PCE0631	M16×2	12.9	200
PCE0801	M16×2	12.9	200
PCE1001	M20×2.5	12.9	400
PCE1251	M24×3	10.9	630
PCD0400	M12×1.75	12.9	80
PCD0500	M12×1.75	12.9	80
PCD0400	M8×1.25	12.9	25
PCD0630	M12×1.75	12.9	80
PCD0800	M14×2	12.9	125

- The bottom cover of PCD cylinder is just temporarily tightened, so pressure supply to the product without mounted on a mold is extremely dangerous causing damages. It must be mounted on the mold and tightened with four mounting bolts before pressure supply. Also, make sure to inspect that the product is securely tightened on a regular basis.
- 5) Attachment Installation
- For using rod shape **T** : Male Thread, when mounting and removing the attachment, hold the piston with a spanner or adjustable wrench at edge.
 - In order to stabilize tightening axial force, apply molybdenum grease on the thread part and seating surface. (Grease is applied at shipment.) And after : When tightening, it is recommended to apply grease (lithium based) available in the market. (Only for PCA/PCB/PCC/PCE)
 - Installation failure leads to deformation and damage of the clamp, so make sure that the product is securely tightened on a regular basis.

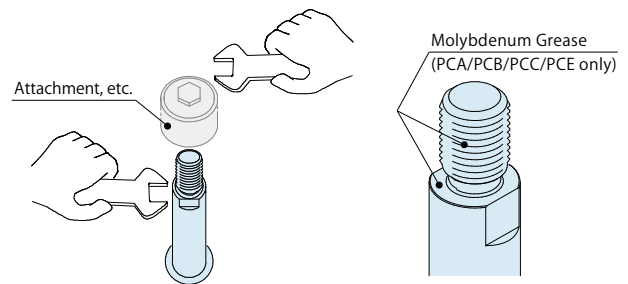

Rod Shape	Model No.	Head Thread Size	Tightening Torque (N·m)	
T Male Thread	PCA	PCA/PCC0633-T	M24×1.5 350	
	PCC	PCA/PCC0803-T	M30×1.5 730	
		PCA/PCC1003-T	M40×1.5 1390	
	PCB		PCB0633-T	M24×1.5 200
			PCB0803-T	M30×1.5 400
			PCB1003-T	M40×1.5 800
			PCB1253-T	M50×1.5 1400
			PCE0401-T	M16×1.5 120
	PCE		PCE0631-T	M24×1.5 200
			PCE0801-T	M30×1.5 400
			PCE1001-T	M40×1.5 800
			PCE1251-T	M50×1.5 1400
		PCD		PCD0400-T
			PCD0630-T	M30×1.5 400
			PCD0800-T	M40×1.5 800
A Female Thread	PCD		PCD0400-A	M16×2 100
		PCD0630-A	M27×3 400	
		PCD0800-A	M30×3.5 630	

6) Trial Operation Method

- There is a lot of air in the circuit just after installation.

If high pressure with large flow rate is supplied under such condition, action time will be extremely fast leading to severe damage on a cylinder. Make sure to perform running-in operation with low pressure with small flow rate and release the air in the circuit.

7) Operating Speed Adjustment

- Excessively fast operating speed of the cylinder may lead to wear-out or damage of internal components.
- Install a flow control valve and gradually control the flow rate from the low-speed side (small flow) to the designated speed. Controlling from the high-speed side (large flow) causes excessive surge pressure or overload to the cylinder leading to damage of a product and/or device.
- When controlling the speed with a flow control valve, make sure there is no excessively high pressure in the hydraulic circuit.
- Speed control may not be conducted if there is excessive air in the hydraulic circuit.
- The viscosity of fluid will decrease when its temperature increases. This will slow the operating speed of the cylinder. Adjust the speed under the proper temperature condition.
- When using option : with Pull-End Cushion (PCA/PCB/PCC/PCE-H)
 - ① Adjust cushioning only after air bleeding.
 - ② For cushion speed adjustment, start from the low piston speed 50mm/sec or less, and increase the speed gradually. (Adjusting Screw; Clockwise = Large Cushioning, Counter-Clockwise = Small Cushioning)
 - ③ After speed adjustment is completed, fix the adjusting screw and tighten the M6×1 Lock Nut.

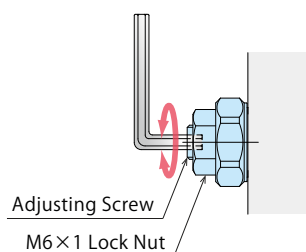

8) Air Bleeding in the Hydraulic Circuit

- If the hydraulic circuit has excessive air, the action time may become very long. If air enters the circuit after connecting the hydraulic port or under the condition of no oil in a tank of a pump, please perform the following steps.

- ① Reduce hydraulic pressure to less than 2MPa.
- ② Loosen the cap nut of pipe fitting closest to the cylinder by one full turn.
- ③ Wiggle the pipeline to loosen the outlet of pipe fitting. Hydraulic fluid mixed with air comes out.

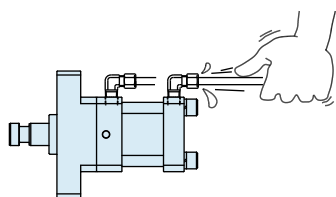

- ④ Tighten the cap nut after air bleeding.

- ⑤ It is more effective to release air at the highest point inside the circuit or at the end of the circuit. (Set an air bleeding valve at the highest point inside the circuit.)

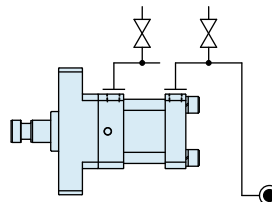

- When using option : with Air Bleed Valve (PCA/PCB/PCC/PCE-X)

- ① It is dangerous to release air during operation under high pressure. It must be done under lower pressure. (2MPa or less)
- ② When releasing air, do not loosen the plug too much. (Do not loosen more than two turns from fully closed state.)
- ③ Oil might be suddenly spouted during air bleeding. Do not release air toward fire or people.
- ④ After air bleeding completed, tighten the plug to stop the oil. After that, securely tighten the M6×1 Lock Nut.

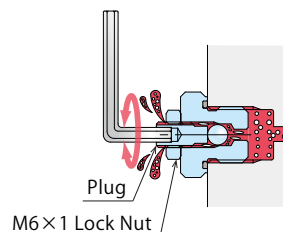

- When Using Air Bleeding Plug (PCD)

Air bleeding on the push side circuit is possible by loosening the plug on the cylinder bottom.

- ① It is dangerous to release air during operation under high pressure. It must be done under lower pressure. (2MPa or less)
- ② When releasing air, do not loosen the plug too much. (Should be loosened about 90° as a guide.)
- ③ Oil might be suddenly spouted during air bleeding. Do not release air toward fire or people.
- ④ After air bleeding completed, tighten the plug to stop the oil.

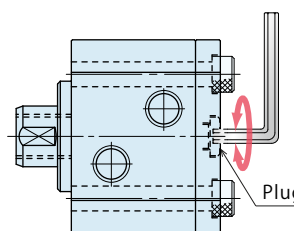

9) Checking Looseness and Retightening

- At the beginning of installation, bolts may be tightened lightly. Check torque and re-tighten as required.

Cautions

Notes on Hydraulic Cylinder Speed Control Circuit

Please pay attention to the cautions below. Design the hydraulic circuit for controlling the action speed of hydraulic cylinder.
 Improper circuit design may lead to malfunctions and damages.
 Please review the circuit design in advance.

1) Speed Control Circuit

- For speed control it should have meter-in circuits for both the push and pull sides. In the case of meter-out circuit, the inner circuit pressure may increase during the cylinder action depending on fluid volume.

【Meter-in Circuit】

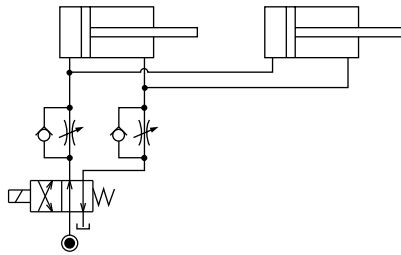

Hydraulic Fluid List

- Please use appropriate fluid referring to the fluid lists below.
- Appropriate fluid differs depending on materials of cylinder packing. Check the appropriate fluid on specifications.

General Hydraulic Oil ISO Viscosity Grade ISO-VG-32

Maker	Anti-Wear Hydraulic Oil	Multi-Purpose Hydraulic Oil
Showa Shell Sekiyu	Tellus S2 M 32	Morlina S2 B 32
Idemitsu Kosan	Daphne Hydraulic Fluid 32	Daphne Super Multi Oil 32
JX Nippon Oil & Energy	Super Hyrando 32	Super Mulpus DX 32
Cosmo Oil	Cosmo Hydro AW32	Cosmo New Mighty Super 32
ExxonMobil	Mobil DTE 24	Mobil DTE 24 Light
Matsumura Oil	Hydol AW-32	-
Castrol	Hyspin AWS 32	-

Water · Glycol ISO Viscosity Grade ISO-VG-32

Maker	Water · Glycol
JX Nippon Oil & Energy	Hyrando FRZ32
Cosmo Oil	Cosmo Fluid HQ46
Matsumura Oil	Hydol HAW32

Silicon Oil ISO Viscosity Grade ISO-VG-68

Maker	Silicon Oil
Shin-Etsu Chemical	KF-50-100cs

Fatty Acid Ester

Maker	Fatty Acid Ester	ISO Viscosity Grade
Showa Shell Sekiyu	Shell Iruis Fluid DU56	(ISO-VG-56)
Idemitsu Kosan	Firgist ES	ISO-VG-68
JX Nippon Oil & Energy	Hyrando S556	(ISO-VG-56)
Cosmo Oil	Cosmo Fluid E46	ISO-VG-46
Nippon Quaker Chemical	QUINTOLUBRIC® 822-200	ISO-VG-46

Note : Please contact manufacturers when customers require products in the list above.

Notes on Handling

- 1) It should be operated by qualified personnel.
- The diecast machines and the products should be operated and maintained by qualified personnel.
- 2) Do not operate or remove the product unless the safety protocols are ensured.
 - ① The machine and equipment can only be inspected or prepared when it is confirmed that the safety devices are in place.
 - ② Before the product is removed, make sure that the above-mentioned safety devices are in place. Shut off the pressure and power source, and make sure no pressure exists in the air and hydraulic circuits.
 - ③ After stopping the machine, do not remove until the product cools down.
 - ④ Make sure there is no abnormality in the bolts and respective parts before restarting the machine or equipment.
- 3) Do not touch cylinders while they are working. Otherwise, your hands may be injured.

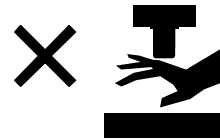

- 4) Do not disassemble or modify.
 - If the equipment is taken apart or modified, the warranty will be voided even within the warranty period.
- 5) Please do not pour water / oil over the product.
 - It may lead to malfunction or deterioration of the product and cause an accident.

● Maintenance and Inspection

- 1) Removal of the Product and Shut-off of Pressure Source
 - Before the product is removed, make sure that safety devices and preventive devices are in place. Shut off the pressure and power source, and make sure no pressure exists in the hydraulic and air circuits.
 - Make sure there is no abnormality in the bolts and respective parts before restarting.
- 2) Regularly clean the area around the cylinder.
 - If it is used when the surface is contaminated with dirt, it may lead to packing seal damage, malfunction and oil leak.

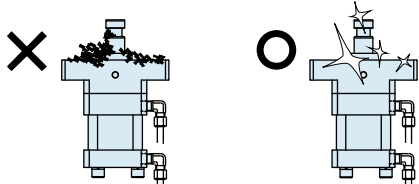

- 3) If disconnecting by couplers, air bleeding should be carried out on a regular basis to avoid air mixed in the circuit.
- 4) Regularly tighten bolts and pipe line and mounting bolts to ensure proper use.
- 5) Make sure the hydraulic fluid has not deteriorated.
- 6) Make sure there is smooth action and no abnormal noise.
 - Especially when it is restarted after being left unused for a long period, make sure it can be operated properly.
- 7) The products should be stored in the cool and dark place without direct sunshine or moisture.
- 8) Please contact us for overhaul and repair.

● Warranty

- 1) Warranty Period
 - The product warranty period is 18 months from shipment from our factory or 12 months from initial use, whichever is earlier.
- 2) Warranty Scope
 - If the product is damaged or malfunctions during the warranty period due to faulty design, materials or workmanship, we will replace or repair the defective part at our expense. Defects or failures caused by the following are not covered.
 - ① If the stipulated maintenance and inspection are not carried out.
 - ② If the product is used while it is not suitable for use based on the operator's judgment, resulting in defect.
 - ③ If it is used or handled inappropriately by the operator. (Including damage caused by the misconduct of the third party.)
 - ④ If the defect is caused by reasons other than our responsibility.
 - ⑤ If repair or modifications are carried out by anyone other than Kosmek, or without our approval and confirmation, it will void warranty.
 - ⑥ Other damages caused by natural disasters or calamities not attributable to our company.
 - ⑦ Parts or replacement expenses due to parts consumption and deterioration. (Such as rubber, plastic, seal material and some electric components.)

Damages excluding from direct result of a product defect shall be excluded from the warranty.

KOSMEK Products for Diecast Systems

Application examples with press machine related
KOSMEK products are available on our website.

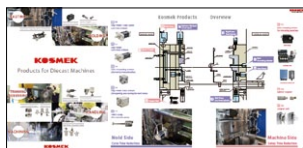

http://www.kosmek.co.jp/php_file/video_index.php?lang=2

KDCS Complete Catalog

For further information of other products,
please order the complete catalog from our website.



Scan the QR code for
Catalog Request and Inquiry

http://www.kosmek.co.jp/php_file/inquiry.php?lang=2



KOSMEK LTD.

<http://www.kosmek.com/>

HEAD OFFICE 1-5, 2-chome, Murotani, Nishi-ku, Kobe-city, Hyogo, Japan 651-2241
TEL.+81-78-991-5162 FAX.+81-78-991-8787

United States of America SUBSIDIARY	KOSMEK (USA) LTD. 650 Springer Drive, Lombard, IL 60148 USA TEL. +1-630-620-7650 FAX. +1-630-620-9015
MEXICO REPRESENTATIVE OFFICE	KOSMEK USA Mexico Office Av. Santa Fe 103, Int. 59, col. Santa Fe Juriquilla, Queretaro, QRO, 76230, Mexico TEL. +52-1-55-3044-9983
EUROPE SUBSIDIARY	KOSMEK EUROPE GmbH Schleppeplatz 2 9020 Klagenfurt am Wörthersee Austria TEL. +43-463-287587 FAX. +43-463-287587-20
CHINA SUBSIDIARY	KOSMEK (CHINA) LTD. Room601, RIVERSIDE PYRAMID No.55, Lane21, Pusan Rd, Pudong Shanghai 200125, China TEL. +86-21-54253000
INDIA BRANCH OFFICE	KOSMEK LTD. - INDIA 4A/Old No:649, Ground Floor, 4th D cross, MM Layout, Kavalbyrasandra, RT Nagar, Bangalore -560032 India TEL.+91-9880561695
THAILAND REPRESENTATIVE OFFICE	KOSMEK Thailand Representation Office 67 Soi 58, RAMA 9 Rd., Phatthanakan, Suanluang, Bangkok 10250, Thailand TEL. +66-2-300-5132 FAX. +66-2-300-5133

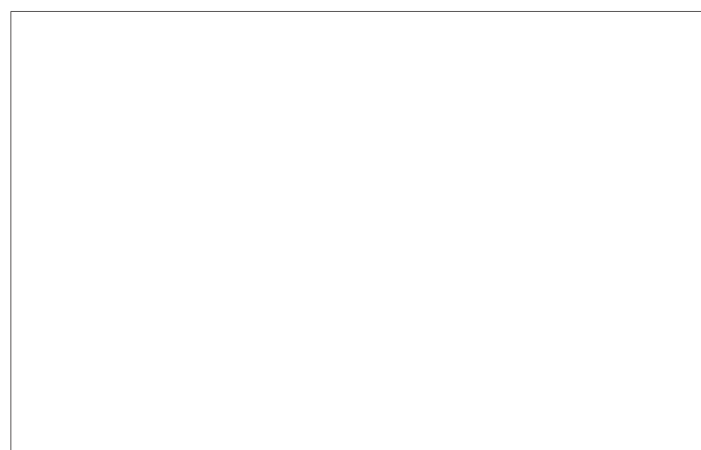

- For Further Information on Unlisted Specifications and Sizes, Please call us.
- Specifications in this Leaflet are Subject to Change without Notice.



JQA-QMA10823
KOSMEK HEAD OFFICE